

The Honda S2000



These specification details do not apply to any particular product which is supplied or offered for sale. The manufacturers reserve the right to vary their specifications, including colours, with or without notice and at such times in such manner as they think fit. Major as well as minor changes may be involved. Every effort, however, is made to ensure the accuracy of the particulars contained in this brochure. This publication shall not constitute in any circumstances whatsoever an offer by the Company to any person. All sales are made by the Distributor or Dealer concerned subject to and with the benefit of the standard Conditions of Sale and Warranty given by the Distributor or Dealer, copies of which may be obtained from him on request. This publicity material applies to the UK only Trade Descriptions Act (1968). Whilst efforts are made to ensure specification accuracy, brochures are prepared and printed several months in advance of distribution and consequently cannot always immediately reflect either changes in specification or in some isolated cases the provision of a particular feature. Customers are always advised to discuss specification details with the supplying Dealer especially if your model selection is dependent upon one of the features advertised.

Honda (UK) - Cars

470 London Road, Slough, Berkshire, SL3 8QY
Honda Contact Centre - Telephone: 0845 200 8000
www.honda.co.uk



Printed on Recycled Paper

A division of Honda Motor Europe Ltd. No. 857969 Registered in England and Wales

Part No: CARM 1069
Issue Date: 07/06





At Honda, belief is everything.

It's the belief that we have the power to change things.

To make the ordinary, extraordinary.

To question the status quo.

To take a boundary and extend it.

We've spent 50 years at the top of international motorsport.

We wanted to celebrate. And decided to create our ultimate roadster.

We handed some of the world's finest engineering minds a blank sheet of paper.

They applied all their experience, passion - and the power of dreams.

And created a sports car worthy of its pedigree.



Exterior Design	5
Interior Design	11
Driving Dynamics	19
Safety	27
Details	33
Exterior Details	35
Interior Details	37
Model Grades	39
Options	41
Specification	45
Model Colours	47
Finance	49
Aftercare	51
Environment	53
Innovation	55
Range	57



?Do you look at the surface or what lies beneath

We look at both. It is a desire to take our passion for racing and create the ultimate in performance engineering. It's our history that's led us to look at things this way. From the Honda Sports S360 and S500, first built by our founder, Soichiro Honda,

right through to the S600, the S800 and the first ever all-aluminium sports car, the Honda NSX. The Honda S2000 has been a natural evolution. A 50th birthday gift to ourselves. It isn't a car built from the inside out or indeed the outside in. This is a car designed as a whole. Every component coming together as one. We don't believe in limitations. Here is the evidence. The Honda S2000. Look deeply.





?Ever noticed how a second look tends to be more revealing

It's easy to overlook the finer details. But take a closer look at the Honda S2000. Let your eyes absorb every inch of the car from front to back. Start with the triple beam headlights. Then follow the aerodynamic lines to the rear. Your eyes leading naturally to the stylish high-mounted brake light and dual chrome oval shaped exhausts.

And take a glance at the new 17" alloy wheels. Their stylish design doesn't just look good, but offers superb grip and stability. Yet for all this detailed thought and relentless logic, the Honda S2000 still has the soul, the sheer magic, that is the essence of a true sports car. You'll just want to keep looking.



?When did you last enjoy making a decision

Hardtop or soft-top? Picture a summer's day, a warm breeze, a coastal road. One efficient flick of a switch, and the soft-top is down giving you an exhilarating drive. Or what about the practicality of a Honda S2000 GT hardtop? Ideal for smooth city driving in all conditions. It's a different style of motoring that offers a more sheltered feel with the addition of greater security and excellent rear visibility. The hardtop can be removed when not required to reveal the soft-top underneath.





?Ever noticed how a little extra thought makes all the difference

The Honda S2000's interior is rich in thoughtful design. It's a purely driver focused environment. The first thing you'll notice is that the instruments don't stretch halfway across the dashboard. It's a completely unique space with every control at your fingertips. Then there's the centre console, built with a convenient sliding lid which opens with one, swift touch. Plus there's space for two cups. Simple design, yet so effective. What about the wind deflector? A glass plate positioned between the headrests means that, even with the roof down, you remain comfortable. Not essential, but what a difference.

The cleverly designed compartment between the seats offers a uniquely large storage space. It can even be locked to give you extra peace of mind with the top down. The stereo is concealed discreetly behind a sleek metallic panel. And roll bar speakers fitted to the rear of the headrests now come as standard, so you can maximise your sound quality with the roof down. We don't have to think about these things, but we do. And you'll be glad we did.



?Want to know what empowerment feels like

The Honda S2000 is styled inside to maximise your control. And at the same time to relax you. You feel it the moment you first sit in the newly designed body hugging leather seats. Placed deliberately low, they draw you deep inside, connecting you closely to the lightweight chassis.

You become sensitive to the alloy engine and experience new levels of performance. This is a serious union of driver and sports car.



?Wouldn't life be simpler if everything fell easily to hand

Imagine. No searching, no scrabbling around trying to find things. We think this is how it should be. All you want is to focus on the road, the car, the drive. Each control sits snugly within fingertip distance. The start button and the audio controls are just to the right of the steering wheel for maximum control. The hazard lights and heated window switches are directly next to the gear lever, as is the button that operates the electric hood with its glass rear screen. And the dashboard? A single meticulous display of digital figures. Even the clock is easy-to-glimpse.

The steering wheel is wrapped in luxurious leather. And the brakes are powerful, progressive and fade resistant. Even the pedals are aluminium alloy making them light and sensitive for instant, precise responses. Every detail is designed with you in mind. Designed for you to focus on the drive.





?What happens when you look at things differently

You gain a whole new outlook. That's what our engineers did. To the Honda S2000 they brought all their race experience and not one pre-conception. They questioned how the chassis and suspension could impact performance. Desiring a race car feel in a two-seater roadster meant a move away from the conventional design route. They created a unique suspension system, maximising tyre tread on the road. The result? A convertible that handles with an assuredness you'd usually only expect from a coupé. And all it took was a different perspective.



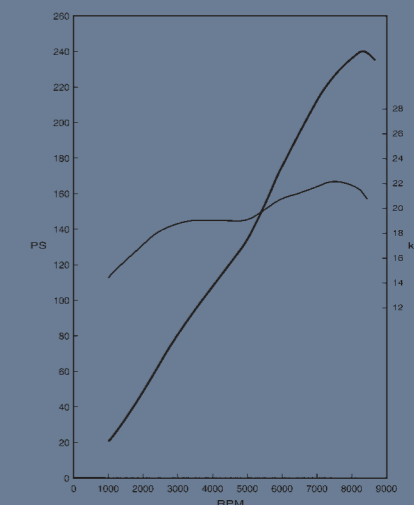

2.0i VTEC performance and torque

?What does it take to make the ordinary, extraordinary

More than you'd expect. Inspired thinking. Radical design. Superior technology. Which explains why the Honda S2000 has won International Engine of the Year*, every year since its launch. Underneath the bonnet is a 2.0i VTEC racebred engine. This sophisticated VTEC system changes the timing and lift of the valves to combine good torque characteristics at low revs with high power at high revs. More intelligent design includes lightweight valve springs and low friction plating.

8,300 rpm. 120PS per naturally aspirated litre. Power unheard of outside the racetrack. But then that's what you'd expect from Tochigi, our research and development centre. And the home of six F1 World Constructors Championships. We never settle for ordinary and neither should you.

*Within the 2.0 litre category



1.8 - 2.0 litre category



1.8 - 2.0 litre category



1.8 - 2.0 litre category



1.8 - 2.0 litre category



Race inspired engine start button

?Are you prepared for the best experiences in life

True driving pleasure lies in precise control. And that's what every element of the Honda S2000 is designed to give you. Grip the lightweight aluminium gearshift. It's wrapped in the same tactile leather as the steering wheel. Start the engine using the race inspired dash mounted start button. It doesn't merely turn over, it comes to life.

The carbon synchroniser connects with each one of the six gears smoothly and effortlessly. The chassis and steering are engineered for maximum stability at high speeds. This is race inspired technology at its finest, which explains why no other roadster delivers a driving experience to match the Honda S2000.



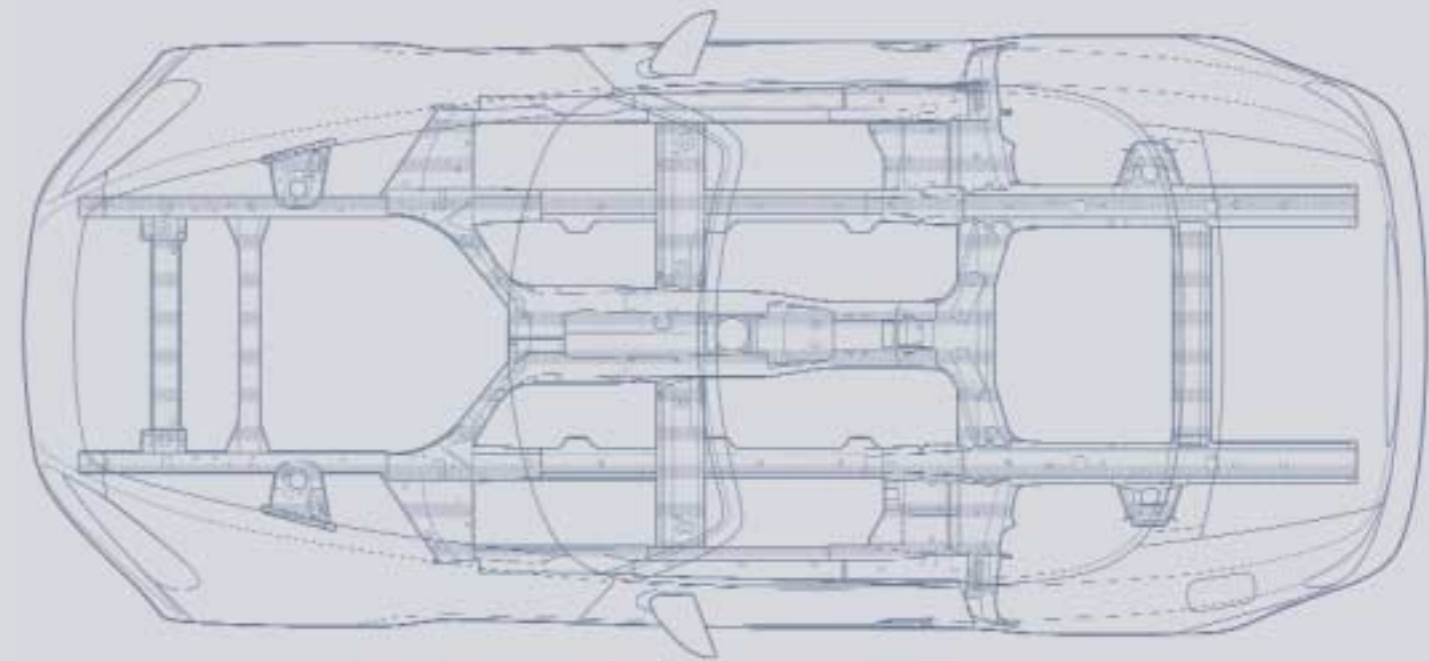

Tochigi, the world's largest crash-testing facility.

By replicating the human body, our unique POLAR II dummy raises pedestrian safety to outstanding levels.

?When do you know you've created perfection

When it can't be bettered. Like our safety measures, we couldn't find a crash test centre that met our standard, so we built one. Tochigi is the largest indoor test-facility in the world. And because we designed it, we know just how vigorous the safety tests are. It's not just passenger safety we test, it's pedestrian safety too. We test impact resilience from every direction and consider every possibility. Because that's how it happens in real life and that's how we maximise your safety.

The Honda S2000 has crumple zones built into its chassis. If an accident happens, sections deform effectively and the crash force distributes into the chassis' centre tunnel. This means increased protection and minimal shock absorption for the occupants. We've included heavy-duty roll bars behind each seat. These reinforced steel loops are fixed directly to the chassis. There's a safety consideration in everything we build. This is safety from inception.



?These days, how easy is it to find peace of mind

With our passion for racing, safety has always been a priority. Driver and passenger airbags are always fitted as standard, as are seatbelt pre-tensioners which tighten more firmly around you in the event of an impact. A seatbelt reminder alerts you to put it on in the first place. There is a lightweight Anti-lock Braking System (ABS). Even the tail-lights are a unique LED design for enhanced brightness and instant reaction. The Honda

S2000's innovative ignition system sets a new code each time you put the key in. The Thatcham approved Category 1 Alarm detects any intrusion, even with the soft-top down, using a sophisticated microwave sensor. With an immobiliser fitted as standard, and an optional Tracker, you can rest assured, your sports car has maximum theft protection. Peace of mind at last.





Impressive new 17" alloy wheels don't just look good but provide optimum grip.



High intensity LED rear brake lights sit with the reversing and driving lights behind impact resistant aerodynamic covers.



The high level, high intensity rear brake light provides additional safety and further improves aerodynamic performance.



To ensure that the HID headlamps maintain their efficiency, powerful headlight washers are fitted as standard.



An eye-catching chrome finish gives the rear exhaust pipes a striking, sporty look.



Triple beam projector headlamps providing powerful HID illumination in low light conditions, sit behind impact resistant, aerodynamic covers.



You'll love to drive the Honda S2000 even when the sun's not shining, so the mirrors have heated elements behind the glass to improve rear visibility.



The flexible radio aerial provides exceptional reception for the Honda S2000's integral radio.



This chrome badge completes the car's high quality exterior look.



Turbulence in the cabin is reduced, thanks to the folding wind deflector, located between the rear headrests.



The foot pedals are aluminium alloy making them light and sensitive for instant, precise responses.



As you climb into the car, you are greeted by a high quality embossed kickplate.



The Honda S2000's integrated in-car entertainment system, not only features a state of the art radio system, but also comes with a CD player.



Roll bar speakers mounted in the headrests maximise sound quality with the roof down.



Race inspired engine start button.



The Honda S2000's instrument panel is an easy to read digital display.



To conceal the radio from prying eyes, it is hidden behind the smart brushed aluminium panel.



For extra convenience, the centre console provides two cup holders plus a storage tray, accessed instantly with a one-touch-open sliding lid.



For occasions when it's impractical to drive with the roof down, you have the option of air conditioning for interior temperature control and optimal visibility, all at your fingertips.



Lockable storage between the two seats encompasses the boot release and has two small bins at the top so you can keep your car tidy.



The Honda S2000 is available in two models, the soft-top convertible 2.0i VTEC Roadster or with a removable hardtop as the 2.0i VTEC GT.



2.0i VTEC Roadster



2.0i VTEC GT





To give the car's exterior a more purposeful stance, there's an option of a deep front spoiler.



To provide the finishing touch to the Honda S2000's smooth lines, aerodynamic panels are available. These further smooth the airflow past the car's impressive rear tyres.



Subtle or sporty. Choose from either the high wing spoiler (pictured) for a more sporty look or a smaller, understated version.

The above are a selection of popular accessories. For a full listing please refer to the price list or your local Honda dealer.

SPECIFICATION

	2.0i VTEC Roadster	2.0i VTEC GT
Engine		
Engine displacement (cc)	1997	1997
Maximum power (PS @ rpm)	240@8300	240@8300
Maximum torque (Nm @ rpm)	208@7500	208@7500
Fuel type	Petrol	Petrol
Recommended fuel rating (RON)	98 recommended	98 recommended
Transmission		
6-speed manual	●	●
Driven wheels	Rear	Rear
Performance		
Maximum speed (mph)	150	150
Acceleration 0-62 mph (secs)	6.2	6.2
Fuel consumption[†]		
Urban	mpg 20.3	20.3
	L/100km 13.9	13.9
Extra urban	mpg 36.2	36.2
	L/100km 7.8	7.8
Combined	mpg 28.2	28.2
	L/100km 10.0	10.0
CO ₂ emission (g/km)	236	236
Weights and towing (kg)*		
Kerb weight	1271	1271
Turning circle - kerb to kerb (m)	10.8	10.8
Wheels and tyres		
Wheels	17" alloy	17" alloy
Tyres (front)	215/45	215/45
Tyres (rear)	245/40	245/40
Spare wheel	Space Saver	Space Saver
Instruments and controls		
Start button	●	●
Digital odometer (trip)	●	●
Automatic headlight height	●	●
Tachometer (rev counter)	●	●
Safety		
Dual front Supplemental Restraint System (SRS) airbags	●	●
High level rear brake light	●	●
Anti-lock Braking System (ABS)	●	●
Headlight washers	●	●
Front ventilated disc brakes	●	●
Rear disc brakes	●	●
Roll over protection	●	●
Anti-roll bars	Front/Rear	Front/Rear
Side impact protection beams	●	●
Seat belt buckle pre-tensioners	●	●

	2.0i VTEC Roadster	2.0i VTEC GT
Security		
Rolling code ECU engine immobiliser	●	●
Boot release in locking centre console	●	●
Tracker system	○	○
Central locking	●	●
Remote keyless entry	●	●
Interior and perimeter alarm system (CAT 1)	●	●
Exterior		
Electrically adjustable and heated door mirrors	●	●
Body coloured bumpers	●	●
Body coloured door mirrors	●	●
Body coloured hard top	○	●
Body coloured door handles	●	●
HID headlights	●	●
Bee sting aerial	●	●
Comfort and convenience		
Electric power assisted steering	●	●
Manual air conditioning with pollen filter	●	●
Front cupholders	●	●
Leather and alloy gear knob	●	●
Leather wrapped steering wheel	●	●
Drilled aluminium pedals	●	●
Embossed kick plates	●	●
Soft-top with glass heated rear screen	●	●
Electric roof	●	●
Front electric windows	●	●
Passenger vanity mirror with lid in sunshade	●	●
Seating		
Leather upholstery	●	●
In car entertainment**		
Stereo CD tuner with RDS	●	●
Front speakers	●	●
Tweeters	●	●
Roll bar speakers	●	●
Remote stereo controls	●	●



4135mm



1270mm

1750mm
(1968mm including door mirrors)

Key ● Standard ○ Optional - Not available

[†] **Fuel consumption.** This test is designed to give an indication of on-road fuel consumption.

* **Maximum towing weights** are based on the ability of the car, with two occupants of 75kg each, to restart on a 12% gradient at sea level. At altitudes in excess of 1500 metres, engine output may drop with a reduction in towing capability. Extra weight, such as additional passengers or luggage, should also be deducted from the maximum towing weight.

** For further information please refer to your dealer.

EXTERIOR COLOURS



*Berlina Black**



*Deep Burgundy Metallic***



*Moon Rock Metallic**



*Silverstone Metallic**



New Formula Red



*Monza Red Pearl***



*Imola Orange Pearl***



*New Indy Yellow Pearl***



*Royal Navy Blue Pearl**



*Bermuda Blue Pearl***



*Nuerburgring Blue Metallic**

* Please note that these are non-standard colours and are available at an extra cost. ** Please note that these are premium colours and are available at an extra cost.

INTERIOR COLOURS



Black leather is available with all exterior colour options, except Nuerburgring Blue Metallic.



Red and Black leather is available with Berlina Black, Moon Rock Metallic, and Silverstone Metallic.



Red leather is available with Berlina Black, Moon Rock Metallic, and Silverstone Metallic.



Brown leather is available with Berlina Black, Moon Rock Metallic, Royal Navy Blue Pearl and Deep Burgundy Metallic.



Blue leather is available with Nuerburgring Blue Metallic.

The Honda S2000 is available in an extensive range of new striking colours. All interiors are fitted with high-grade, luxury leather in a choice of colours, that reflect the exterior colour selection. Smart aluminium and chrome finishes feature throughout, further enhancing the stylish design of the Honda S2000. Please contact your local dealer for further information.



?Why do we find it hard to talk about money

You've studied it. Talked about it. Dreamed about it. Now you have to pay for it. Just doesn't feel like part of the fun, somehow. So we thought, there should be a better way to do this. Not a quick-fix, easy-terms, one-size-fits-all deal, either. Finance that sounds too good to be true usually is. We were thinking 'simple', 'flexible' and 'convenient'. And that's what you get, right from making the deposit.

?So where do we start

With the deposit. Your current car or cash are both fine. You don't have either? No problem: we can work out a zero-deposit package, too.

?Done your sums

The most important part of any finance is the monthly payments. Only you know how much you can really afford. So tell us. That way, we can work out monthly payments to fit in with your budget. Our finance packages are flexible enough to work round just about anything. After that, it's up to you.

We give you choices right through the process. Including at the end of the agreement. You want to keep the car? Simple: make the final payment and it's all yours. Or, you can give it back.

As long as it's in good condition and within the agreed mileage, you can walk away with nothing more to pay*. And if you're ready for a new Honda, we'll arrange a part-exchange and a new finance package. Easy, really.

Making our finance more straightforward meant leaving out a few things. The long, complex forms. The dense technical jargon. The wait to see if you've got the go-ahead. We didn't think you'd miss them. We don't. All of which means you get your new Honda quicker.

Of course, none of this is any substitute for talking it over with your local Honda dealer. So now you know what to expect from a visit to us. When can we expect a visit from you?

Terms and Conditions

*Honda Aspirations only (Honda's PCP product).

Credit provided by Honda Finance Europe Plc. 470 London Road, Slough, Berkshire, SL3 8QY.





?Want to predict the future

The Honda S2000, like all Hondas, is made to our exacting standards. But we take nothing for granted. So the Honda S2000 is covered by a 3 year manufacturer's warranty*. You can extend this period of cover with a Hondacare Guarantee and give yourself peace of mind for up to a further 3 years. Hondacare Guarantee is unique and only available from authorised Honda Dealerships.

Just choose the period of cover you want - from 1 to 3 years. Then sit back and relax, knowing that help is only a telephone call away.

Unexpected repair bills will be settled immediately.

Further benefits include:

- Repairs carried out by Honda trained technicians.

- Guarantees the use of only Genuine Honda parts.

- Hondacare Assistance - Honda's comprehensive breakdown and recovery package.

Just ask your authorised Honda Dealership for more details.

?Like beneficial insurance rates

The Honda Owners Insurance scheme has been specially designed so that Honda owners receive beneficial insurance cover at competitive rates.

To obtain details of all the benefits included and to receive a quotation, please contact your authorised Honda dealer or call 0845 200 8000.

?Is help at hand when it really matters

With Honda it is. Because if you're unlucky enough to have an accident, we have a free Hondacare Accident Helpline that will sort all the details for you and make it a priority to get your car back on the road. In the event of an accident please telephone 0800 521 728.

*Subject to the Warranty terms and conditions listed on pages 15 and 16 of your service book.

?Shouldn't the last thing you think about be maintenance

A Hondacare Maintenance Plan** means you won't have to think about it at all. It covers you for all servicing and maintenance costs and can be paid for by Direct Debit in monthly installments. So you can get on with enjoying your car.

It's competitive and flexible.

All servicing is undertaken by Honda dealers. This gives you access to fully qualified technicians and an established network of dealers throughout the UK.

It means your car will only ever be serviced and repaired with genuine Honda parts.

It protects the value of your car. It's backed by Hondacare Assistance, giving you peace of mind 24 hours a day every day of the year.

It's backed by a Honda Manufacturer Warranty.

For full details, please contact your Honda dealer.

?Can your car get the service you do

We spend a lot of time working out the best service we can give to our customers. And you'd expect us to also come up with the best service for your car, too. So we designed Hondacare Budget Plan Servicing**.

This way, you can spread the cost of servicing your car with fixed monthly payments. It's available for new and used Honda cars, and for private and business users too.

**Terms and conditions apply.

9,000 Miles / 12 Months	
S2000	
Months	Miles
12	9,000
24	18,000
36	27,000
48	36,000
60	45,000
72	54,000
84	63,000
96	72,000
108	81,000
120	90,000
132	99,000
144 [†]	108,000

12,500 Miles / 12 Months	
Jazz • FR-V (Petrol and Diesel) CR-V (Petrol and Diesel) • Civic Hybrid Civic Type-R • Civic (Petrol and Diesel) Accord Saloon and Tourer (Petrol and Diesel)	
Months	Miles
12	12,500
24	25,000
36	37,500
48	50,000
60	62,500
72	75,000
84	87,500
96	100,000
108	112,500
120	125,000
132	137,500
144 [†]	150,000

[†]Should mileage exceed 144 months or 108,000/150,000 miles, please contact your local Honda dealer to obtain a Continuation Service book.

S2000	Transmission	CO ₂ (g/km)	VED Band	Fuel economy combined (l/100km/mpg)
2.0i VTEC Roadster	6MT	236	F	10.0/28.2
2.0i VTEC GT	6MT	236	F	10.0/28.2



?Ever tried a little blue sky thinking

We love this planet as much as you do. And we're well aware that a global corporation that builds cars has to take its responsibilities very seriously. And that's why we only ever build cars with the future in mind. A lot of damage has been done since the invention of the internal combustion engine, but thanks to cutting-edge technology we're aiming to cut it out altogether.

Our manufacturing plant in Swindon is reducing the amount of landfill waste it produces. At the going rate, we're on track to cut that figure to zero by 2010. The development of our 3R concept - reduce, reuse, recycle - allows us not only to apply our principles throughout the plant, but also provides an educational tool for local schools and councils who visit us on a regular basis.



We've made technological developments that radically reduce emissions too. Like the Insight. It's the most fuel-efficient sports coupé in existence thanks to its Integrated Motor Assist technology. The same technology you'll find in the Civic Hybrid, winner of Best Fuel Economy in 2003 and Best 1-1.4 litre Engine at the 2004 International Engine of the Year 2003 Awards and the BP Green Fleet award for vehicle innovation and Car Manufacturer of the year 2005. Our new generation i-series engines, such as our i-VTEC engine, have been on course since 1995 to produce 75% less HC (hydrogen and carbon atoms) and NOx (oxides of nitrogen) emissions by 2005.

Ahead of new regulations due to come into force in 2006, we've reduced our motorcycles' emissions and fuel consumption by 30%. And the production of road-going two-stroke engines is now a thing of the past. Even when it comes to boats, if you're after an outboard engine, with Honda you'll only ever get the cleaner four-stroke version.

At Honda, if we have an idea, we want to make it happen. Take the groundbreaking FCX fuel-cell electric vehicle, which produces only water as a by-product. The first car of its kind to obtain approval for commercialisation in the US, it's fuelled by the chemical reaction between hydrogen and oxygen - we've even built a solar-powered hydrogen fuelling station at our research institute in Los Angeles. It's the greenest vehicle on the planet, and it's already driving around the streets of Tokyo and LA.

Not only are we cutting environmentally damaging emissions, we're actively putting something back in. In association with The CarbonNeutral Company we are promoting projects that absorb, neutralise and offset the carbon dioxide emission produced by car driving. The Greener Driving Gift, offered by participating dealers to new Honda owners, neutralises CO₂ produced during the first month of driving. We are also planting forests in the UK, swapping kerosene burners for solar panels in Sri Lanka and introducing energy efficiency equipment in poorer homes across the USA. And there are more projects on the way.



We're also rewriting the rulebooks by changing the way people think about transport.

We know that cars have become so popular that the planet is becoming gridlocked. That's why we've introduced traffic-reduction schemes in Singapore, such as the Intelligent Community Vehicle System, which encourages shared use of vehicles in urban areas. We want to create more public space, reduce traffic, lower pollution and provide an improved living environment for everyone.

At Honda we want to fill the world with great ideas. Not pollution.



Honda Insight - First in the Sports/Coupé category of the Environmental Transport Association's Car Buyers guide 2002

?Why stop when you reach the limit

Think of some of the world's most innovative creations. The people who made them dared to challenge convention. At Honda, we let nothing get in the way of a good idea. We encourage our designers to test the boundaries of science as well as their own imaginations. That's why our cars, motorcycles, ATVs, powerboat engines and power equipment products are used the world over, consistently winning new awards, new accolades and new friends.

But it doesn't stop there. After witnessing an aerobatics display as a schoolboy our founder, Soichiro Honda, dreamed of creating an aeroplane. Eighty-seven years later our engineers are putting the finishing touches to the HondaJet. True to Honda's belief in finding solutions through innovation and imagination, the jet challenges standard aircraft design. Its HF118 turbofan engines are located on the upper sides of the wings, part of a groundbreaking design that reduces drag at high speed and increases fuel efficiency by 40%. This break from conventional design also allows for 30% more cabin space. It goes to show what you can achieve by letting your imagination run free.

On the ground our desire to innovate is as strong as it's ever been. This applies as much to bicycles as it does to Formula-1 racing cars. On two wheels, we have recently perfected the RNO1 downhill mountain bike, with its unique gearbox system that allows cyclists to change gear without the need to pedal.

This revolutionary design was born out of an enthusiastic idea that was allowed to flourish, rather than a design requirement. On the track, our Formula-1 programme saw young British contender Jenson Button rise to the podium ten times in 2004, the Honda BAR Team achieving second place in the Constructor's Championship, and the Honda engines proving credible and consistent rivalry to those of the dominant Ferrari team.

Some innovations come from the heart. One Honda engineer, who hated diesel engines so much, made it his mission to revolutionise them. The i-CTDi sets a new benchmark in diesel technology. High in torque and low in fuel consumption, it's unique closed deck aluminium construction, one of the only aluminium diesel engines on the market, offers power, cleanliness and an incredibly low noise output, creating a level of performance that rivals the very best in the market. It's part of our constant mission to reduce emissions and create cleaner vehicles – like the FCX series. These vehicles use hydrogen fuel cells as their power source, producing only water as a by-product. When it comes to engines, you don't get much cleaner than that.

And then there's ASIMO. Our famous robot.

With his ground breaking abilities in balance, manoeuvrability, face and voice recognition, he represents our vision of creating technologies that go way beyond our everyday perceptions of transport and mobility.

Our latest inspiration comes in the form of an intelligent night-vision system, which uses infrared cameras to see in the dark and is the world's first system to detect pedestrians or moving, heat-emitting objects such as animals that are in the vehicles path, or even judged to be moving into that path. The system warns the driver via an audio caution linked to a 'heads-up' display above the dashboard.

Even when it comes to safety we look beyond the expected. As one of the first manufacturers to develop pedestrian safety technology, we continue to place importance in this area. Our latest innovation is the 'pop-up' bonnet system. It uses sensors in the bumper to indicate whether an impact with a pedestrian has occurred. This triggers a mechanism that raises the rear portion of the engine hood away from the hard components found underneath it. Our Head Injury Criteria are reduced by up to 40% when this system is fitted.

All these innovations are in constant development, and there are new ideas being born every minute. We are always looking to improve, to make our products cleaner, safer, more efficient. It's all part of our continuing mission to push back the boundaries of science, to turn inspirational ideas into reality.





Jazz



Civic



Civic Type-R



Civic Hybrid



FR-V



CR-V



Accord Saloon



Accord Tourer



Honda S2000

?What do all Honda cars have in common

More than you might think to look at them. They're all unique. But every Honda is designed to excite, inspire and perform.

How do we turn that dream into reality? Through world-class engineering and innovation. Show us a boundary, and we'll push it, whether in aesthetics, safety, driving dynamics or engine technology. Our VTEC engines deliver the exact amount of power needed, at the precise moment it's asked for. Our new i-CTDi is quiet and refined like our petrol engines but with all the fuel consumption and tax benefits of diesel. And our multi award-winning Integrated Motor Assist (IMA) ingeniously combines petrol and electric hybrid technology to save fuel, tax and money.

We're obsessed with detail and build quality. If a conventional process doesn't produce the results we want, we'll invent a new one that does. Like our advanced dip-and-roll painting technique, designed to prevent air bubbles forming under the surface of the paint.

We even build some of the machines that build our cars. The Civic 3 door, Civic 5 door and CR-V all start life at our Swindon plant, in which we've invested £1.15 billion since its opening.

Making it one of the world's most sophisticated production lines. But it's not just what's inside our buildings that meets with others' approval: in October 2002, the Chartered Institute of Building gave us its prestigious 'Building Award' for our second European car plant.

But there's another, even more important element you'll find in every Honda. A shared heritage, the engineering equivalent of DNA. Which is? Racing. It was the lifelong passion of our founder Soichiro Honda, and we're still competing at the highest level today. In 2002, our Synchro Motorsport Team drove the Civic Type-R to 17 British Touring Car Championship (BTCC) victories – including the overall Driver's and Team titles.

As well as providing the perfect proving ground for new technology, racing teaches the importance of safety. Which is why we've built the world's largest crash-testing facility. We've also developed the most advanced crash-test dummy in existence, the POLAR II: the AA presented us with a special award for our work in developing pedestrian-friendly vehicles. And of course, all that work is in your new Honda, too.

Every Honda model is a product of the power of dreams. It's what brings them all together. And makes them completely unique.



HONDA
S2000

HONDA
S2000

Colours

Moon Rock Metallic

Royal Navy Blue Pearl

Silverstone Metallic

New Formula Red

Nuerburgring Blue Metallic

Imola Orange Pearl

Monza Red Pearl

Berlina Black

New Indy Yellow Pearl

Bermuda Blue Pearl

Deep Burgundy Metallic

HONDA S2000 Colours

Silverstone Metallic

	Black leather	Red/Black leather	Red leather	Brown leather	Blue leather
2.0i VTEC Roadster	●	○	○	-	-
2.0i VTEC GT	●	○	○	-	-

● standard ○ optional - not available

Honda S2000 Colour and Trim

Nuerburgring Blue Metallic

	Black leather	Red/Black leather	Red leather	Brown leather	Blue leather
2.0i VTEC Roadster	-	-	-	-	●
2.0i VTEC GT	-	-	-	-	●

● standard ○ optional - not available

Honda S2000 Colour and Trim

Monza Red Pearl

	Black leather	Red/Black leather	Red leather	Brown leather	Blue leather
2.0i VTEC Roadster	●	-	-	-	-
2.0i VTEC GT	●	-	-	-	-

● standard ○ optional - not available

Honda S2000 Colour and Trim

New Indy Yellow Pearl

	Black leather	Red/Black leather	Red leather	Brown leather	Blue leather
2.0i VTEC Roadster	●	-	-	-	-
2.0i VTEC GT	●	-	-	-	-

● standard ○ optional - not available

Honda S2000 Colour and Trim

Deep Burgundy Metallic

	Black leather	Red/Black leather	Red leather	Brown leather	Blue leather
2.0i VTEC Roadster	●	-	-	○	-
2.0i VTEC GT	●	-	-	○	-

● standard ○ optional - not available

Honda S2000 Colour and Trim

Moon Rock Metallic

	Black leather	Red/Black leather	Red leather	Brown leather	Blue leather
2.0i VTEC Roadster	●	○	○	○	-
2.0i VTEC GT	●	○	○	○	-

● standard ○ optional - not available

Honda S2000 Colour and Trim

Royal Navy Blue Pearl

	Black leather	Red/Black leather	Red leather	Brown leather	Blue leather
2.0i VTEC Roadster	●	-	-	○	-
2.0i VTEC GT	●	-	-	○	-

● standard ○ optional - not available

Honda S2000 Colour and Trim

New Formula Red

	Black leather	Red/Black leather	Red leather	Brown leather	Blue leather
2.0i VTEC Roadster	●	-	-	-	-
2.0i VTEC GT	●	-	-	-	-

● standard ○ optional - not available

Honda S2000 Colour and Trim

Imola Orange Pearl

	Black leather	Red/Black leather	Red leather	Brown leather	Blue leather
2.0i VTEC Roadster	●	-	-	-	-
2.0i VTEC GT	●	-	-	-	-

● standard ○ optional - not available

Honda S2000 Colour and Trim

Berlina Black

	Black leather	Red/Black leather	Red leather	Brown leather	Blue leather
2.0i VTEC Roadster	●	○	○	○	-
2.0i VTEC GT	●	○	○	○	-

● standard ○ optional - not available

Honda S2000 Colour and Trim

Bermuda Blue Pearl

	Black leather	Red/Black leather	Red leather	Brown leather	Blue leather
2.0i VTEC Roadster	●	-	-	-	-
2.0i VTEC GT	●	-	-	-	-

● standard ○ optional - not available

Honda S2000 Colour and Trim