



Service Manual Update: Rear Window Replacement

The procedure in this bulletin updates the rear window replacement procedure on page 20-38 of the 2000 S2000 Service Manual.

NOTE: See S/B 00-037, *Rear Window Is Creased, Clouded, or Scratched*, before replacing the rear window.

PARTS INFORMATION

Aluminum Pop Rivet, 3/16" x 1/2" (8 required), commercially available

Aluminum Pop Rivet, 3/16" x 3/8" (3 required), commercially available

Aluminum Washer, 3/16" (11 required), commercially available

Rear Window:
P/N 86317-S2A-003, H/C 6244537

TOOL INFORMATION

Eye protection (face shield or safety goggles)

Drill

6 mm Drill bit

Pop rivet gun

Body Vise Grip pliers

REQUIRED SPECIAL TOOLS

Rear Fender Cover:
P/N 07ZAZ-S2AA000, H/C 6552053

WARRANTY CLAIM INFORMATION

None. This bulletin is for information only.

REPAIR PROCEDURE

NOTE: Page references in this procedure refer to the 2000 S2000 Service Manual.

1. Remove the spare tire cover and the spare tire.
2. Open the roof, and remove these items:
 - ♦ Both seats (see page 20-64)
 - ♦ Door sill trim (see page 20-48)
 - ♦ Rear side trim (see page 20-49)
 - ♦ Roll bar lower trim (see page 20-49)
3. Close the roof, and remove the clips that hold the rear tray trim, the rear tray side trim, and the rear tray (see page 20-50).
4. Remove the rear tray, the rear tray trim, and the rear console back board through the trunk.
5. Lift the roof fabric that overlaps the top of the rear window, and remove the neoprene cover from the roof zipper. The neoprene may come off in small pieces; be sure to remove all the pieces.

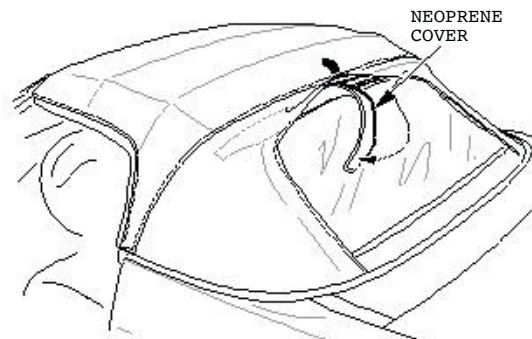

6. Open the roof, and lift up the center console. Turn the console to the side to expose the lower screws (see page 20-55).
7. Remove the rear console glove box and the rear console box (see page 20-56).
8. Close the roof, and remove both roll bars (see page 20-51).



9. Remove the 11 nuts and the retainers that attach the convertible top to the body.

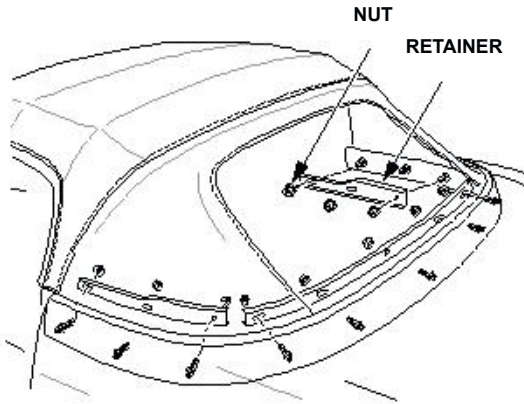

10. Open the roof halfway, and remove the two clips on each side of the car, securing the rain rail to the quarter panel (see page 20-34).

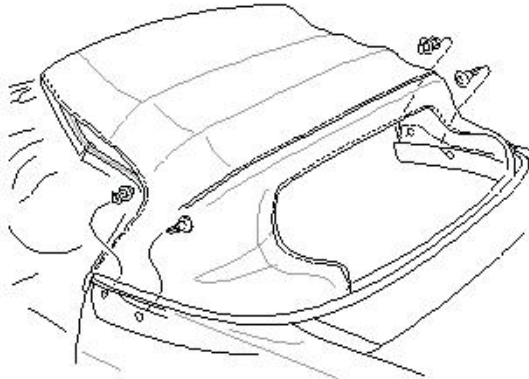

11. Place an S2000 rear fender cover across the trunk, then lift up the rain rail, and set it on top of the fender cover.

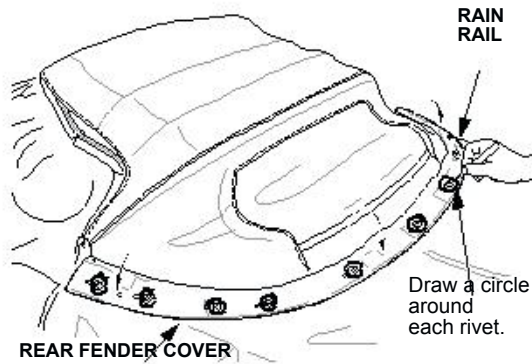

12. Using a marker or white-out, draw a circle around each of the 11 aluminum rivets.

13. Pull the rain rail up, and turn it inside-out.

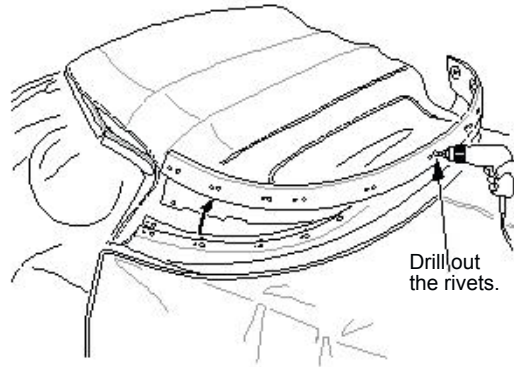

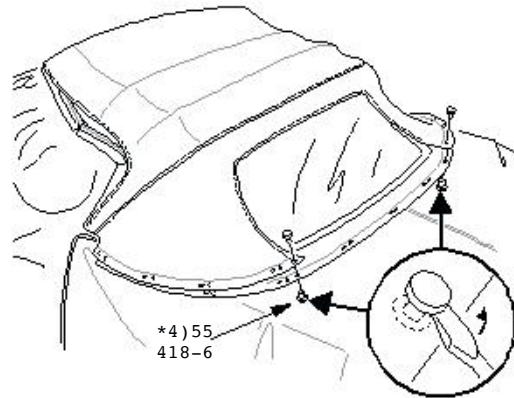

14. While wearing eye protection, rest the rain rail on the roof, drill out the rivets with a 6 mm drill bit, and remove the rail.

15. Pry apart the two brass rivets that attach the lower edge of the roof to the window.

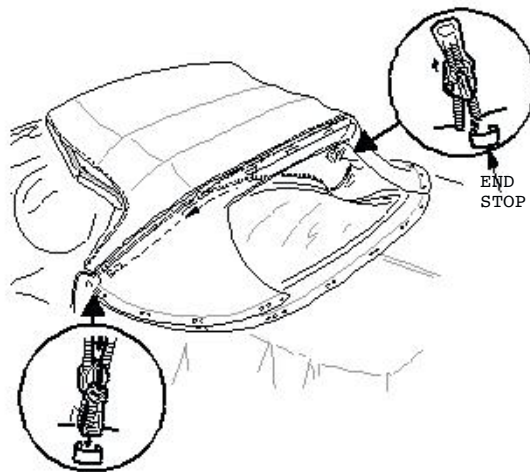

16. Pull back the Velcro flap to expose the zipper, and then remove the end stops from both ends.



17. Carefully unzip the window from the roof. Hold the pull tab tightly so you don't drop it into any crevices.
18. Zip the new window onto the roof, making sure the  marks are lined up. It may take several attempts to line up the marks.

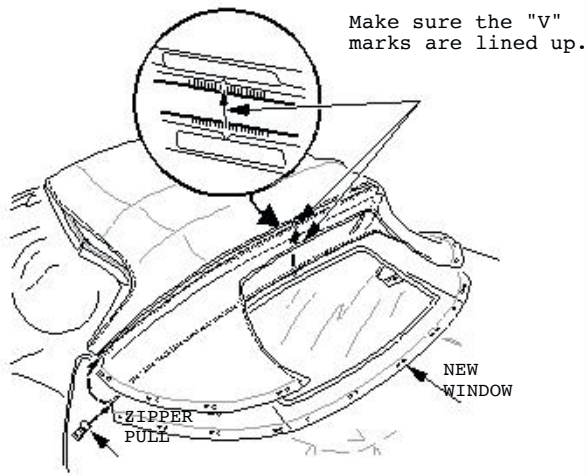



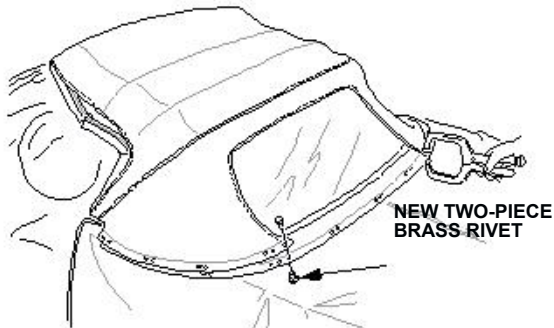



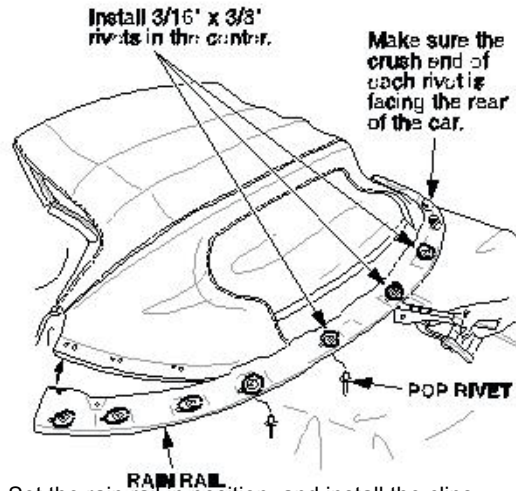

19. Install the zipper end stops.
20. With body Vise Grips, secure the lower edge of the window to the roof with new two-piece brass rivets.



21. Reassemble the roof, the window, and the rain rail with new pop rivets. Make sure the crush end of each rivet is facing the rear of the car when the rain rail is sitting in place.



22. Set the rain rail in position, and install the clips between the quarter panel and the rain rail.
23. Install the 11 nuts and the retainers, and torque the nuts to 9.8 N·m (7.2 lb-ft).
24. Reinstall these items:
 -  Both roll bars
 -  Rear console glove box and rear console box
 -  Roll bar lower trim
 -  Rear side trim
 -  Door sill trim
 -  Both seats
 -  Rear tray side trim
 -  Rear tray and rear tray trim
 -  Spare tire and spare tire cover