

## PARTS LIST

**Security System:  
P/N 08E51-S84-101**

2 Remote controls



Control unit

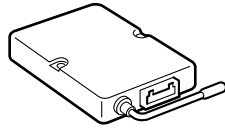

LED  
(Not used.)



Push nut  
(Not used.)



2-Pin connector

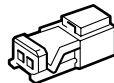

Disarm switch

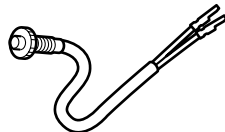

Window decal

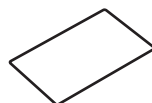

3-Pin connector  
(Not used.)

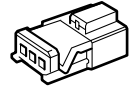

Nut



Washer



User's Information Manual



2 Washer-screws, 4 x 30 mm



**Attachment Kit:  
P/N 08E55-S2A-100B**

Security system harness

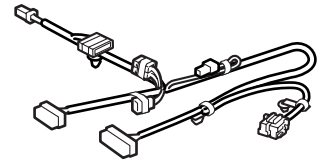

Control unit bracket

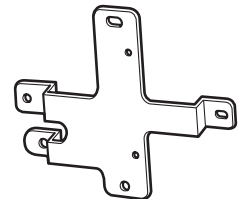

Relay A (black)

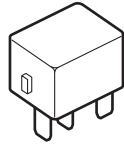

Relay B (gray)

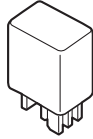

Fuse label

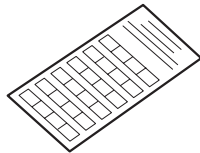

3 Grommets

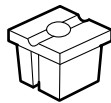

3 Self-tapping screws



7 Wire ties

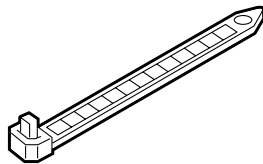

Wire tie with clip

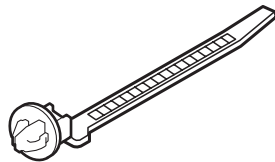

2 Flange nuts



EPT sealer

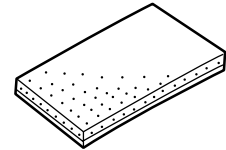

Seal

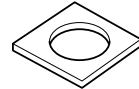

**TOOLS AND SUPPLIES REQUIRED**

Small flat-tip screwdriver

Phillips screwdriver

Center punch

Eye protection (face shield, safety goggles, etc.)

Drill

5.5 mm Drill bit

12 mm Holesaw

Tape measure

File

Felt-tip pen

Ratchet

10 mm, 12 mm, and 14 mm Sockets

Piece of cardboard

Diagonal cutters

Electrical tape

Torque wrench

Shop towel

**Illustration of Security System Installed on the Car**

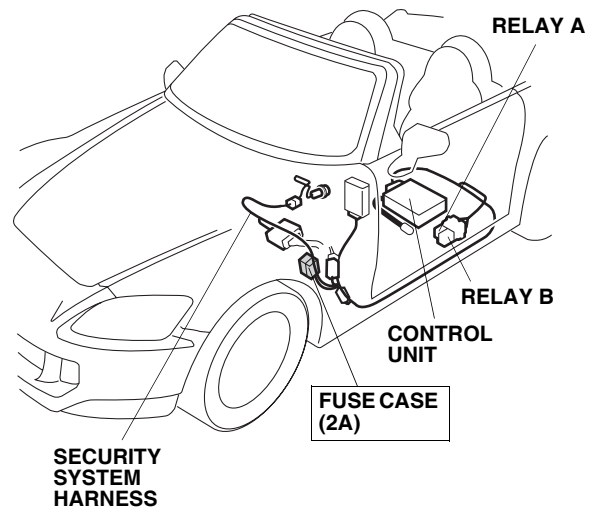

## Adjusting the Control Unit

Use a small flat-tip screwdriver to change the mode switch and the horn/siren switch and to adjust sensitivity. The horn/siren switch must be set in the "HORN" position.

### Mode Switch:

- Set the mode switch according to the customer's preference.
- Refer to the User's Information Manual for the explanation of each mode.

### Glass Breakage Sensor:

Do not attach anything like adhesive tape over the holes; this is a microphone pickup.

### Sensitivity Adjustment Knob:

- Adjust the sensitivity only if the customer requests it; the sensitivity adjustment of the glass breakage sensor is factory-set.
- Be careful when you adjust the sensitivity; if you raise the sensitivity too much, the security system can give a false alarm, and if the sensitivity is too low, the security system may not work even if glass is broken.

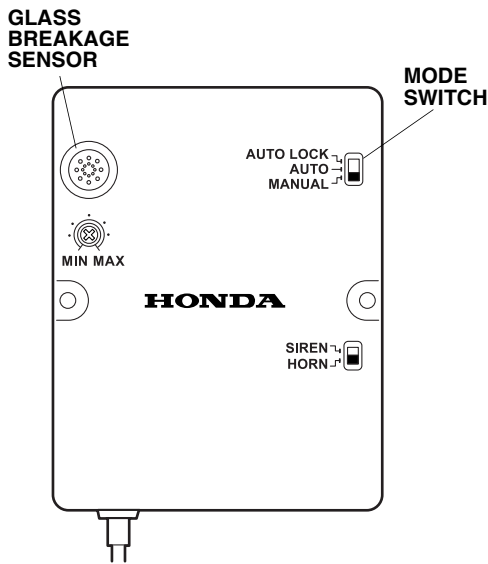

## INSTALLATION

**Customer Information:** The information in this installation instruction is intended for use only by skilled technicians who have the proper tools, equipment, and training to correctly and safely add equipment to your vehicle. These procedures should not be attempted by "do-it-yourselfers."

1. Make sure you have the anti-theft code for the radio, then write down the radio station presets.
2. Disconnect the negative cable from the battery.
3. Remove the front left door sill trim (three retaining clips).

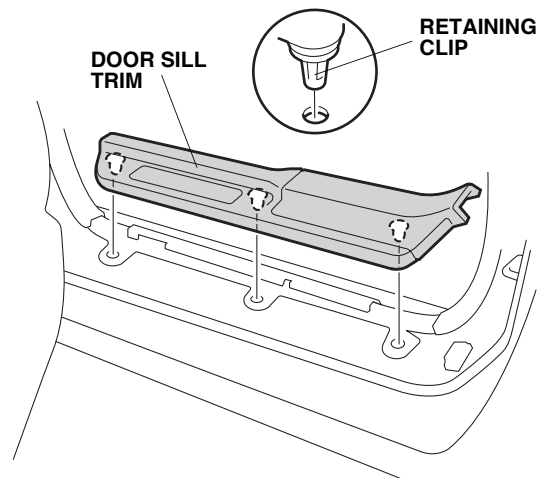

4. Remove the left kick panel (three clips).

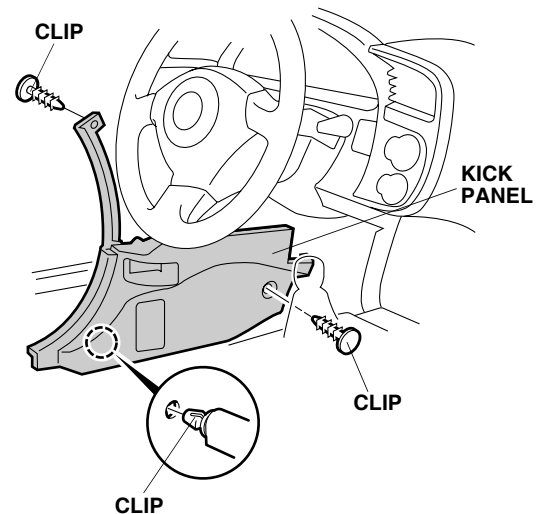

- Remove the driver's lower cover (turn the knob clockwise, and nine clips).

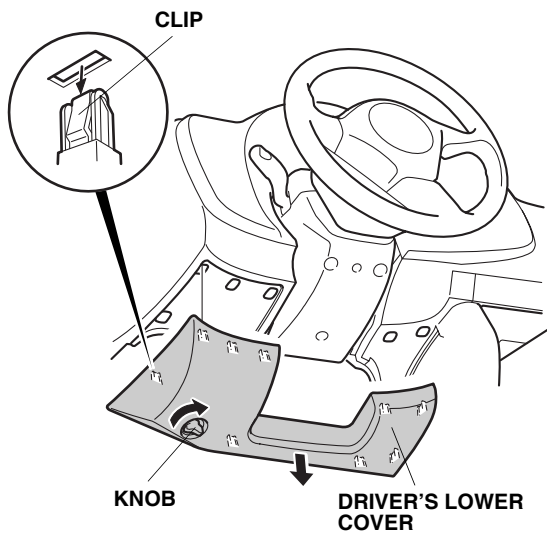

- Remove the driver's seat (four bolts, and unplug the two connectors). Place the seat on a piece of cardboard.

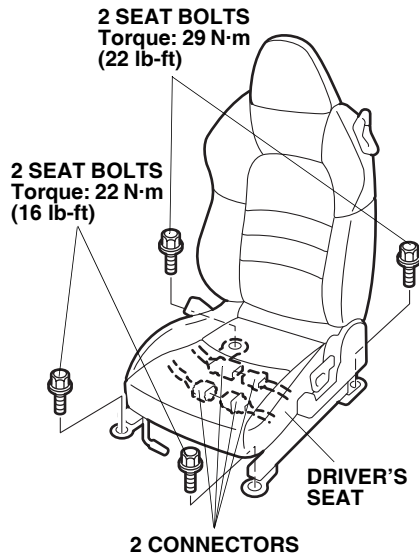

- To prevent damage to the vehicle, cover both ends of each seat rail with a shop towel.

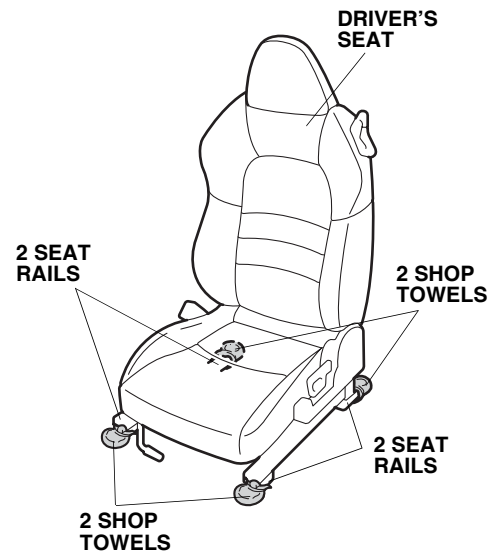

- Push the three grommets into the square holes in the bottom of the driver's seat cushion.

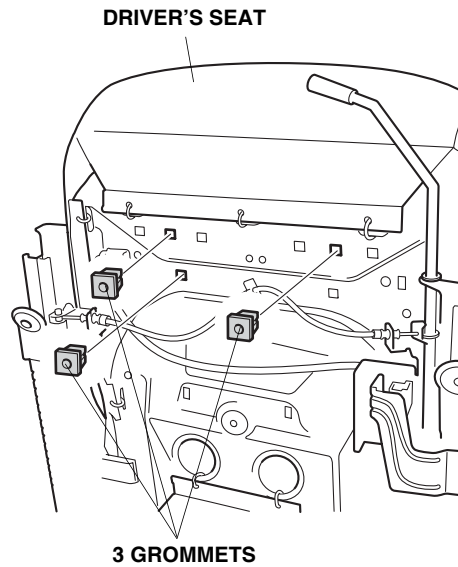

9. Install the control unit on the control unit bracket (two 4 x 30 mm screws and two flange nuts).
10. Attach the wire tie with clip to the antenna, then push the clip into the hole in the control unit bracket.

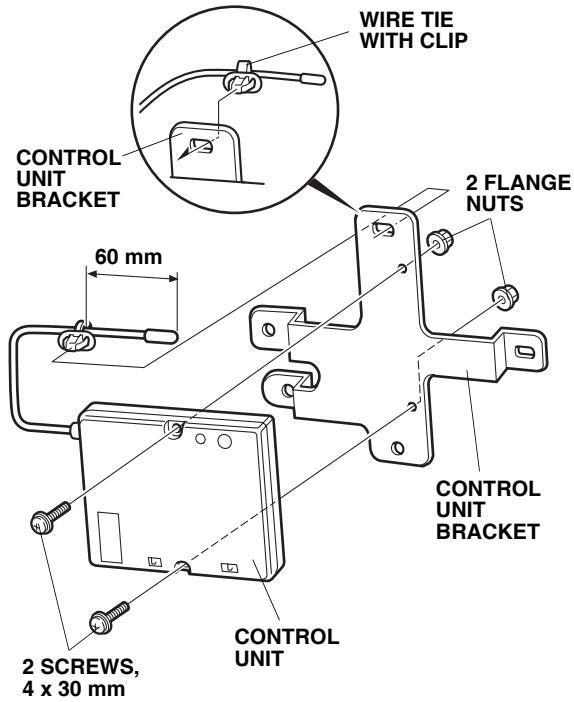

11. Attach EPT sealer to the control unit bracket, as shown.

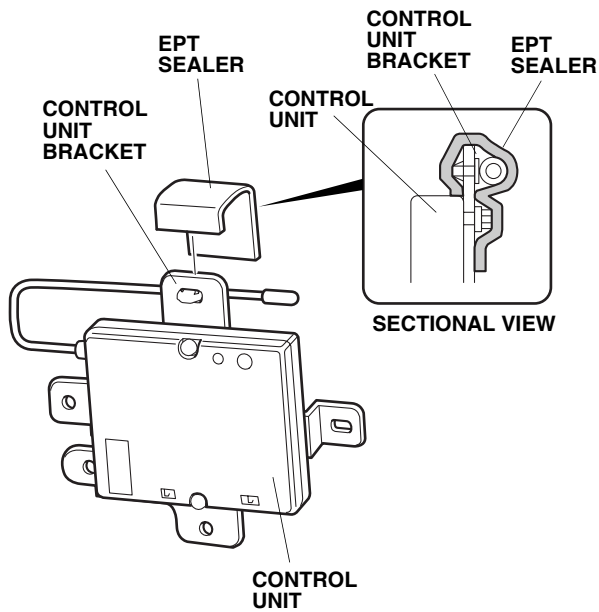

12. Install the control unit bracket onto the bottom of the driver's seat cushion (three self-tapping screws).

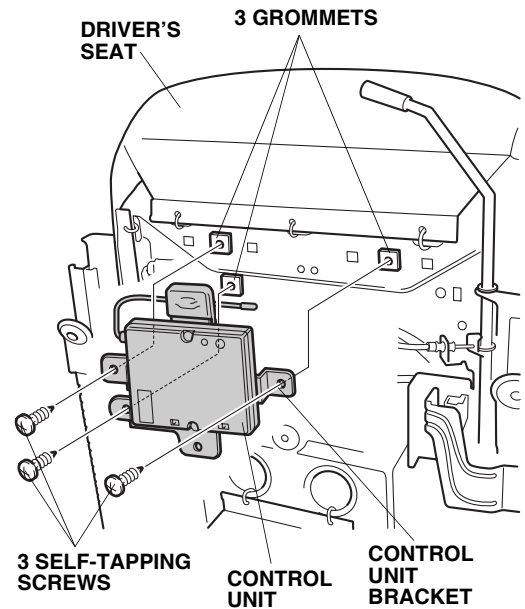

13. Mark the driver's lower cover in the position shown.
14. While wearing eye protection, lightly center-punch the mark, and drill a 12 mm hole:
  - First drill a pilot hole with a 5.5 mm bit, then finish with a 12 mm holesaw.
  - Remove any burrs.

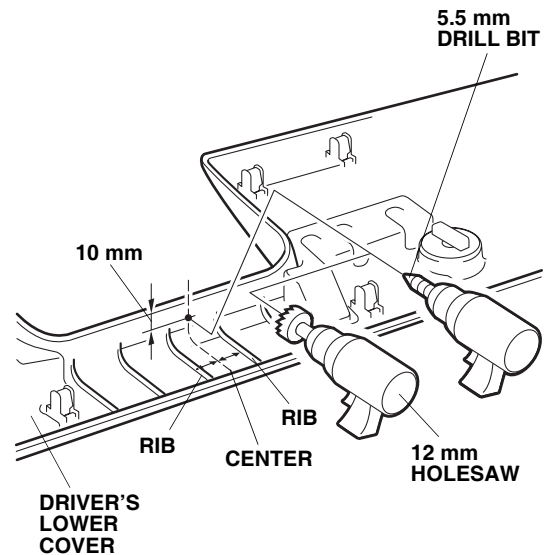

- Route the terminal ends of the disarm switch through the hole you just drilled, and secure it with the washer and the flange nut from the kit.

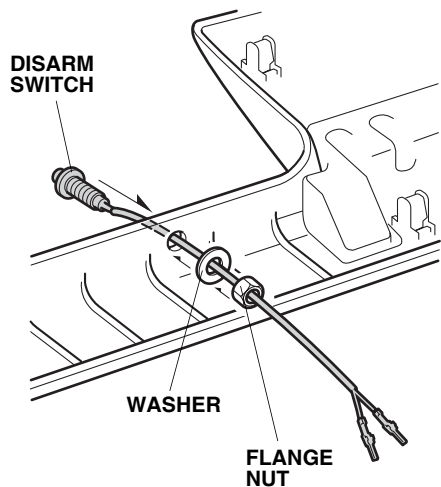

- Get the 2-pin connector included in the kit. Firmly push the disarm switch terminals into the 2-pin connector until they click into position, then lower the lock.

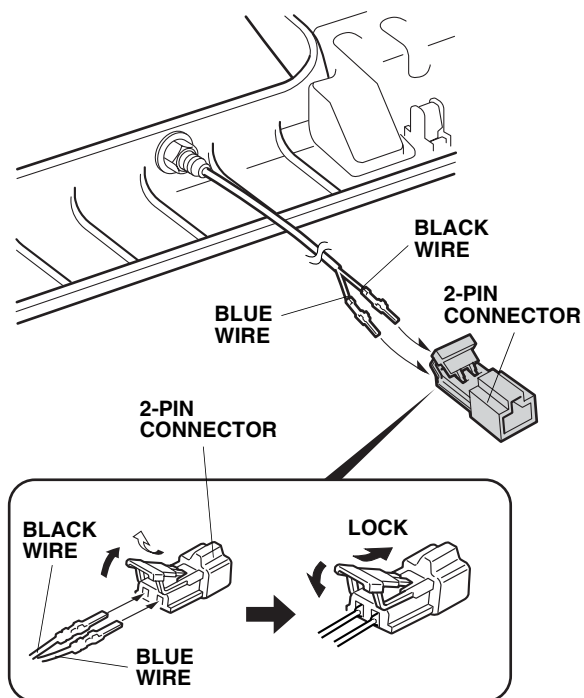

- On the driver's side, lift up the floor carpet, then route the 22-pin connector (green) of the security system harness and security system harness relay block through the cutout in the floor carpet.
- Align the green tape of the security system harness with the corrugated tube of the vehicle harness, then secure them with one wire tie.

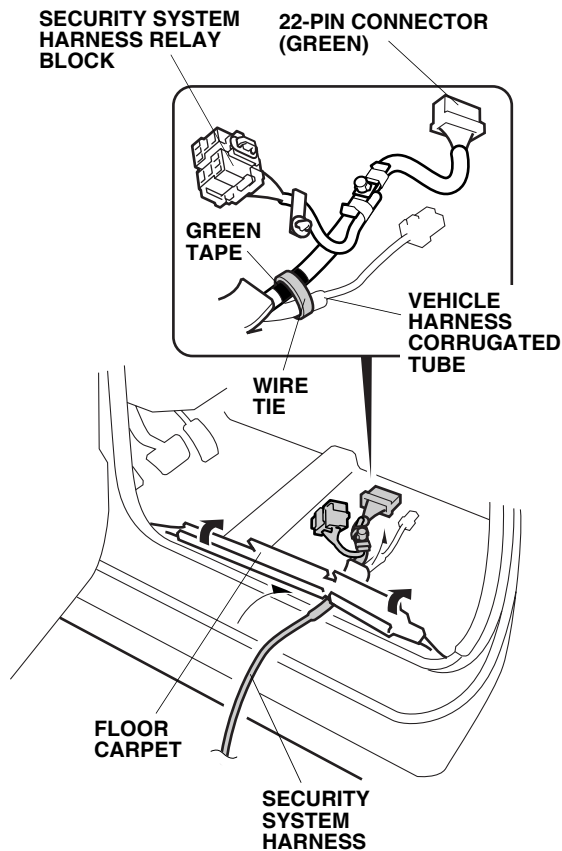

- Plug relay A (black) and relay B (gray) into the security system harness relay block.

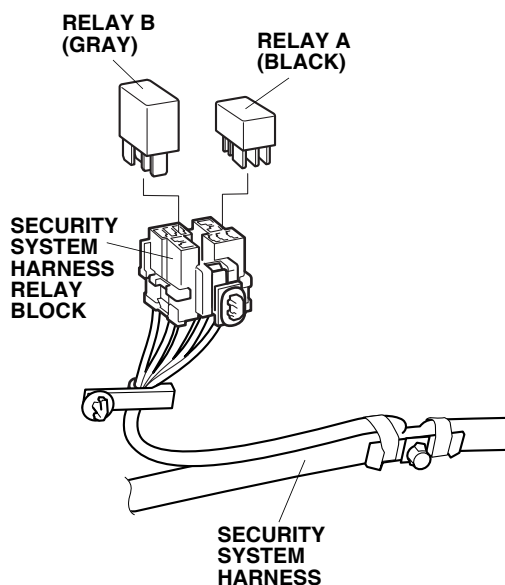

- Along the door opening, secure the security system harness to the vehicle harness with two wire ties.

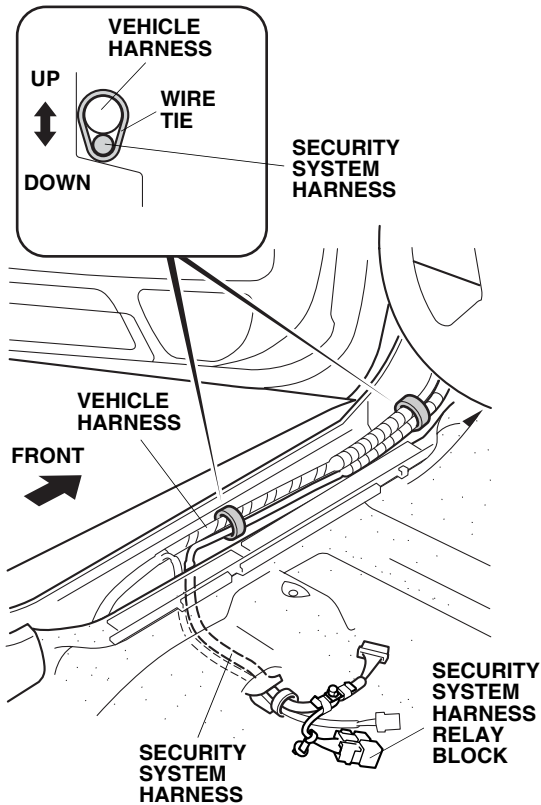

- Route the security system harness forward and under the carpet.
- Remove the blue tape from the vehicle 4-pin connector, then connect the vehicle 4-pin connector to the security system harness 4-pin connector.

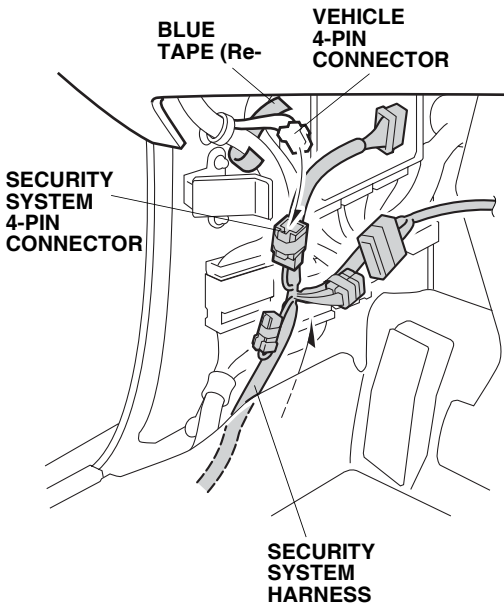

- Attach the two fuse labels (OPTION FUSE 3A) to the fuse case on the security system harness.
- Unplug the vehicle 18-pin connector from the keyless entry control unit, and plug the 18-pin connectors of the security system harness into the vehicle 18-pin connector and keyless entry control unit.

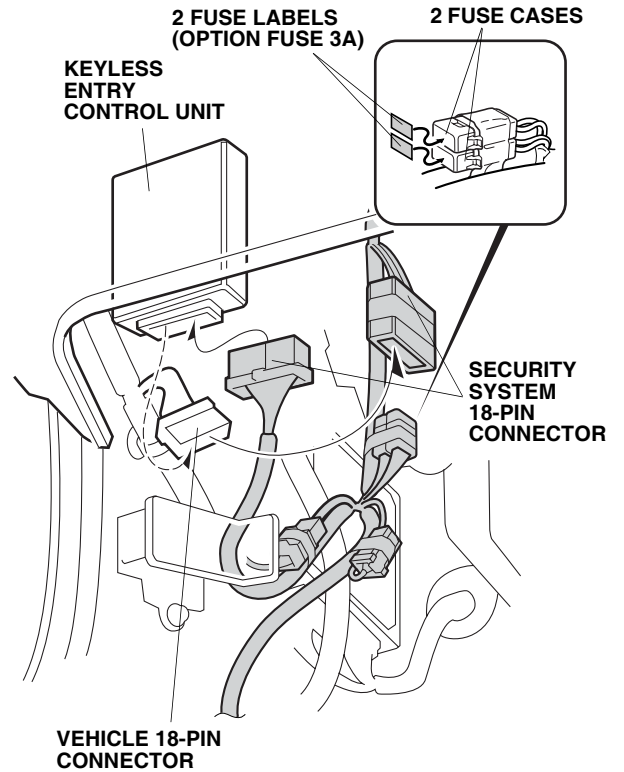



25. Plug the security system harness 2-pin connector into the disarm switch 2-pin connector, then slide the 2-pin connector onto the vehicle connector holder.

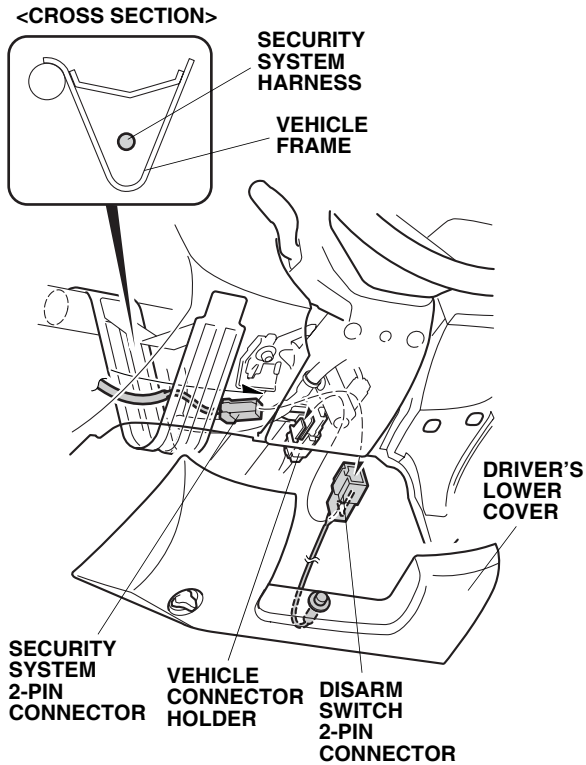

26. Secure the clip on the security system harness to the vehicle frame.

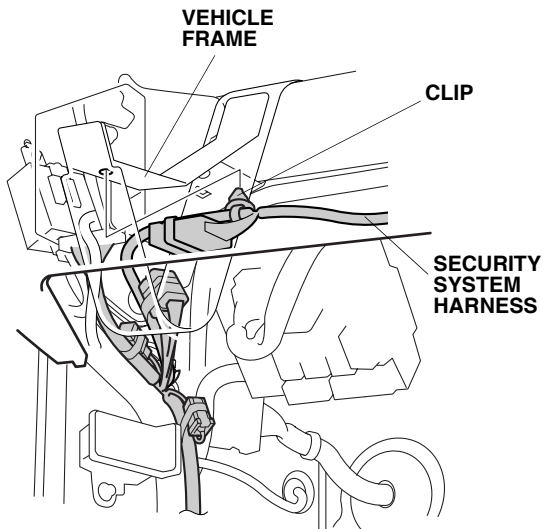

27. Reinstall the driver's lower cover.
28. Bundle the excess of the disarm switch harness and secure it to the instrument panel using two wire ties.

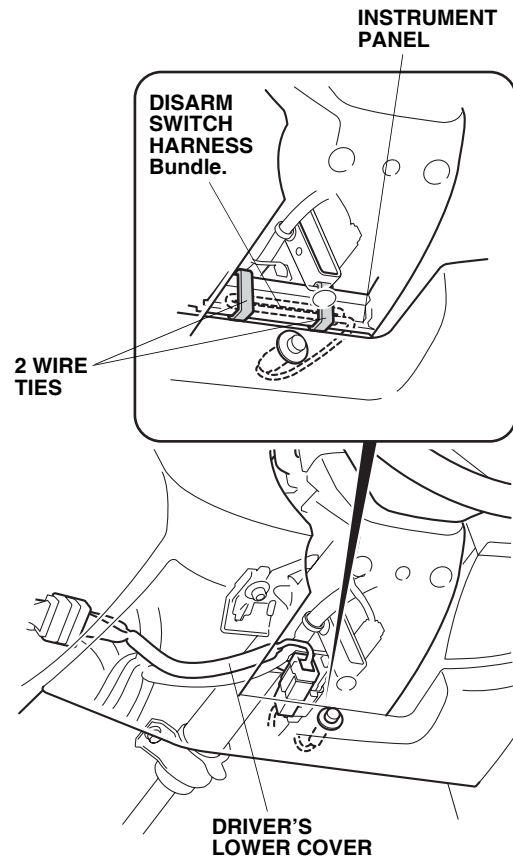

29. Secure the security system harness to the vehicle harness with two wire ties as shown.

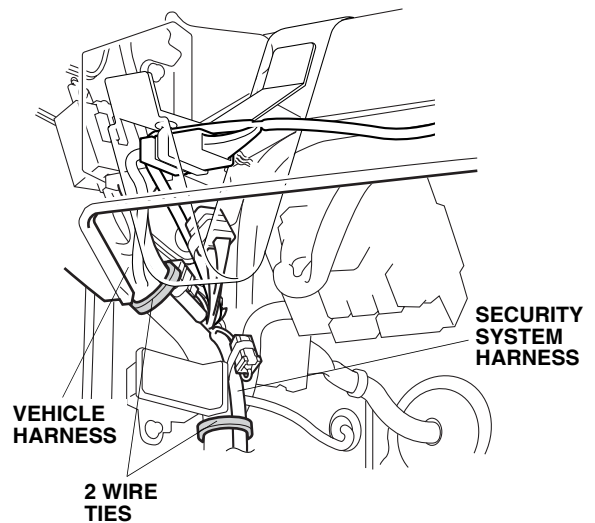



30. Tilt the driver's seat-back forward, then reach under the front of the seat, and plug the 22-pin connector (green) of the security system harness into the control unit.

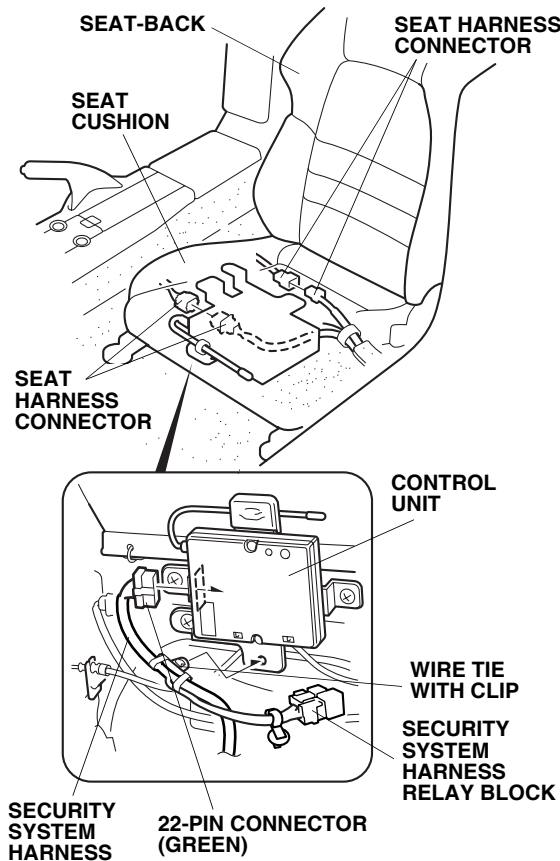

31. Attach a seal to the clip on the security system harness relay block.
32. Secure the clip on the security system harness relay block and the clip on the security system harness to the bottom of the driver's seat cushion.

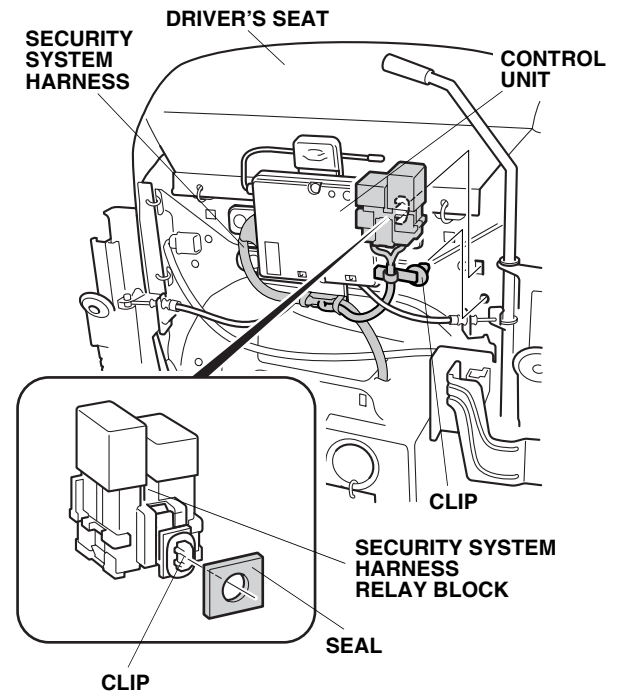

33. Push the wire tie with clip of the security system harness into the hole in the control unit bracket.
34. Plug in the seat harness connectors, then reinstall the driver's seat. Torque the rear seat bolts to 29 N·m (22 lb-ft), and torque the front seat bolts to 22 N·m (16 lb-ft).
35. Check that all wire harnesses are routed properly and all connectors are plugged in.
36. Reinstall all removed parts.
37. Reconnect the negative cable to the battery.
38. Reset the radio station presets and clock.
39. Check operation of the security system according to the security system User's Information Manual. The LED indicator is located in the instrument cluster.