

# 2005 S2000 Online Reference Owner's Manual

Use these links (and links throughout this manual) to navigate through this reference.  
For a printed owner's manual, click on authorized manuals or go to [www.helminc.com](http://www.helminc.com).

## Contents

---

### Owner's Identification Form

<b>Introduction</b> .....	<b>i</b>
<b>A Few Words About Safety</b> .....	<b>ii</b>
<b>Your Vehicle at a Glance</b> .....	<b>3</b>
Main controls	
<b>Driver and Passenger Safety</b> .....	<b>5</b>
Seat belts, SRS, and child protection.	
<b>Instruments and Controls</b> .....	<b>37</b>
Indicators, gauges, dashboard, and steering column.	
<b>Features</b> .....	<b>73</b>
Heating and Cooling, audio, steering wheel and cruise control	
<b>Before Driving</b> .....	<b>99</b>
Fuel, vehicle break-in, and cargo loading.	
<b>Driving</b> .....	<b>111</b>
Engine and transmission operation.	
<b>Maintenance</b> .....	<b>121</b>
Schedules, fluid checking, minor services, and vehicle storage.	
<b>Taking Care of the Unexpected</b> .....	<b>157</b>
Flat tire, dead battery, overheating, fuses.	
<b>Technical Information</b> .....	<b>181</b>
Vehicle specifications, tires, fuels, and emissions controls.	
<b>Warranty and Customer Relations (U.S. and Canada)</b> .....	<b>193</b>
Warranty and contact information.	
<b>Authorized Manuals (U.S. only)</b> .....	<b>197</b>
How to order.	
<b>Index</b> .....	<b>I</b>

### Service Information Summary

Fluid capacities and tire pressures.

## Owner's Identification

---

OWNER \_\_\_\_\_  
\_\_\_\_\_

ADDRESS \_\_\_\_\_

STREET

\_\_\_\_\_ CITY

STATE/PROVINCE

ZIP CODE/  
POSTAL CODE

V. I. N. \_\_\_\_\_

DELIVERY DATE \_\_\_\_\_

(Date sold to original retail purchaser)

DEALER NAME \_\_\_\_\_ DEALER NO. \_\_\_\_\_

ADDRESS \_\_\_\_\_

STREET

\_\_\_\_\_ CITY

STATE/PROVINCE

ZIP CODE/  
POSTAL CODE

OWNER'S SIGNATURE \_\_\_\_\_

DEALER'S SIGNATURE \_\_\_\_\_

This Owner's Manual should be considered a permanent part of the vehicle and should remain with the vehicle when it is sold.

This Owner's Manual covers all models of the S2000. You may find descriptions of equipment and features that are not on your particular model.

The information and specifications included in this publication were in effect at the time of approval for printing. Honda Motor Co., Ltd. reserves the right, however, to discontinue or change specifications or design at any time without notice and without incurring any obligation whatsoever.

Congratulations on your selection of the 2005 Honda S2000. We are certain you will be pleased with your purchase of one of the most sophisticated and technologically-advanced sports cars in the world.

One of the best ways to enhance the enjoyment of your new vehicle is to read this manual. In it, you will learn how to operate its driving controls and convenience items. Afterwards, keep this owner's manual in your vehicle so you can refer to it at any time.

Several warranties protect your new vehicle. Read the warranty booklet thoroughly so you understand the coverages and are aware of your rights and responsibilities.

Maintaining your vehicle according to the schedules given in this manual helps to keep your driving trouble-free while it preserves your investment. When your vehicle needs maintenance, keep in mind that your dealer's staff is specially trained in servicing the many systems unique to your vehicle. Your dealer is dedicated to your satisfaction and will be pleased to answer any questions and concerns.

As you read this manual, you will find information that is preceded by a **NOTICE** symbol. This information is intended to help you avoid damage to your vehicle, other property, or the environment.

## California Proposition 65 Warning

**WARNING:** This product contains or emits chemicals known to the State of California to cause cancer and birth defects or other reproductive harm.

## Event Data Recorders

This vehicle is equipped with one or more recording devices commonly referred to as event data recorders or sensing and diagnostic modules.

## A Few Words About Safety

---

Your safety, and the safety of others, is very important. And operating this vehicle safely is an important responsibility.

To help you make informed decisions about safety, we have provided operating procedures and other information on labels and in this manual. This information alerts you to potential hazards that could hurt you or others.

Of course, it is not practical or possible to warn you about all the hazards associated with operating or maintaining your vehicle. You must use your own good judgement.

You will find this important safety information in a variety of forms, including:

- **Safety Labels** — on the vehicle.
- **Safety Messages** — preceded by a safety alert symbol  and one of three signal words: **DANGER**, **WARNING**, or **CAUTION**. These signal words mean:

 **DANGER**

You **WILL** be **KILLED** or **SERIOUSLY HURT** if you don't follow instructions.

 **WARNING**

You **CAN** be **KILLED** or **SERIOUSLY HURT** if you don't follow instructions.

 **CAUTION**

You **CAN** be **HURT** if you don't follow instructions.

- **Safety Headings** — such as Important Safety Reminders or Important Safety Precautions.
- **Safety Section** — such as Driver and Passenger Safety.
- **Instructions** — how to use this vehicle correctly and safely.

This entire book is filled with important safety information — please read it carefully.

# Your Vehicle at a Glance

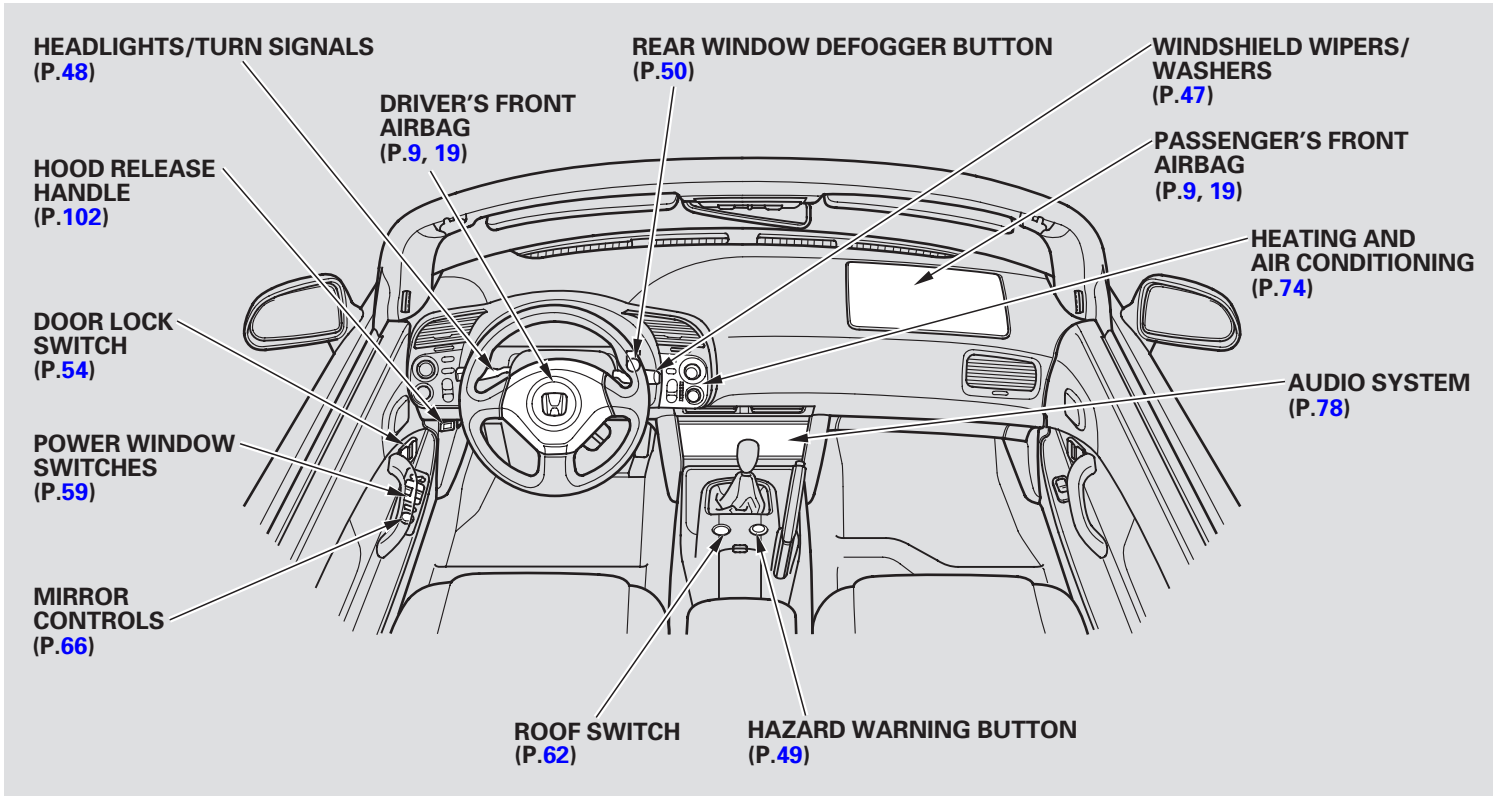

# Your Vehicle at a Glance

---

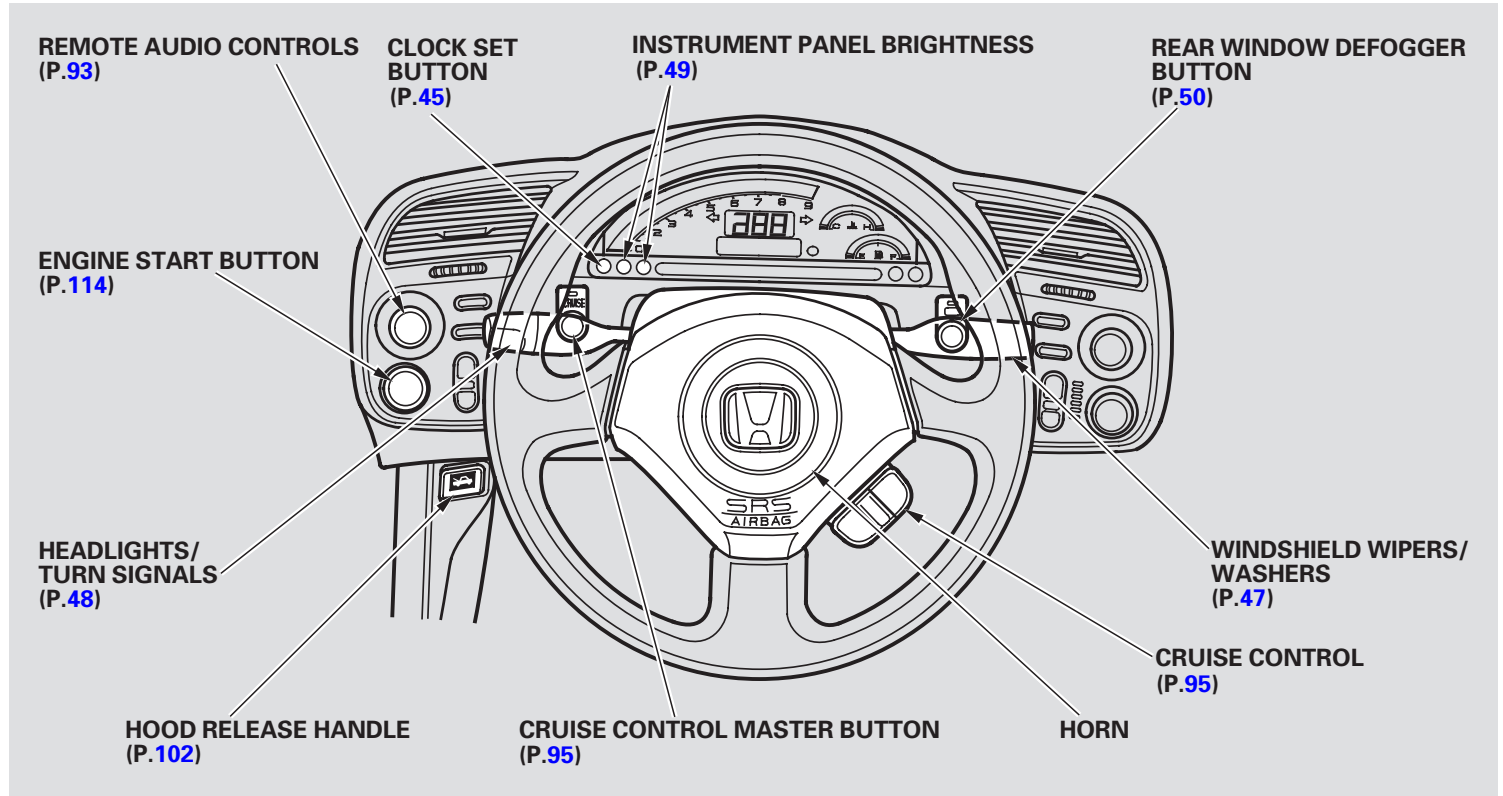

This section gives you important information about how to protect yourself and your passenger. It shows you how to use seat belts. It explains how your airbags work. And it tells you how to properly restrain children in your vehicle.

Important Safety Precautions .....	6
Your Vehicle's Safety Features.....	7
Seat Belts .....	8
Airbags.....	9
Protecting Adults and Teens.....	10
1. Close and Lock the Doors.....	10
2. Adjust the Seats .....	10
3. Adjust the Seat-Backs .....	11
4. Fasten and Position the Seat Belts.....	12
5. Maintain a Proper Sitting Position .....	13
Advice for Pregnant Women.....	14
Additional Safety Precautions....	15
Additional Information About	
Your Seat Belts .....	16
Seat Belt System Components...	16
Lap/Shoulder Belt.....	16
Automatic Seat Belt Tensioners.....	17
Seat Belt Maintenance.....	17
Additional Information About Your	
Airbags.....	19
Airbag System Components.....	19
How Your Front Airbags Work.....	19
How the SRS Indicator Works.....	21
Airbag Service.....	21
Additional Safety Precautions....	22
Protecting Children – General Guidelines.....	23
All Children Must Be Restrained .....	23
Your Vehicle is Not Recommended for Child Passengers .....	24
The Passenger's Airbag Poses Serious Risks.....	24
Additional Safety Precautions....	26
Protecting Small Children .....	27
Selecting a Child Seat.....	28
Installing a Child Seat .....	28
Protecting Larger Children .....	31
Checking Seat Belt Fit.....	31
Using a Booster Seat.....	32
When Can a Child Ride in This Vehicle .....	33
Additional Safety Precautions....	34
Carbon Monoxide Hazard .....	35
Safety Labels .....	36

## Important Safety Precautions

---

You'll find many safety recommendations throughout this section, and throughout this manual. The recommendations on this page are the ones we consider to be the most important.

### **Always Wear Your Seat Belt**

A seat belt is your best protection in all types of collisions. Airbags are designed to supplement seat belts, not replace them. So even though your vehicle is equipped with airbags, make sure you and your passenger always wear your seat belts, and wear them properly (see page [12](#) ).

### **Your Vehicle is Not Recommended for Child Passengers**

Since all children are safest in the back seat of a vehicle, and your vehicle does not have a back seat, we recommend that you do not carry a child passenger.

***Due to the passenger's airbag hazard, you should never carry an infant in a rear-facing child seat in this vehicle.***

If an older child must ride in this vehicle, follow all child safety instructions and warnings in this manual (see pages [23](#) – [34](#) ).

### **Be Aware of Airbag Hazards**

While airbags can save lives, they can cause serious or fatal injuries to occupants who sit too close to them, or are not properly restrained. Infants, young children, and short adults are at the greatest risk. Be sure to follow all instructions and warnings in this manual.

### **Don't Drink and Drive**

Alcohol and driving don't mix. Even one drink can reduce your ability to respond to changing conditions, and your reaction time gets worse with every additional drink. So don't drink and drive, and don't let your friends drink and drive, either.

### **Control Your Speed**

Excessive speed is a major factor in crash injuries and deaths. Generally, the higher the speed, the greater the risk, but serious injuries can also occur at lower speeds. Never drive faster than is safe for current conditions, regardless of the maximum speed posted.

### **Keep Your Vehicle in Safe Condition**

Having a tire blowout or a mechanical failure can be extremely hazardous. To reduce the possibility of such problems, check your tire pressures and condition frequently, and perform all regularly scheduled maintenance (see page [125](#) ).



# Your Vehicle's Safety Features

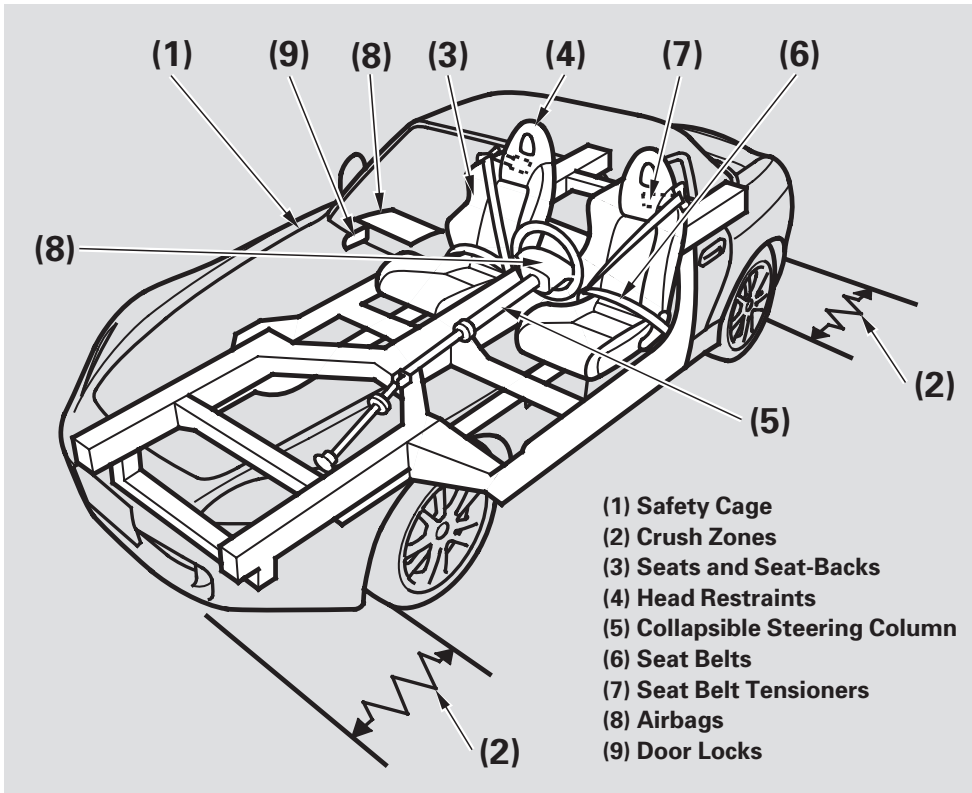

Your vehicle is equipped with many features that work together to protect you and your passenger during a crash.

Some features do not require any action on your part. These include a strong steel framework that forms a safety cage around the passenger compartment; front and rear crush zones, a collapsible steering column; and tensioners that tighten the seat belts in a crash.

However, you and your passenger can't take full advantage of these features unless you remain sitting in a proper position and ***always wear your seat belts***. In fact, some safety features can contribute to injuries if they are not used properly.

The following pages explain how you can take an active role in protecting yourself and your passenger.

# Your Vehicle's Safety Features

---

## Seat Belts

Your vehicle is equipped with seat belts in both seating positions.

Your seat belt system also includes an indicator on the instrument panel to remind you and your passenger to fasten your seat belts.

### *Why Wear Seat Belts*

Seat belts have proven to be the single most effective safety device for adults and larger children.

Not wearing a seat belt properly increases the chance of serious injury or death in a crash, even though your vehicle has airbags.

In addition, most states and all Canadian provinces require you to wear seat belts.

## **WARNING**

Not wearing a seat belt properly increases the chance of serious injury or death in a crash, even though your vehicle has airbags.

Be sure you and your passenger always wear seat belts and wear them properly.

When properly worn, seat belts:

- Keep you connected to the vehicle so you can take advantage of the vehicle's built-in safety features.
- Help protect you in almost every type of crash, including frontal, side, and rear impacts and rollovers.

- Help keep you from being thrown against the inside of the vehicle and against the other occupant.
- Keep you from being thrown out of the vehicle.
- Help keep you in a good position should the airbags ever deploy. A good position reduces the risk of injury from an inflating airbag and allows you to get the best advantage from the airbag.

Of course, seat belts cannot completely protect you in every crash. But in most cases, seat belts can reduce your risk of serious injury.

***What you should do:*** Always wear your seat belt, and make sure you wear it properly.

## Airbags

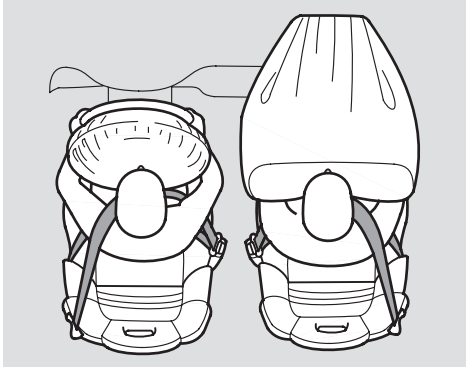

Your vehicle has a Supplemental Restraint System (SRS) with front airbags to help protect the heads and chests of the driver and a passenger during a moderate to severe frontal collision (see page 19 for more information on how your airbags work).

The most important things you need to know about your airbags are:

- ***Airbags do not replace seat belts.*** They are designed to supplement the seat belts.
- ***Front airbags offer no protection in side impacts, rear impacts, rollovers, or minor collisions.***
- ***Airbags can pose serious hazards.*** To do their job, airbags must inflate with tremendous force. So while airbags help save lives, they can cause minor injuries or more serious or even fatal injuries if occupants are not properly restrained or sitting properly.

***What you should do:*** Always wear your seat belt properly, and sit upright and as far back from the steering wheel as possible while allowing full control of the vehicle. A passenger should move the seat as far back from the dashboard as possible.

The rest of this section gives more detailed information about how you can maximize your safety.

Remember, however, that no safety system can prevent all injuries or deaths that can occur in a severe crash, even when seat belts are properly worn and the airbags deploy.

# Protecting Adults and Teens

## Introduction

The following pages provide instructions on how to properly protect the driver, an adult passenger or teenage child large enough and mature enough to drive or ride in your vehicle. See pages [23](#) – [34](#) for important guidelines on how to properly protect a small or larger child.

## 1. Close and Lock the Doors

After everyone has entered the vehicle, be sure the doors are closed and locked.



Your vehicle has door and trunk monitor indicators on the instrument panel to indicate when either door or the trunk is not tightly closed.

Locking the doors reduces the chance of someone being thrown out of the vehicle during a crash, and it helps prevent a passenger from accidentally opening a door and falling out.

Locking the doors also helps prevent an outsider from unexpectedly opening a door when you come to a stop.

See page [54](#) for how to lock the doors, and page [41](#) for how the door-open indicator works.

## 2. Adjust the Seats

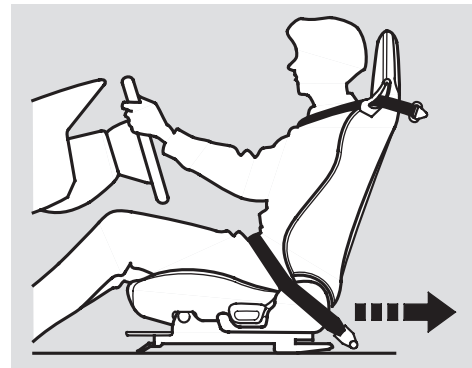

Adjust the driver's seat as far to the rear as possible while allowing you to maintain full control of the vehicle. Have a passenger adjust his or her seat as far to the rear as possible.

If you sit too close to the steering wheel or dashboard, you can be seriously injured by an inflating airbag, or by striking the steering wheel or dashboard.

The National Highway Traffic Safety Administration and Transport Canada recommend that drivers allow at least 10 inches (25 cm) between the center of the steering wheel and the chest.

If you cannot get far enough away from the steering wheel and still reach the controls, we recommend that you investigate whether some type of adaptive equipment may help.

Once your seat is adjusted correctly, rock it back and forth to make sure the seat is locked in position.

See page [58](#) for how to adjust the seats.

## **⚠ WARNING**

Sitting too close to a front airbag can result in serious injury or death if the front airbags inflate.

Always sit as far back from the front airbags as possible.

## **3. Adjust the Seat-Backs**

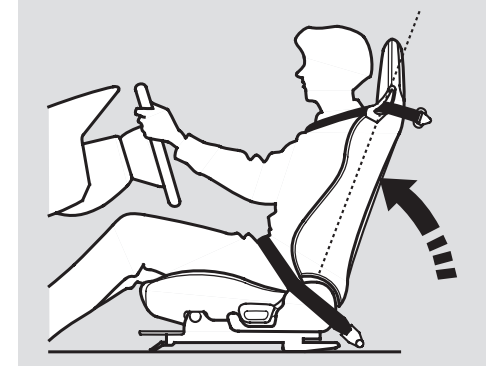

Adjust the driver's seat-back to a comfortable, upright position, leaving ample space between your chest and the airbag cover in the center of the steering wheel.

A passenger should also adjust their seat-back to a comfortable, upright position.

*CONTINUED*

## Protecting Adults and Teens

---

Reclining a seat-back so that the shoulder part of the belt no longer rests against the occupant's chest reduces the protective capability of the belt. It also increases the chance of sliding under the belt in a crash and being seriously injured. The farther a seat-back is reclined, the greater the risk of injury.

See page 58 for how to adjust the seat-backs.

### **⚠ WARNING**

Reclining the seat-back too far can result in serious injury or death in a crash.

Adjust the seat-back to an upright position, and sit well back in the seat.

### **4. Fasten and Position the Seat Belts**

Insert the latch plate into the buckle, then tug on the belt to make sure the belt is securely latched. Check that the belt is not twisted, because a twisted belt can cause serious injuries in a crash.



Position the lap part of the belt as low as possible across your hips, then pull up on the shoulder part of the belt so the lap part fits snugly. This lets your strong pelvic bones take the force of a crash and reduces the chance of internal injuries.

If necessary, pull up on the belt again to remove any slack, then check that the belt rests across the center of your chest and over your shoulder. This spreads the forces of a crash over the strongest bones in your upper body.

***Never place the shoulder portion of a lap/shoulder belt under your arm or behind your back.*** This could cause very serious injuries in a crash.

## **⚠ WARNING**

Improperly positioning the seat belts can cause serious injury or death in a crash.

Make sure all seat belts are properly positioned before driving.

If a seat belt does not seem to work properly, it may not protect the occupant in a crash.

***No one should sit in a seat with an inoperative seat belt.*** Using a seat belt that is not working properly can result in serious injury or death. Have your dealer check the belt as soon as possible.

See page 16 for additional information about your seat belts and how to take care of them.

## **5. Maintain a Proper Sitting Position**

After occupants have adjusted their seats and put on seat belts, it is very important that they continue to sit upright, well back in their seats, with their feet on the floor, until the vehicle is parked and the engine is off.

Sitting improperly can increase the chance of injury during a crash. For example, if an occupant slouches, lies down, turns sideways, sits forward, leans forward or sideways, or puts one or both feet up, the chance of injury during a crash is greatly increased.

CONTINUED

# Protecting Adults and Teens

---

In addition, an occupant who is out of position can be seriously or fatally injured in a crash by striking interior parts of the vehicle or being struck by an inflating front airbag.

## **⚠️ WARNING**

Sitting improperly or out of position can result in serious injury or death.

Always sit upright, well back in the seat, with your feet on the floor.

## **Advice for Pregnant Women**



If you are pregnant, the best way to protect yourself and your unborn child when driving or riding in a vehicle is to always wear a seat belt, and keep the lap part of the belt as low as possible across the hips.

When driving, remember to sit upright and adjust the seat as far back as possible while allowing full control of the vehicle. When riding as a passenger, adjust the seat as far back as possible.

This will reduce the risk of injuries to both you and your unborn child that can be caused by a crash or an inflating front airbag.

Each time you have a checkup, ask your doctor if it's okay for you to drive.



### Additional Safety Precautions

- ***Two people should never use the same seat belt.*** If they do, they could be very seriously injured in a crash.
- ***Do not put any accessories on seat belts.*** Devices intended to improve occupant comfort or reposition the shoulder part of a seat belt can reduce the protective capability of the belt and increase the chance of serious injury in a crash.
- ***Do not place hard or sharp objects between yourself and a front airbag.*** Carrying hard or sharp objects on your lap, or driving with a pipe or other sharp object in your mouth, can result in injuries if your front airbag inflates.
- ***Do not attach or place objects on the front airbag covers.*** Objects on the covers marked “SRS AIRBAG” could interfere with the proper operation of the airbags or be propelled inside the vehicle and hurt someone if the airbags inflate.
- ***Keep your hands and arms away from the airbag covers.*** If your hands or arms are close to an airbag cover, they could be injured if the airbag inflates.

## Additional Information About Your Seat Belts

---

### Seat Belt System Components

Your seat belt system includes lap/shoulder belts in both seating positions. These belts are equipped with automatic seat belt tensioners.



The seat belt system includes an indicator on the instrument panel and a beeper to remind you to fasten your seat belt.

If you turn the ignition switch to ON (II) before fastening your seat belt, the beeper will sound, and the indicator will flash. If you do not fasten your seat belt before the beeper stops, the indicator will stop flashing but remain on.

If you continue driving without fastening your seat belt, the beeper will sound and the indicator will flash again at regular intervals.

### Lap/Shoulder Belt

The lap and shoulder belt goes over your shoulder, across your chest, and across your hips.

To fasten the belt, insert the latch plate into the buckle, then tug on the belt to make sure the buckle is latched (see page [12](#) for how to properly position the belt).

To unlock the belt, push the red PRESS button on the buckle. Guide the belt across your body so that it retracts completely. After exiting the vehicle, be sure the belt is out of the way and will not get closed in the door.

Both seat belts have an emergency retractor. In normal driving, the retractor lets you move freely in your seat while it keeps some tension on the belt. During a collision or sudden stop, the retractor automatically locks the belt to help restrain your body.

The passenger's seat belt has an additional locking mechanism that must be activated to secure a forward-facing child seat (see page [29](#) ).

If the shoulder part of the belt is pulled all the way out, the locking mechanism will activate. The belt will retract, but it will not allow the passenger to move freely.

To deactivate the locking mechanism, unlatch the buckle and let the seat belt fully retract. To refasten the seat belt, pull it out only as far as needed.

## Additional Information About Your Seat Belts

### Automatic Seat Belt Tensioners



For added protection, the seat belts are equipped with automatic seat belt tensioners. When activated, the tensioners immediately tighten the belts to help hold the driver and a passenger in place.

The tensioners are designed to activate primarily in frontal collisions, and they should activate in any collision severe enough to cause airbag inflation.

However, the tensioners can be activated during a collision in which the front airbags do not deploy. In this case, the airbags would not be needed, but the additional restraint could be helpful.

When the tensioners are activated, the seat belts will remain tight until they are unbuckled in the normal manner.

### Seat Belt Maintenance

For safety, you should check the condition of your seat belts regularly.

Pull each belt out fully and look for frays, cuts, burns, and wear. Check that the latches work smoothly and the belts retract easily. Any belt that is not in good condition or not working properly will not provide good protection and should be replaced as soon as possible.

Honda provides a lifetime warranty on seat belts for U.S. models. See your *Honda Warranty Information* booklet for details.

If a seat belt is worn during a crash, it must be replaced by your dealer. A belt that has been worn during a crash may not provide the same level of protection in a subsequent crash.

*CONTINUED*

## Additional Information About Your Seat Belts

---

The dealer should also inspect the anchors for damage and replace them if needed. If the automatic seat belt tensioners activate during a crash, they must be replaced.

For information on how to clean your seat belts, see page [145](#) .

### **WARNING**

Not checking or maintaining seat belts can result in serious injury or death if the seat belts do not work properly when needed.

Check your seat belts regularly and have any problem corrected as soon as possible.

## Additional Information About Your Airbags

### Airbag System Components

Your airbag system includes:

- Two SRS (Supplemental Restraint System) front airbags. The driver's airbag is stored in the center of the steering wheel; the passenger's airbag is stored in the dashboard. Both are marked "SRS AIRBAG."
- Automatic seat belt tensioners (see page 17 ).
- Sensors that can detect a moderate to severe frontal collision.
- A sophisticated electronic system that continually monitors and records information about the sensors, the control unit, and the airbag activators when the ignition switch is in the ON (II) position.

- An indicator on the instrument panel that alerts you to a possible problem with your airbags, sensors, or seat belt tensioners (see page 21 ).
- Emergency backup power in case your vehicle's electrical system is disconnected in a crash.

### How Your Front Airbags Work

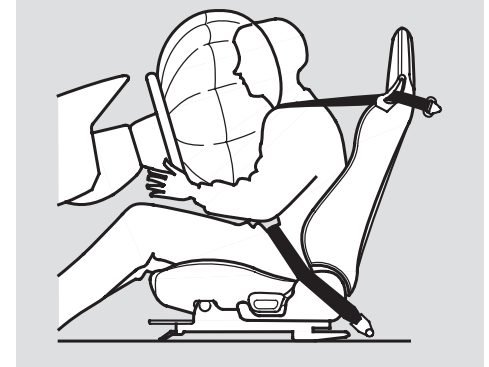

If you ever have a moderate to severe frontal collision, sensors will detect the vehicle's rapid deceleration.

If the rate of deceleration is high enough, the control unit will instantly inflate the driver's and passenger's front airbags.

*CONTINUED*

## Additional Information About Your Airbags

---

During a frontal crash, your seat belt restrains your lower body and torso, and the airbag helps protect your head and chest.

Although both airbags normally inflate within a split second of each other, it is possible for only one airbag to deploy.

This can happen if the severity of a collision is at the margin, or threshold, that determines whether or not the airbags will deploy. In such cases, the seat belt will provide sufficient protection, and the supplemental protection offered by the airbag would be minimal.

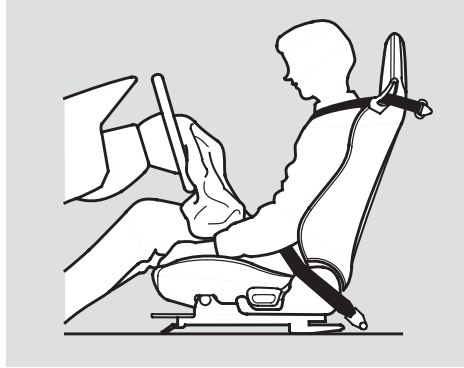

After inflating, the front airbags will immediately deflate, so they won't interfere with the driver's visibility, or the ability to steer or operate other controls.

The total time for inflation and deflation is one-tenth of a second, so fast that most occupants are not aware that the airbags deployed until they see them lying in their laps.

After a crash, you may see what looks like smoke. This is actually powder from the airbag's surface. Although the powder is not harmful, people with respiratory problems may experience some temporary discomfort. If this occurs, get out of the vehicle as soon as it is safe to do so.

### How the SRS Indicator Works



The SRS indicator alerts you to a potential problem with your airbags or seat belt tensioners (see page 17).

When you turn the ignition switch to ON (II), this indicator will come on briefly then go out. This tells you the system is working properly.

If the indicator comes on at any other time, or does not come on at all, you should have the system checked by your dealer. For example:

- If the SRS indicator does not come on after you turn the ignition switch to ON (II).
- If the indicator stays on after the engine starts.
- If the indicator comes on or flashes on and off while you drive.

If you see any of these indications, the airbags and seat belt tensioners may not work properly when you need them.

### **WARNING**

Ignoring the SRS indicator can result in serious injury or death if the airbag systems or tensioners do not work properly.

Have your vehicle checked by a dealer as soon as possible if the SRS indicator alerts you to a possible problem.

### Airbag Service

Your airbag system is virtually maintenance-free, and there are no parts you can safely service. However, you must have your vehicle serviced if:

- ***An airbag ever inflates.*** Any airbag that has deployed must be replaced, along with the control unit and seat belt tensioner. Do not try to remove or replace any airbag by yourself. This must be done by your dealer or a knowledgeable body shop.
- ***The SRS indicator alerts you to a problem.*** Take your vehicle to an authorized dealer as soon as possible. If you ignore this indication, your airbags may not operate properly.

## Additional Information About Your Airbags

---

### Additional Safety Precautions

- ***Do not attempt to deactivate your airbags.*** Together, airbags and seat belts provide the best protection.
- ***Do not tamper with airbag components or wiring for any reason.*** Tampering could cause the airbags to deploy, possibly causing very serious injury.



Children depend on adults to protect them. However, despite their best intentions, many adults do not know how to *properly* protect child passengers.

If you ever need to drive with a child in your vehicle, be sure to read this section. It begins with important general guidelines, then presents special information for infants, small children and larger children.

## **All Children Must Be Restrained**

Each year, many children are injured or killed in vehicle crashes because they are either unrestrained or not properly restrained. In fact, vehicle accidents are the number one cause of the death of children ages 12 and under.

To reduce the number of child deaths and injuries, every state and Canadian province requires that infants and children be properly restrained when they ride in a vehicle.

***Any child who is too small to wear a seat belt must be restrained in an approved child seat that is properly secured to the vehicle*** (see pages 28 – 30).

***A larger child must be restrained with a lap/shoulder belt and ride on a booster seat until the seat belt fits him or her properly*** (see pages 31 – 34).

## **⚠ WARNING**

Children who are unrestrained or improperly restrained can be seriously injured or killed in a crash.

Any child too small for a seat belt should be properly restrained in a child seat. A larger child should be properly restrained with a seat belt and use a booster seat if necessary.

## Protecting Children – General Guidelines

---

### **Your Vehicle is Not Recommended for Child Passengers**

The National Highway Traffic Safety Administration and Transport Canada recommend that all children age 12 and under be properly restrained in a back seat.

Since this vehicle does not have a back seat, we strongly recommend that you do not carry any child who is not large enough or mature enough to ride in front (see page [33](#)).

### **The Passenger's Front Airbag Poses Serious Risks**

Front airbags have been designed to help protect adults in a moderate to severe frontal collision. To do this, the passenger's airbag is quite large, and it can inflate with enough force to cause very serious injuries.

#### ***Infants***

***Never put a rear-facing child seat in this vehicle.*** If the airbag inflates, it can hit the back of the child seat with enough force to kill or very seriously injure an infant.

#### ***Small Children***

***Placing a forward-facing child seat in the passenger's seat can be hazardous.*** If the vehicle seat is too far forward, or the child's head is thrown forward during a collision, an inflating front airbag can strike the child with enough force to kill or very seriously injure a small child.

#### ***Larger Children***

***Children who have outgrown child seats are also at risk of being injured or killed by an inflating passenger's front airbag.*** If a larger child must ride in this vehicle, see page [33](#) for important guidelines on how to decide when a child is ready to ride in front and how to properly protect the child.

# Protecting Children – General Guidelines

To remind you of the passenger's airbag hazards, your vehicle has warning labels on the dashboard (U.S. models) and on the driver's and passenger's visors. Please read and follow the instructions on these labels.

## *U.S. Models* Sun Visor

 <b>WARNING</b>	
	<b>DEATH or SERIOUS INJURY</b> can occur <ul style="list-style-type: none"><li>• Children 12 and under can be killed by the air bag</li><li>• NEVER put a rear-facing child seat in the front</li><li>• Sit as far back as possible from the air bag</li><li>• ALWAYS use SEAT BELTS and CHILD RESTRAINTS</li></ul>

## *Canadian Models* Sun Visor

<b>CAUTION</b> TO AVOID SERIOUS INJURY: <ul style="list-style-type: none"><li>• FOR MAXIMUM SAFETY PROTECTION IN ALL TYPES OF CRASHES, YOU MUST ALWAYS WEAR YOUR SAFETY BELT.</li><li>• DO NOT INSTALL REARWARD-FACING CHILD SEATS IN ANY FRONT PASSENGER SEAT POSITION.</li><li>• DO NOT SIT OR LEAN UNNECESSARILY CLOSE TO THE AIR BAG.</li><li>• DO NOT PLACE ANY OBJECTS OVER THE AIR BAG OR BETWEEN THE AIR BAG AND YOURSELF.</li><li>• SEE THE OWNER'S MANUAL FOR FURTHER INFORMATION AND EXPLANATIONS.</li></ul>	<b>PRÉCAUTIONS:</b> POUR ÉVITER DES BLESSURES GRAVES: <ul style="list-style-type: none"><li>• POUR PROFITER D'UNE PROTECTION MAXIMALE LORS D'UNE COLLISION, BOUCLEZ TOUJOURS VOTRE CEINTURE DE SÉCURITÉ.</li><li>• N'INSTALLEZ JAMAIS UN SIÈGE POUR ENFANTS FAISANT FACE À L'ARRIÈRE SUR LE SIÈGE DU PASSAGER AVANT.</li><li>• NE VOUS APPUYEZ PAS ET NE VOUS ASSOYEZ PAS PRÈS DU COUSSIN GONFLABLE.</li><li>• NE DÉPOSEZ AUCUN OBJET SUR LE COUSSIN GONFLABLE OU ENTRE LE COUSSIN GONFLABLE ET VOUS.</li><li>• LISEZ LE GUIDE UTILISATEUR POUR DE PLUS AMPLES RENSEIGNEMENTS.</li></ul>
--	---

## Dashboard

 <b>WARNING</b>
<b>Children Can Be KILLED or INJURED by Passenger Air Bag</b>
• Make sure all children use seat belts or child seats.
To be removed by owner only.

## Protecting Children – General Guidelines

---

### Additional Safety Precautions

- **Never hold a small child on your lap.** If you are not wearing a seat belt in crash, you could be thrown forward and crush the child against the dashboard. If you are wearing a seat belt, the child can be torn from your arms and be seriously hurt or killed.
- **Never put a seat belt over yourself and a child.** During a crash, the belt could press deep into the child and cause serious or fatal injuries.
- **Never let two children use the same seat belt.** If they do, they could be very seriously injured in a crash.

- **Do not leave children alone in a vehicle.** Leaving children without adult supervision is illegal in most states and Canadian provinces, and can be very hazardous.

For example, a small child left in a vehicle on a hot day can die from heatstroke. A child left alone with the key in the ignition switch can accidentally set the vehicle in motion, possibly injuring themselves or others.

- **Lock both doors and the trunk when your vehicle is not in use.** Children who play in vehicles can accidentally get trapped inside. Teach your children not to play in or around vehicles. Know how to operate the emergency trunk opener and decide if your children should be shown how to use this feature (see page [55](#)).

- **Keep vehicle keys and remote transmitters out of the reach of children.** Even very young children learn how to unlock vehicle doors, turn on the ignition switch, and open the trunk, which can lead to accidental injury or death.

Because an inflating airbag can seriously injure or kill small children, we recommend that you do not carry a small child as a passenger in this vehicle.

If you decide to transport a small child in this vehicle, be sure to move the passenger seat as far to the rear as possible, and follow the instructions and guidelines in the following pages.



A child who is at least one year old and who fits within the child seat maker's weight and height limits, should be restrained in a forward-facing, upright child seat.

Of the different seats available, we recommend those that have a five-point harness system as shown.

We also recommend that a small child uses the child seat as long as possible, until the child reaches the weight or height limit for the seat.

### **⚠ WARNING**

Placing a forward-facing child seat in the passenger's seat can result in serious injury or death if the airbag inflates.

If you must place a forward-facing child seat in the passenger's seat, move the vehicle seat as far back as possible and properly restrain the child.

# Selecting a Child Seat, Installing a Child Seat

---

## Selecting a Child Seat

To provide proper protection, a child seat should meet three requirements:

- 1. The child seat should meet U.S. or Canadian Motor Vehicle Safety Standard 213.** Look for FMVSS 213 or CMVSS 213 on the box.
- 2. The child seat should be of the proper type and size to fit the child.**
- 3. The child seat should fit the passenger's seat.**

Before purchasing a child seat, or using a previously purchased one, we recommend that you test the seat to make sure it fits properly in the passenger's seat.

## Installing a Child Seat

After selecting a proper child seat, there are three main steps in installing a child seat:

- 1. Properly secure the child seat to the vehicle.** All child seats must be secured to the vehicle with the lap part of a lap/shoulder belt. A child whose seat is not properly secured to the vehicle can be endangered in a crash.
- 2. Make sure the child seat is firmly secured.** After installing a child seat, push and pull the seat forward and from side to side to verify that it is secure.

A child seat secured with a seat belt should be installed as firmly as possible. However, it does not need to be “rock solid.” Some side-to-side movement can be expected and should not reduce the child seat's effectiveness.

If the child seat is not secure, use a different style of child seat that can be firmly secured.

### **3. Secure the child in the child seat.**

Make sure the child is properly strapped in the child seat according to the child seat maker's instructions. A child who is not properly secured in a child seat can be seriously injured in a crash.

The following pages provide guidelines on how to properly install a forward-facing child seat.

## Installing a Child Seat

In this vehicle, a child seat must be secured to the vehicle with the lap part of the lap/shoulder belt. In addition, the passenger's lap/shoulder belt has a locking mechanism that must be activated to secure a child seat.

1. Move the vehicle seat to the rear-most position. Moving the seat as far back as possible reduces the chance of a child being injured or killed if the passenger's airbag inflates.

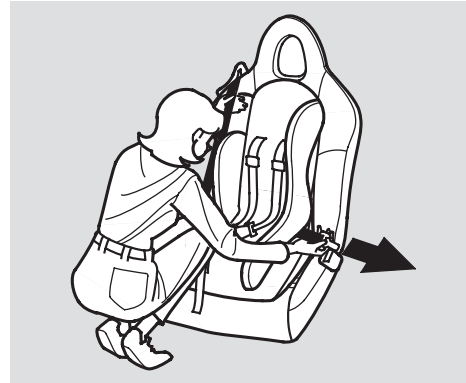

2. With the child seat in position, route the belt through the child seat according to the seat maker's instructions, then insert the latch plate into the buckle.
3. To activate the lockable retractor, slowly pull the shoulder part of the belt all the way out until it stops, then let the belt feed back into the retractor.

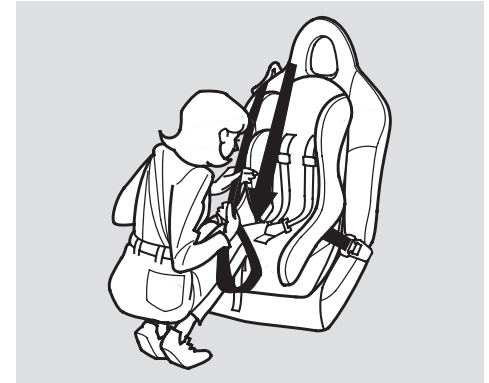

4. After the belt has retracted, tug on it. If the belt is locked, you will not be able to pull it out. If you can pull the belt out, it is not locked and you will need to repeat these steps.

CONTINUED

## Installing a Child Seat

---



5. After confirming that the belt is locked, grab the shoulder part of the belt near the buckle and pull up to remove any slack from the lap part of the belt. Remember, if the lap part of the belt is not tight, the child seat will not be secure.

To remove slack, it may help to put weight on the child seat, or push on the back of the seat while pulling up on the belt.

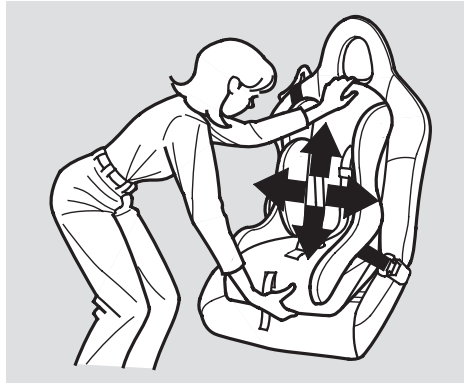

6. Push and pull the child seat forward and from side to side to verify that it is secure enough to stay upright during normal driving maneuvers. If the child seat is not secure, unlatch the belt, allow it to retract fully, then repeat these steps.

To deactivate the locking mechanism and remove a child seat, unlatch the buckle, unrout the seat belt, and let the belt fully retract.



When a child reaches the recommended weight or height limit for a forward-facing child seat, the child should sit in a back seat on a booster seat and wear a lap/shoulder belt.

Since this vehicle does not have a back seat, we recommend that you do not carry a larger child, age 12 or under, as a passenger.

However, the following pages provide guidelines to help you decide when a given child may ride in this vehicle, and how to properly protect the child.

## **⚠ WARNING**

Allowing a larger child age 12 or under to ride in the vehicle can result in injury or death if the passenger's front airbag inflates.

If a larger child must ride in the vehicle, move the vehicle seat as far back as possible, use a booster seat if needed, have the child sit up properly and wear the seat belt properly.

## Checking Seat Belt Fit



To determine if a lap/shoulder belt properly fits a child, have the child put on the seat belt, then ask yourself:

1. Does the child sit all the way back against the seat?
2. Do the child's knees bend comfortably over the edge of the seat?

*CONTINUED*

## Protecting Larger Children

---

3. Does the shoulder belt cross between the child's neck and arm?
4. Is the lap part of the belt as low as possible, touching the child's thighs?
5. Will the child be able to stay seated like this for the whole trip?

If you answer yes to all these questions, the child is ready to wear the lap/shoulder belt correctly. If you answer no to any question, the child needs to ride on a booster seat.

### Using a Booster Seat



A child who has outgrown a forward-facing child seat should use a booster seat until the lap/shoulder belt fits them properly without the booster.

Some states and Canadian provinces also require children to use a booster seat until they reach a given age or weight (e.g., 6 years or 60 lbs). Be sure to check current laws in the states or provinces where you intend

to drive.

Booster seats can be high-back or low-back. Whichever style you select, make sure the booster meets federal safety standards and that you follow the booster seat maker's instructions.

If a child who uses a booster seat rides in this vehicle, move the vehicle seat as far to the rear as possible, and be sure the child is wearing the seat belt properly.

A child may continue using a booster seat until the tops of their ears are even with the top of the vehicle's or booster's seat-back. A child of this height should be tall enough to use the lap/shoulder belt without a booster seat.

### When Can a Larger Child Ride in This Vehicle

As noted earlier, the National Highway Traffic Safety Administration and Transport Canada recommend that all children age 12 and under ride properly restrained in a back seat.

If the passenger's front airbag inflates in a moderate to severe frontal collision, the airbag can cause serious injuries to a child who is unrestrained, improperly restrained, sitting too close to the airbag, or out of position.

Of course, children vary widely. And while age may be one indicator of when a child can safely ride in this vehicle. There are other important factors you should consider.

### *Physical Size*

Physically, a child must be large enough for the lap/shoulder belt to properly fit (see page 31). If the seat belt does not fit properly, with or without the child sitting on a booster, the child should not sit in this vehicle.

### *Maturity*

To safely ride in this vehicle, a child must be able to follow the rules, including sitting properly, and wearing the seat belt properly throughout ride.

If you decide that a child can safely ride in this vehicle, be sure to:

- Carefully read the owner's manual, and make sure you understand all seat belt instructions and all safety information.
- Move the vehicle seat to the rear-most position.
- Have the child sit up straight, back against the seat, and feet on or near the floor.
- Check that the child's seat belt is properly and securely positioned.
- Supervise the child. Even mature children sometimes need to be reminded to fasten the seat belts or sit properly.

## Protecting Larger Children

---

### **Additional Safety Precautions**

***Do not let a child wear a seat belt across the neck.*** This could result in serious neck injuries during a crash.

***Do not let a child put the shoulder part of a seat belt behind the back or under the arm.*** This could cause very serious injuries during a crash. It also increases the chance that the child will slide under the belt in a crash and be injured.

***Two children should never use the same seat belt.*** If they do, they could be very seriously injured in a crash.

***Do not put any accessories on a seat belt.*** Devices intended to improve a child's comfort or reposition the shoulder part of a seat belt can make the belt less effective and increase the chance of serious injury in a crash.

Your vehicle's exhaust contains carbon monoxide gas. You should have no problem with carbon monoxide entering the vehicle in normal driving if you maintain your vehicle properly.

Have the exhaust system inspected for leaks whenever:

- The vehicle is raised for an oil change.
- You notice a change in the sound of the exhaust.
- The vehicle was in an accident that may have damaged the underside.

## **WARNING**

Carbon monoxide gas is toxic. Breathing it can cause unconsciousness and even kill you.

Avoid any enclosed areas or activities that expose you to carbon monoxide.

High levels of carbon monoxide can collect rapidly in enclosed areas, such as a garage. Do not run the engine with the garage door closed. Even with the door open, run the engine only long enough to move the vehicle out of the garage.

With the trunk open, airflow can pull exhaust gas into your vehicle's interior and create a hazardous condition. If you must drive with the trunk open, open all the windows, and set the heating and cooling system as shown below.

If you must sit in your parked vehicle with the engine running, even in an unconfined area, adjust the heating and cooling system as follows:

1. Select the fresh air mode.
2. Select the  mode.
3. Set the fan speed to high.
4. Set the temperature control to a comfortable setting.

# Safety Labels

These labels are in the locations shown. They warn you of potential hazards that could cause serious injury. Read these labels carefully.

If a label comes off or becomes hard to read (except for the U.S. dashboard label which may be removed by the owner), contact your dealer for a replacement.

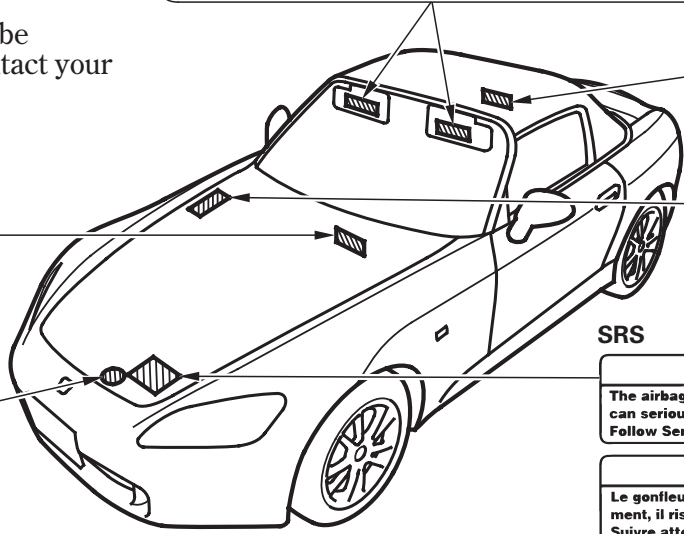

## SUN VISOR

U.S. models

**WARNING**

DEATH or SERIOUS INJURY can occur

- Children 12 and under can be killed by the air bag
- NEVER put a restraining child seat in the front
- Sit as far back as possible from the air bag
- ALWAYS use SEAT BELTS and CHILD RESTRAINTS

Canadian models

**CAUTION**  
TO AVOID SERIOUS INJURY

- FOR MAXIMUM SAFETY PROTECTION IN ALL TYPES OF CRASHES, YOU MUST ALWAYS WEAR YOUR BELT
- DO NOT PUT CHILDREN OR PASSENGERS UNDER 12 YEARS OF AGE IN THE FRONT SEAT
- DO NOT PUT CHILDREN OR PASSENGERS UNDER 12 YEARS OF AGE IN THE FRONT SEAT
- DO NOT PLACE ANY OBJECTS OVER THE AIR BAGS BEHIND THE SEAT
- SEE THE OWNER'S MANUAL FOR FURTHER INFORMATION AND PRECAUTIONS.

**PRECAUTIONS:**

- DO NOT COVER THE BLESSURES CRASHES
- DO NOT COVER THE PROTECTION
- DO NOT COVER THE PROTECTION
- DO NOT COVER THE PROTECTION
- DO NOT COVER THE PROTECTION
- DO NOT COVER THE PROTECTION
- DO NOT COVER THE PROTECTION
- DO NOT COVER THE PROTECTION
- DO NOT COVER THE PROTECTION
- DO NOT COVER THE PROTECTION

## DASHBOARD

U.S. models only

**WARNING**

Children Can Be **KILLED** or **INJURED** by Passenger Air Bag

- Make sure all children use seat belts or child seats.
- To be removed by owner only.

## SEAT BELT TENSIONER

<b>WARNING</b>	<b>ATTENTION</b>
EXPLOSIVE MATERIALS INSIDE	MATERIALS EXPLOSE ET S'ENTOUVENT
KEEP AWAY FROM OPEN FLAMES AND CIGARETTES. DO NOT SMOKING NEAR THE SEAT BELT TENSIONER.	ÉLOIGNER DES FLAMMES OU DES CIGARETTES ALLUMÉES. NE PAS FUMER À PROXIMITÉ DU TENSEUR DE CEINTURE.

## BATTERY

**DANGER**

**EXPLOSIVE GASES** Keep sparks, flame and cigarettes away. Provide adequate ventilation when charging or using batteries in an enclosed space.

**CHEMICAL HAZARD** Contains sulfuric acid. Contact with skin, even through clothing, may cause severe burns. Wear a face shield and protective clothing. If electrolyte gets into your eyes, accidently splash thoroughly with water for at least 15 minutes and call a physician immediately.

**POISON** Antacid: EXTERNAL-flush with water. INTERNAL-drink large quantities of water to mix, then follow with milk or magnesium hydroxide.

**KEEP OUT OF REACH OF CHILDREN**

## RADIATOR

**DANGER**  
**WARNING**  
危険

- ▶ NEVER OPEN WHEN HOT. Hot coolant will scald you.
- ▶ N'ouvrez pas quand chaud.
- ▶ NICHT BEI HEISSEM MOTOR ÖFFNEN.
- ▶ 熱い時あけないで下さい。
- ▶ 高温時、請勿打井

## SRS

**WARNING**

The airbag inflator is explosive and, if accidentally deployed, can seriously hurt you.

Follow Service Manual instructions carefully.

**ATTENTION**

Le gonfleur SRS est explosible, et s'il se déploie accidentellement, il risque de provoquer des blessures graves ou de tuer.

Suivre attentivement les instructions du manuel d'entretien.

This section gives information about the controls and displays that contribute to the daily operation of your vehicle. All the essential controls are within easy reach.

Control Locations .....	38	Power Windows .....	59
Instrument Panel .....	39	Convertible Top .....	61
Instrument Panel Indicators.....	40	Mirrors.....	66
Gauges .....	44	Parking Brake .....	67
Odometer.....	44	Interior Convenience Items.....	68
Trip meter.....	44	Beverage Holder.....	69
Select Button.....	44	Accessory Power Socket .....	69
Fuel Gauge .....	45	Console Compartments .....	69
Temperature Gauge .....	45	Audio Panel .....	70
Clock .....	45	Interior Light.....	71
Controls Near the Steering			
Wheel .....	46		
Windshield Wipers and			
Washers .....	47		
Turn Signal and Headlights.....	48		
Instrument Panel Brightness .....	49		
Hazard Warning Button.....	49		
Rear Window Defogger .....	50		
Keys and Locks.....	51		
Immobilizer System.....	52		
Ignition Switch .....	53		
Power Door Locks.....	54		
Trunk.....	54		
Emergency Trunk Opener .....	55		
Remote Transmitter.....	56		
Seats .....	58		

# Control Locations

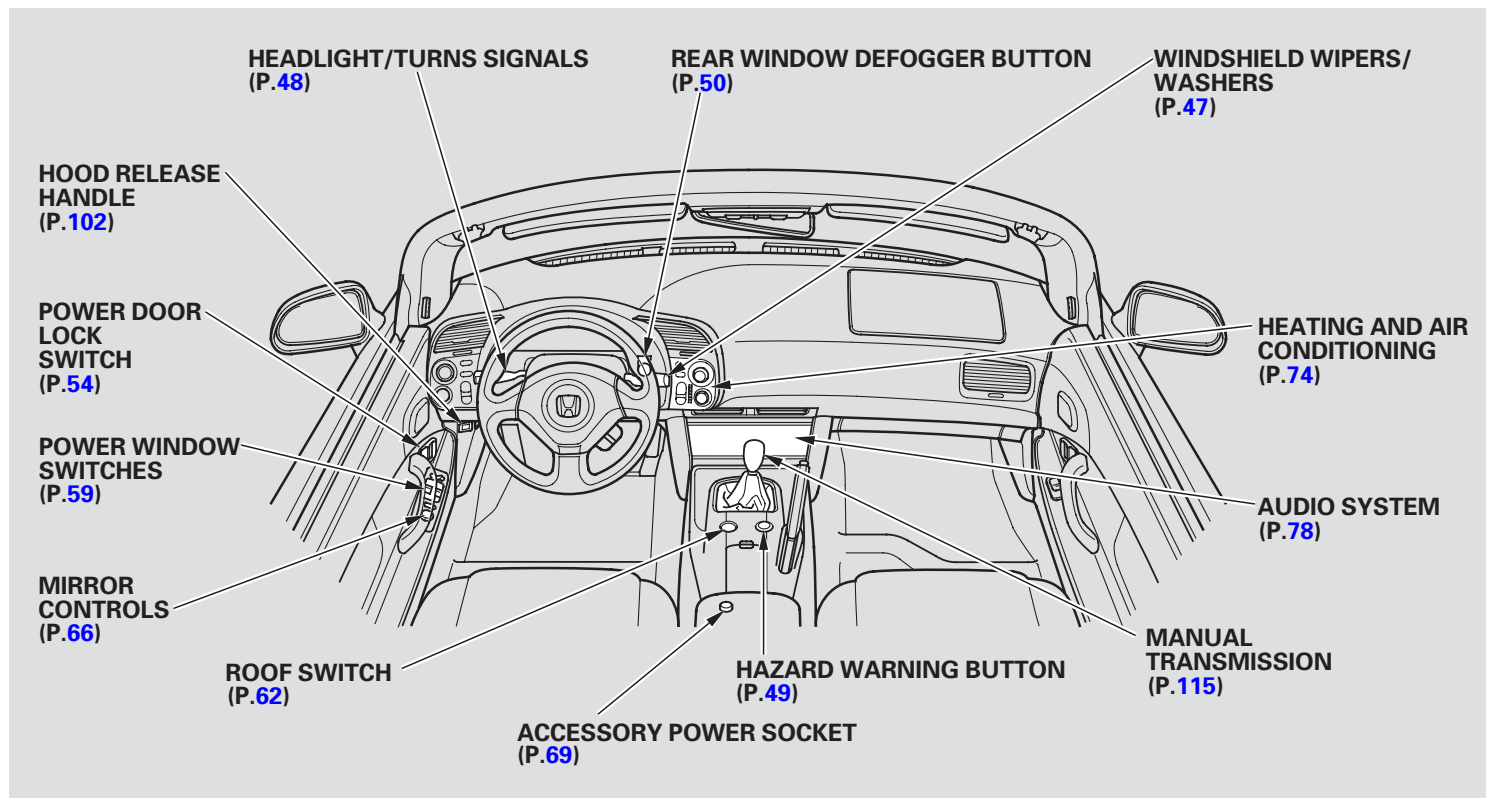



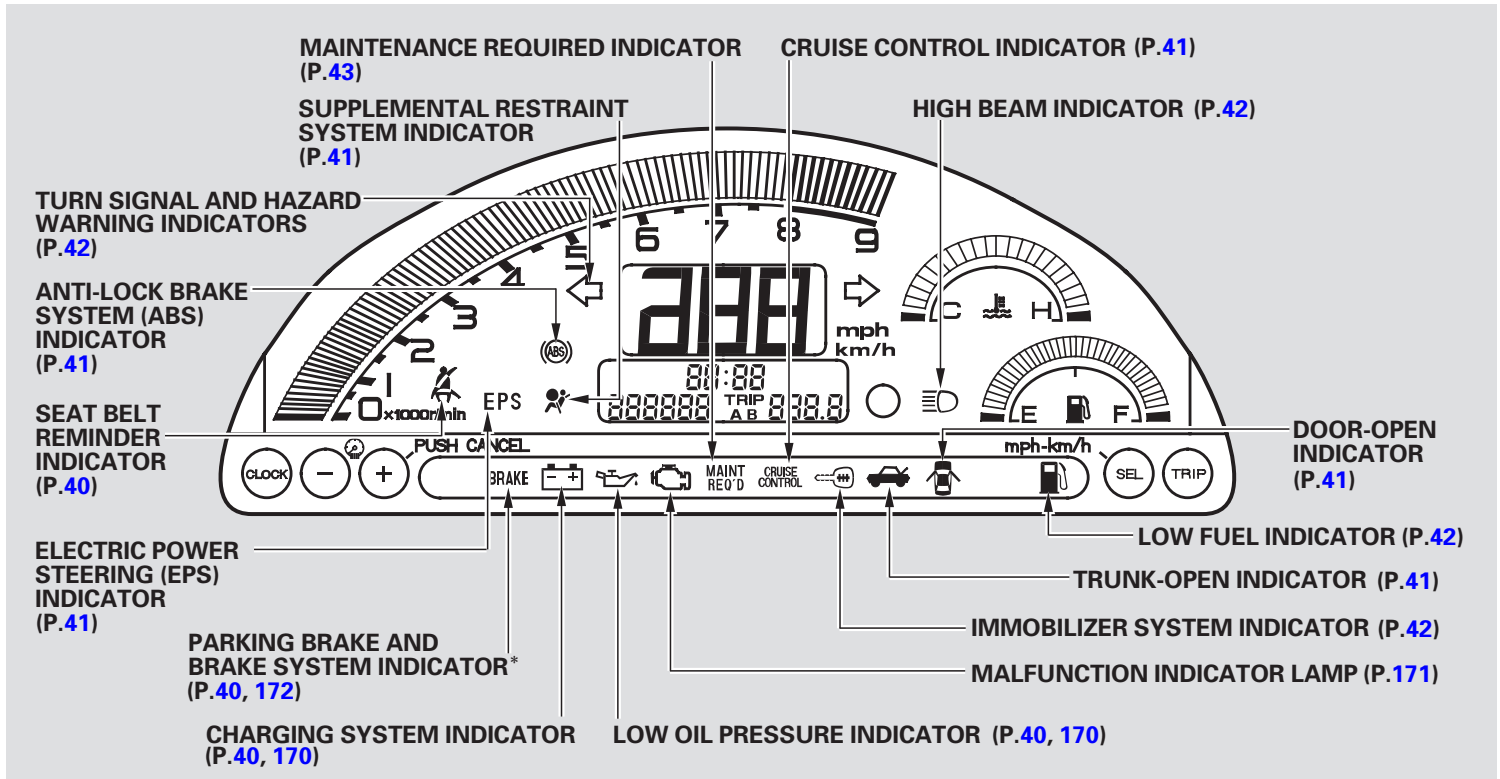

\* The U.S. instrument panel is shown. Differences for the Canadian models are noted in the text.

## Instrument Panel Indicators

---

The instrument panel has many indicators to give you important information about your vehicle.



### Seat Belt Reminder Indicator

This indicator comes on when you turn the ignition switch to ON (II). It reminds you and your passenger to fasten your seat belts. A beeper also sounds if you have not fastened your seat belt.

If you turn the ignition switch to ON (II) before fastening your seat belt, the beeper sounds and the indicator flashes. If you do not fasten your seat belt before the beeper stops, the indicator stops flashing but remains on.

If you continue driving without fastening your seat belt, the beeper sounds and the indicator flashes again at regular intervals.



### Low Oil Pressure Indicator

The engine can be severely damaged if this indicator flashes or stays on when the engine is running. For more information, see page [170](#).



### Charging System Indicator

If this indicator comes on when the engine is running, the battery is not being charged. For more information, see page [170](#).

### U.S. Canada Parking Brake and Brake System Indicator

This indicator has two functions:

1. It comes on when you turn the ignition switch to ON (II). It is a reminder to check the parking brake. A beeper sounds if you try to drive with the parking brake not fully released. Driving with the parking brake not fully released can damage the brakes and tires.
2. If it remains lit after you fully release the parking brake while the engine is running, or if it comes on while driving, there could be a problem with the brake system. For more information, see page [172](#).



## Supplemental Restraint System Indicator

This indicator comes on when you turn the ignition switch to ON (II). If it comes on at any other time, it indicates a potential problem with your front airbags or automatic seat belt tensioners. For more information, see page [21](#).



## Anti-lock Brake System (ABS) Indicator

This indicator normally comes on for a few seconds when you turn the ignition switch to ON (II), and when you push the START button. If it comes on at any other time, there is a problem with the ABS. If this happens, have your vehicle checked at a dealer. With this indicator on, your vehicle still has normal braking ability but no anti-lock function. For more information, see page [119](#).



## Malfunction Indicator Lamp

See page [171](#).



## Trunk-open Indicator

This indicator comes on if the trunk lid is not closed tightly.



## Door-open Indicator

This indicator comes on if either door is not closed tightly.



## Cruise Control Indicator

This indicator comes on when you set the cruise control. See page [95](#) for information on operating the cruise control.



## Electric Power Steering (EPS) Indicator

This indicator normally comes on when you turn the ignition switch to ON (II) and goes off after the engine starts. If it comes on at any other time, there is a problem in the Electric Power Steering system. If this happens, stop the vehicle in a safe place, and turn off the engine. Reset the system by restarting the engine, and watch the EPS indicator. If it does not go off, or comes back on again while driving, take the vehicle to your dealer to have it checked. With the indicator on, the EPS is turned off, making the vehicle harder to steer.

## Instrument Panel Indicators

---



### Turn Signal and Hazard Warning Indicators

The left or right turn signal indicator blinks when you signal a lane change or turn. If the indicator does not blink or blinks rapidly, it usually means one of the turn signal bulbs is burned out (see page [142](#) ). Replace the bulb as soon as possible, since other drivers cannot see that you are signaling.

When you press the Hazard Warning button, both turn signal indicators blink. All turn signals on the outside of the vehicle should flash.



### High Beam Indicator

This indicator comes on with the high beam headlights. For more information, see page [48](#) .



### “Daytime Running Lights” Indicator

*Canadian models only*

This indicator comes on when you turn the ignition switch to ON (II) with the headlight switch off and the parking brake set. It should go off if you turn on the headlights or release the parking brake. If it comes on at any other time, it means there is a problem with the DRL. There may also be a problem with the high beam headlights.



### Immobilizer System Indicator

This indicator comes on for a few seconds when you turn the ignition switch to ON (II). It will then go off if you have inserted a properly-coded ignition key. If it is not a properly-coded key, the indicator will blink, and the engine will not start (see page [52](#) ).

This indicator also blinks several times when you turn the ignition switch from ON (II) to ACCESSORY (I) or LOCK (0).



### Low Fuel Indicator

This indicator comes on as a reminder that you must refuel soon.

**MAINT  
REQ'D**

## Maintenance Required Indicator

This indicator reminds you that it is time to take your vehicle in for scheduled maintenance.

Refer to the Maintenance Schedules for Normal and Severe Driving Conditions on pages [125](#) and [126](#).

When the distance driven since the last scheduled maintenance reaches 6,000 miles (9,600 km), the indicator starts blinking. If you exceed 7,500 miles (12,000 km), the indicator stays on.

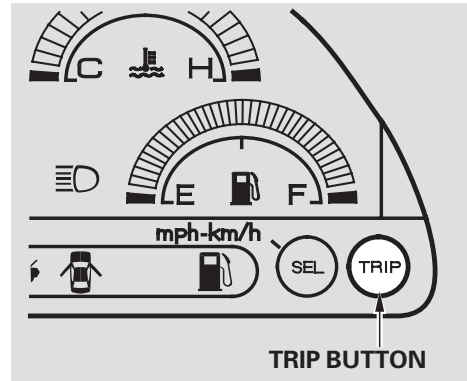

Your dealer will reset this indicator after completing the scheduled maintenance. If this maintenance is done by someone other than your dealer, reset the indicator as follows.

1. Turn off the engine.
2. Press and hold the TRIP button, then turn the ignition switch to ON (II).

3. Hold the button until the indicator goes off.

# Gauges

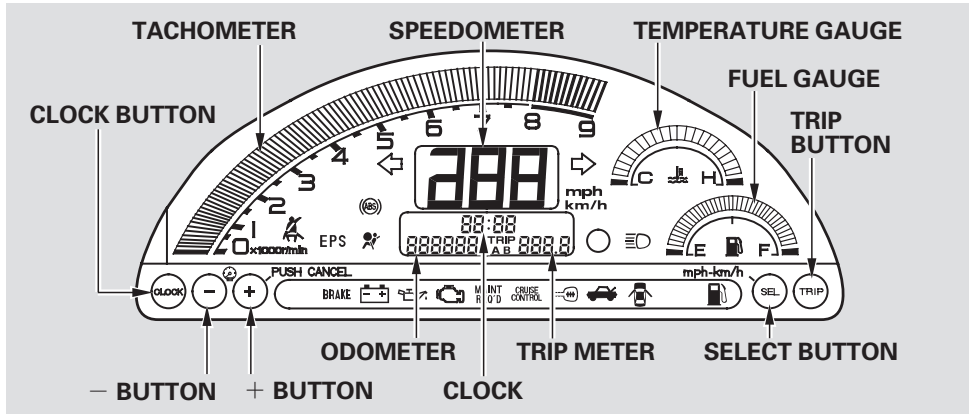

## Odometer

The odometer shows the total distance your vehicle has been driven in miles and kilometers. It is illegal under U.S. federal law and Canadian provincial regulations to disconnect, reset, or alter the odometer with the intent to change the number of miles and kilometers indicated.

## Trip Meter

This trip meter shows the number of miles or kilometers driven since you last reset it.

There are two trip meters: Trip A and Trip B. Switch between these displays by pressing the TRIP button repeatedly. Each trip meter works independently, so you can keep track of two different distances.

To reset a trip meter, display it, and then press and hold the TRIP button until you hear a beep and the number resets to "0.0".

## Select Button

The select button switches the speedometer reading between miles per hour and kilometers per hour. It also changes the odometer and trip meters to read in miles or kilometers correspondingly. To change the readings, push the SELECT button, and hold it until you hear a beep.

## Fuel Gauge

This shows how much fuel you have. It may show slightly more or less than the actual amount.

### NOTICE

*Avoid driving with an extremely low fuel level. Running out of fuel could cause the engine to misfire, damaging the catalytic converter.*

## Temperature Gauge

This shows the temperature of the engine's coolant. During normal operation, the reading should be in the middle of the gauge. In severe driving conditions, such as very hot weather or a long period of uphill driving, the reading may reach near the red mark. If it reaches the red (Hot) mark, pull safely to the side of the road. See page 167 for instructions and precautions on checking the engine's cooling system.

## Clock

The clock displays the time with the ignition switch in the ON (II) position.

To set the clock:

1. Turn the ignition switch to ON (II).
2. Press and hold the CLOCK button until the minute display blinks. Adjust the minute by pressing the + or – button.
3. When you finish the minute adjustment, press and release the CLOCK button. The hour display will blink. Adjust the hour by pressing the + or – button.
4. When you finish all the adjustments, press the CLOCK button again.

# Controls Near the Steering Wheel

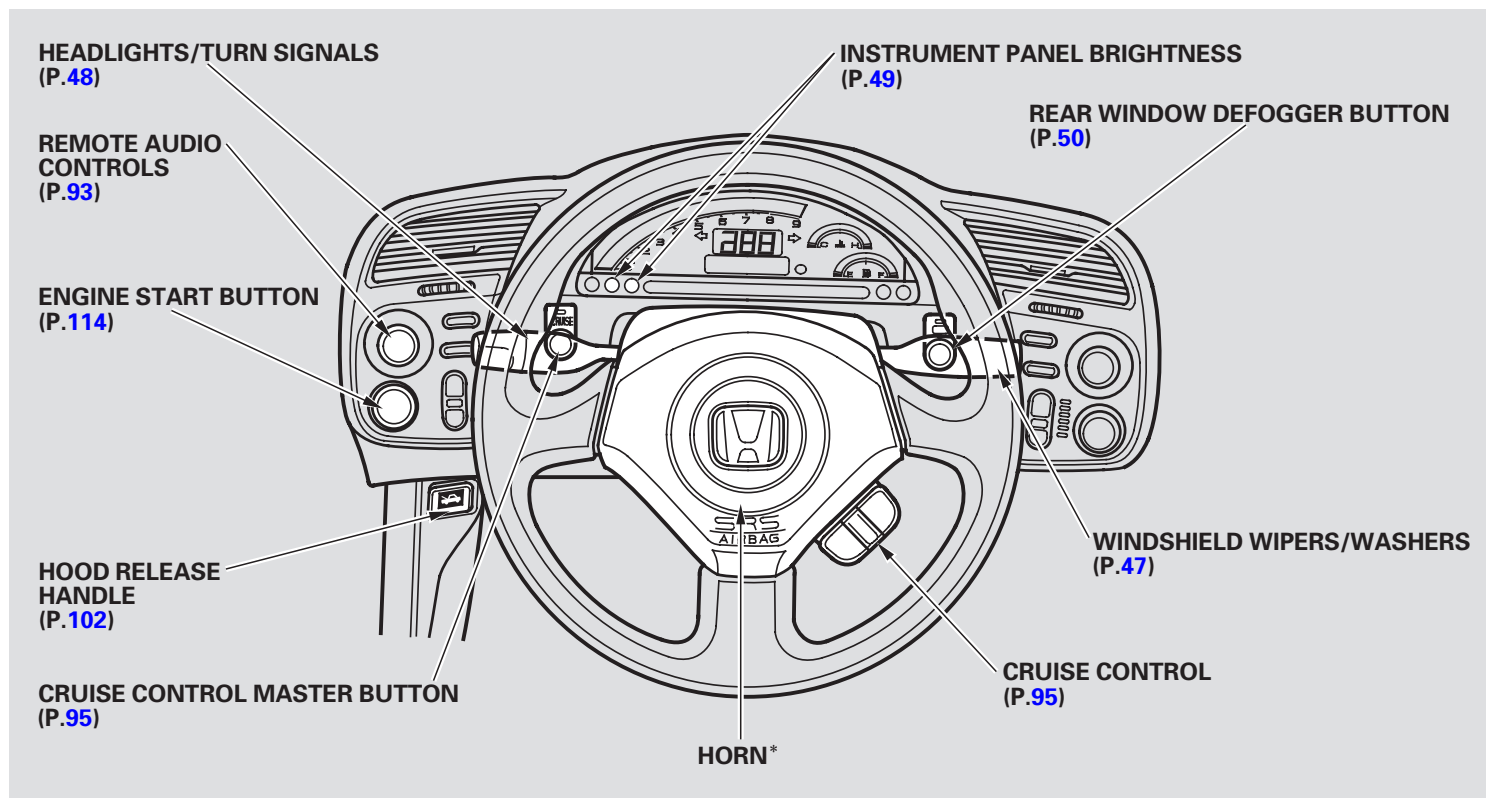

\* To use the horn, press the pad around the “H” logo.



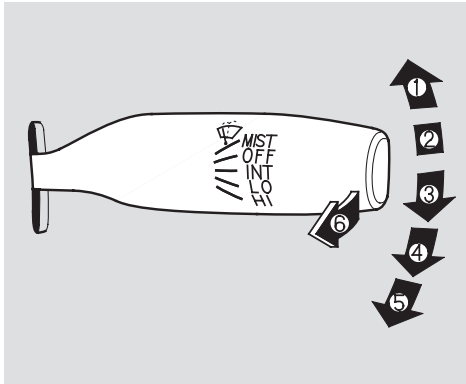

1. MIST
2. OFF
3. INT – Intermittent
4. LO – Low speed
5. HI – High speed
6. Windshield Washers

Push the right lever up or down to select a position.

**MIST** – The wipers run at high speed until you release the lever.

**OFF** – The wipers are not activated.

**INT** – The wipers operate every few seconds. In low speed and high speed, the wipers run continuously.

**LO** – The wipers run at low speed.

**HI** – The wipers run at high speed.

**Windshield Washers** – Pull the wiper control lever toward you and hold it. The washers spray until you release the lever. The wipers run at low speed, then complete one more sweep after you release the lever.

## Turn Signal and Headlights

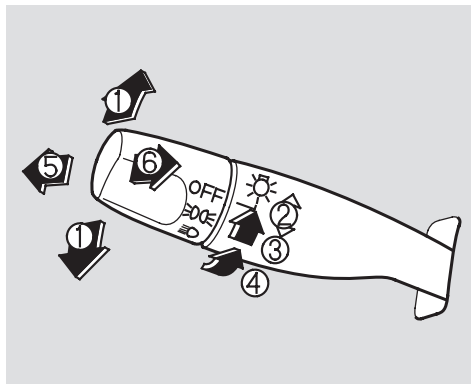

1. Turn Signal
2. Off
3. Parking and indicator lights
4. Headlights on
5. High beams
6. Flash high beams

**Turn Signal** — Push down on the left lever to signal a left turn and up to signal a right turn. To signal a lane change, push lightly on the lever and hold it. The lever will return to center when you release it or complete a turn.

**Headlights On** — Turning the switch to the “☀” position turns on the parking lights, taillights, instrument panel lights, side-marker lights, and rear license plate lights.

Turning the switch to the “☀” position turns on the headlights. If you leave the lights on with the key removed from the ignition switch, you will hear a reminder buzzer when you open the driver’s door.

**High Beams** — Push the lever forward until you hear a click to turn on the high beams. The blue high beam indicator will come on (see page 42 ). Pull the lever back to return to the low beams.

To flash the high beams, pull the lever back lightly, then release it. The high beams will stay on as long as you hold the lever back.

### Daytime Running Lights

*Canadian models only*

With the headlight switch off, the high beam headlights come on with reduced brightness when you turn the ignition switch to ON (II) and release the parking brake. They remain on until you turn the ignition switch off, even if you set the parking brake.

The headlights revert to normal operation when you turn them on with the switch.

# Instrument Panel Brightness, Hazard Warning Button

## Instrument Panel Brightness

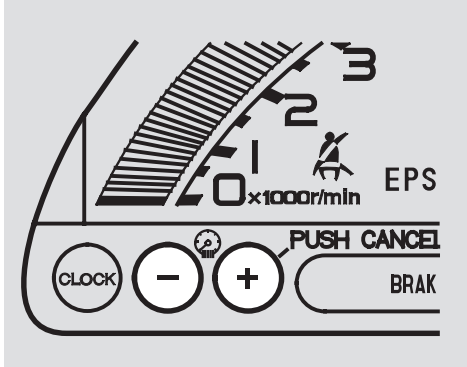

The buttons in the lower left corner of the instrument panel adjust the brightness of the display in five steps. Push the + or - button five times to see the full range.

To reduce glare at night, the instrument panel illumination dims when you turn the light switch to  or .

Adjust the brightness to the desired level with the headlight switch off, and also with the headlight switch on. Both settings will remain at those levels until you change them.

With the headlight switch on, you can switch the display to full daytime brightness by pushing and holding the + button. Push the - button to return the display to the original brightness.

## Hazard Warning Button

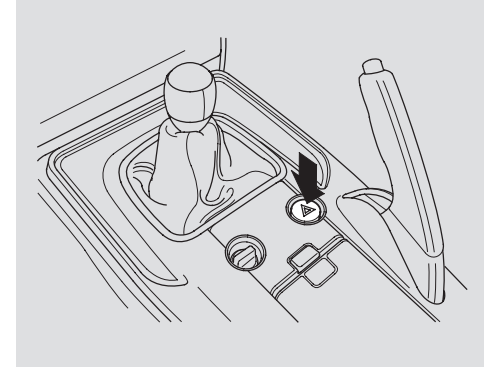

Push the red button next to the parking brake to turn on the hazard warning lights (four-way flashers). This causes all four outside turn signals and both indicators in the instrument panel to flash. Use the hazard warning lights if you need to park in a dangerous area near heavy traffic, or if your vehicle is disabled.

## Rear Window Defogger

---

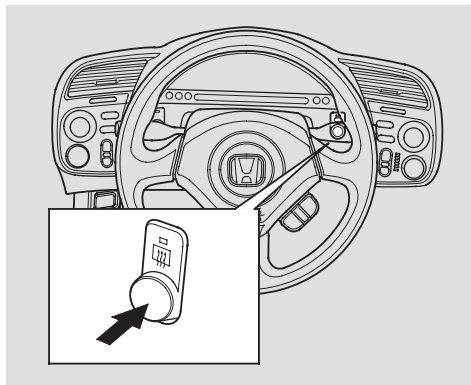

The rear window defogger will clear fog, frost, and thin ice from the window. Push the defogger button to turn it on and off. The indicator in the button comes on to show the defogger is on. If you do not turn it off, the defogger will shut itself off after about 15 minutes. It also shuts off when you turn off the ignition switch. You have to turn the defogger on again when you restart the vehicle.

Do not push the defogger button when the convertible top is folded.

Make sure the rear window is clear and you have good visibility before starting to drive.

The defogger wires on the inside of the rear window can be accidentally damaged. When cleaning the glass, always wipe side to side.

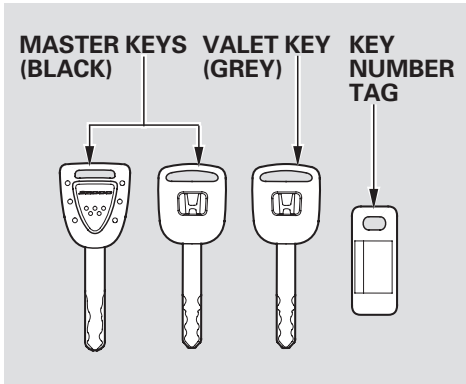

The master key fits all the locks on your vehicle.

The valet key works only in the ignition and the door locks. You can keep the trunk and the lower console compartment locked when you leave your vehicle and the valet key at a parking facility.

You should have received a key number tag with your keys. You will need this key number if you ever have to get a key replaced. Use only Honda-approved key blanks.

These keys contain electronic circuits that are activated by the Immobilizer System. They will not work to start the engine if the circuits are damaged.

- Protect the keys from direct sunlight, high temperature, and high humidity.
- Do not drop the keys or set heavy objects on them.
- Keep the keys away from liquids. If they get wet, dry them immediately with a soft cloth.

The keys do not contain batteries. Do not try to take them apart.

## Immobilizer System

---

The Immobilizer System protects your vehicle from theft. If an improperly-coded key (or other device) is used, the engine's fuel system is disabled.

When you turn the ignition switch to ON (II), the Immobilizer System indicator should come on for a few seconds, then go out. If the indicator starts to blink, it means the system does not recognize the coding of the key. Turn the ignition switch to LOCK (0), remove the key, reinsert it, and turn the switch to ON (II) again.

The system may not recognize your key's coding if another immobilizer key or other metal object (i.e. key fob) is near the ignition switch when you insert the key.

If the system repeatedly does not recognize the coding of your key, contact your dealer.

Do not attempt to alter this system or add other devices to it. Electrical problems could result that may make your vehicle undriveable.

If you have lost your key and cannot start your engine, contact your dealer.

*As required by the FCC:*

*This device complies with Part 15 of the FCC rules. Operation is subject to the following two conditions: (1) This device may not cause harmful interference, and (2) this device must accept any interference received, including interference that may cause undesired operation.*

*Changes or modifications not expressly approved by the party responsible for compliance could void the user's authority to operate the equipment.*

*This device complies with Industry Canada Standard RSS-210.*

*Operation is subject to the following two conditions: (1) this device may not cause interference, and (2) this device must accept any interference that may cause undesired operation of the device.*

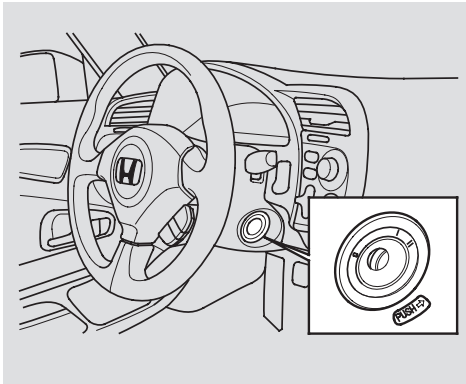

The ignition switch has three positions: LOCK (0), ACCESSORY (I), and ON (II).

**LOCK (0)** — You can insert or remove the key only in this position. To turn the key, push it in slightly.

If the front wheels are turned, the anti-theft lock may make it difficult to turn the key. Firmly turn the steering wheel to the left or right as you turn the key.

**ACCESSORY (I)** — You can operate the audio system and the accessory power socket in this position.

**ON (II)** — This is the normal key position when driving. Several of the indicators on the instrument panel come on as a test when you turn the ignition switch from ACCESSORY (I) to ON (II).

The engine can be started with the key in this position by pressing the engine START button (see page 114).

You will hear a reminder beeper if you leave the key in the ignition switch in the LOCK (0) or ACCESSORY (I) position and open the driver's door. Remove the key to turn off the beeper.

## **⚠ WARNING**

Removing the key from the ignition switch while driving locks the steering. This can cause you to lose control.

Remove the key from the ignition switch only when parked.

# Power Door Locks, Trunk

## Power Door Locks

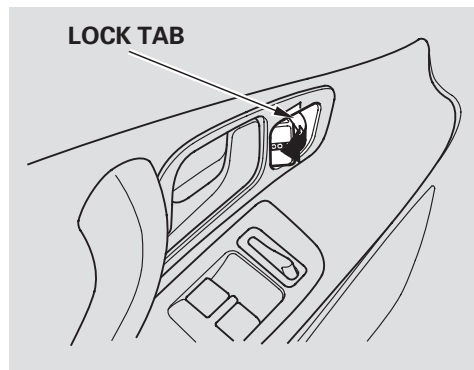

Each door has a lock tab next to the inside door handle. When you push in the lock tab on the driver's door, both doors lock. Pulling out the lock tab on the driver's door only unlocks that door. The lock tab on the passenger's door only locks and unlocks that door.

To lock the passenger's door when getting out of the vehicle, push the lock tab in and close the door. To lock the driver's door, remove the key from the ignition switch, pull out either the inside or outside door handle and push the lock tab in, then close the door.

Both doors lock when you use the key in the driver's door. Using the key in the passenger's door only locks and unlocks that door. To unlock only the driver's door from the outside, insert the key in the driver's door lock, turn the key and release it. If you turn the key and hold it, both doors will unlock.

## Trunk

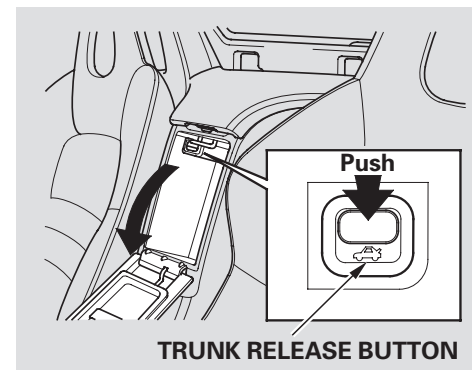

To open the trunk, press the trunk release button in the lower console compartment. To protect items in the trunk when you need to give the key to someone else, lock the lower console compartment with the master key, and give the other person the valet key.

To close the trunk, press down on the trunk lid.



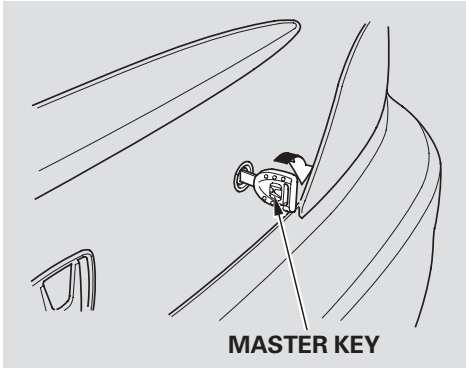

You can also use the master key to open the trunk lock.

To open the trunk with the remote transmitter, press and hold the TRUNK RELEASE button for about 1 second (see page 56).

Keep the trunk lid closed at all times while driving to avoid damaging the lid, and to prevent exhaust gas from getting into the interior. See **Carbon Monoxide Hazard** on page. 35

## Emergency Trunk Opener

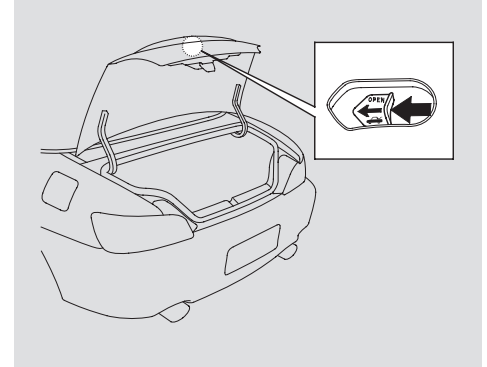

As a safety feature, your vehicle has a release lever on the trunk latch so the trunk can be opened from the inside. To open the trunk, push the release lever to the left.

Parents should decide if their children should be shown how to use this feature. For more information about child safety, see page 26.

## Remote Transmitter

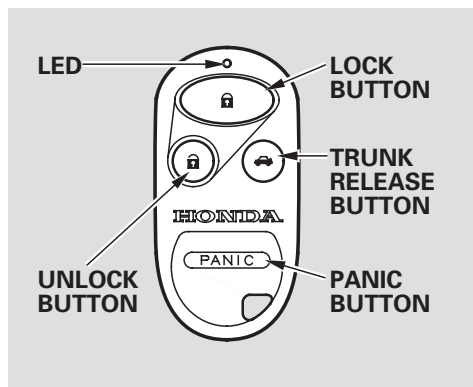

**LOCK** — Press this button once to lock both doors. Some exterior lights will flash. When you push **LOCK** twice within 5 seconds, you will hear a beep to verify that the doors are locked.

**UNLOCK** — Press this button once to unlock the driver's door. Push it twice to also unlock the passenger's door.

The interior light (if the interior light

switch is in the center position) will come on when you press the **UNLOCK** button. If you do not open either door within 30 seconds, the light goes out. If you relock the doors with the remote transmitter before 30 seconds have elapsed, the light will go off immediately.

If you do not open either door within 30 seconds, the doors automatically relock.

You cannot lock or unlock the doors with the remote transmitter if either door is not fully closed or the key is in the ignition switch.

**TRUNK** — Press this button for about 1 second to open the trunk. You cannot open the trunk if the key is in the ignition switch.

**PANIC** — Press this button for about 1 second to attract attention; the horn will sound and the exterior

lights will flash for about 30 seconds. To cancel panic mode, press any other button on the remote transmitter, or turn the ignition switch to ON (II).

### Remote Transmitter Care

- Avoid dropping or throwing the transmitter.
- Protect the transmitter from extreme temperature.
- Do not immerse the transmitter in any liquid.
- If you lose a transmitter, the replacement needs to be reprogrammed by your dealer.

## Replacing the Transmitter Battery

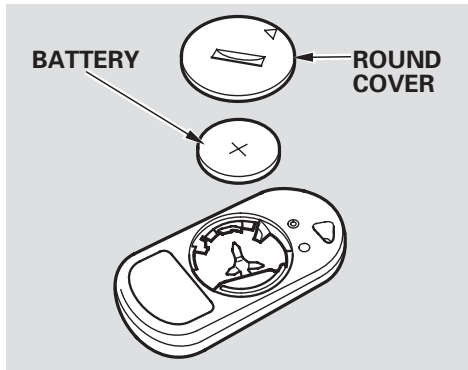

If it takes several pushes on the button to lock or unlock the doors, replace the battery as soon as possible.

Battery type: CR2025

To replace the battery, remove the round cover on the back of the transmitter by turning it counterclockwise with a coin. Insert a new battery with the + side facing up. Align the ∇ mark on the cover with the ⊙ mark on the transmitter. Set the cover in place, and turn it clockwise.

*As required by the FCC:*

*This device complies with Part 15 of the FCC rules. Operation is subject to the following two conditions: (1) This device may not cause harmful interference, and (2) this device must accept any interference received, including interference that may cause undesired operation.*

*Changes or modifications not expressly approved by the party responsible for compliance could void the user's authority to operate the equipment.*

*This device complies with Industry Canada Standard RSS-210.*

*Operation is subject to the following two conditions: (1) this device may not cause interference, and (2) this device must accept any interference that may cause undesired operation of the device.*

## Seats

See pages 10 – 12 for important safety information and warnings about how to properly position the seats and seat-backs.

Make all seat adjustments before you start driving.



To adjust the seat forward and backward, pull up on the lever under the seat cushion's front edge. Then try to move the seat to make sure it is locked in position.

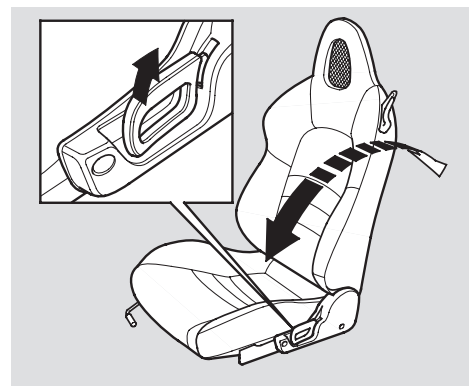

To change the seat-back angle, pull up on the lever on the outside of the seat bottom.

Turn the ignition switch to ON (II) to raise or lower either window. To open the window, push the switch down and hold it. Release the switch when you want the window to stop. Pull back on the switch and hold it to close the window.

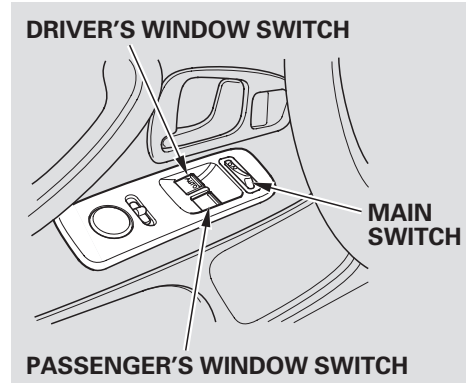

The driver's armrest has a master power window control panel. To open the passenger's window, push down on the switch and hold it until the window reaches the desired position. To close the window, pull back on the window switch. Release the switch when the window gets to the position you want.

### **⚠ WARNING**

Closing a power window on someone's hands or fingers can cause serious injury.

Make sure your passenger is away from the window before closing it.

## Power Windows

---

The master control panel also contains these extra features:

**AUTO** — To open the driver's window fully, push the window switch firmly down to the second detent, and release it. The window automatically goes all the way down. To stop the window, pull back on the window switch briefly.

To open the driver's window only partially, push the window switch down lightly and hold it. The window will stop as soon as you release the switch.

The AUTO function only works to lower the driver's window. To raise the window, you must pull back on the window switch and hold it until the window reaches the desired position.

If the MAIN switch is OFF, the passenger's window cannot be raised or lowered. Keep the MAIN switch off when you have a child in the vehicle so the child does not get injured by operating the window unintentionally.

The convertible top on your vehicle lowers and raises electrically.

It is advisable to raise the top whenever you park the vehicle. This helps to protect the vehicle from unexpected weather changes, and from theft of your valuables.

## NOTICE

- Do not operate the convertible top in freezing weather. You can damage the material and the mechanism.
- Do not operate the top if it is wet, dirty, or covered with ice or snow.
- Never drive the vehicle with the convertible top half open.
- Do not operate the convertible top if the vehicle is on a jack, a hoist, or on jack stands.
- Park your vehicle in the shade whenever possible. Extended exposure to sunlight can cause the convertible top to deteriorate.

## Lowering the Convertible Top

Before operating the convertible top, make sure the vehicle is parked on level ground, the rear defogger is off, and there is enough clearance above the top.

1. Apply the parking brake. The convertible top will not operate unless the parking brake is fully engaged.
2. Turn the ignition switch to ON (II).

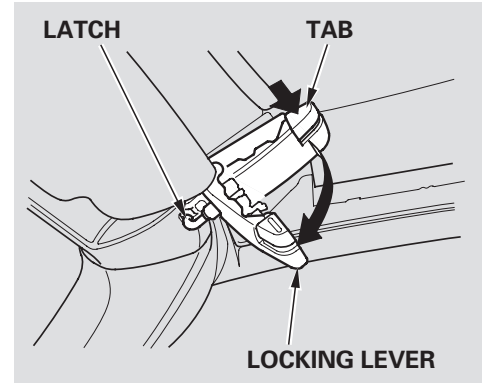

3. There is a latch on each side. Push in the tabs, and pull the locking levers down.

CONTINUED

## Convertible Top

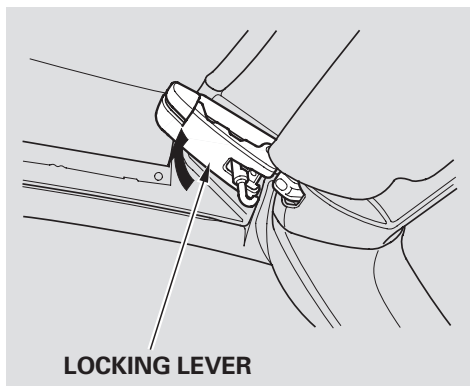

4. With the latches released, push the locking levers up until they latch.

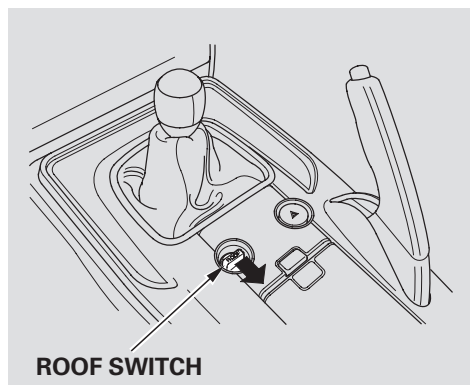

5. Pull back and hold the ROOF switch. The windows lower and the roof folds back. Release the ROOF switch when the roof is retracted completely into the rear shelf.

### NOTICE

*Do not sit on the folded convertible top, or any items on top of it. You could damage the top or the rear window.*

### ⚠ WARNING

Operating the convertible top while any part of a passenger is in the way of the convertible top can cause serious injury.

Make sure that you, your passenger, or any other people around the vehicle are clear of the moving convertible top.



## Convertible Top Cover

Use the convertible top cover when the top is folded to help prevent foreign objects, dirt, etc., from getting into the material and the mechanism.

The cover is attached to the body with four snaps: two behind the roll bars, and one on the side of each seat. To install or remove the convertible top cover *correctly*, do this:

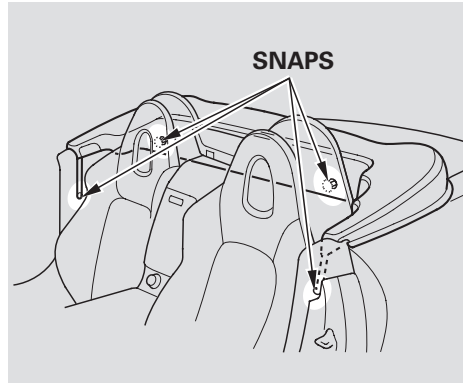

1. Remove the convertible top cover from the trunk, and lay it into position behind the roll bar.

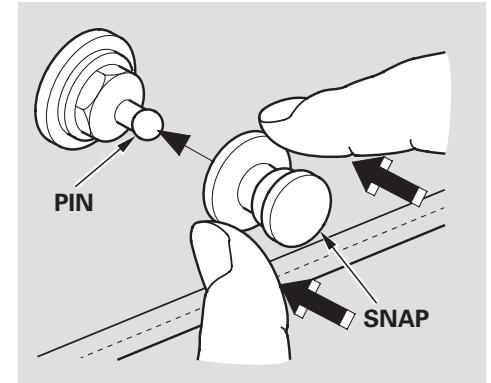

2. Hold the cover in place with its snap on the driver's side of the roll bar aligned with the pin on the roll bar. Press on both sides of the snap to attach it to the pin. Do not push or pull the snap button when installing the snap.
3. Align the snap on the passenger's side of the roll bar with the pin. Press on both sides of the snap to attach it to the pin.

*CONTINUED*

# Convertible Top

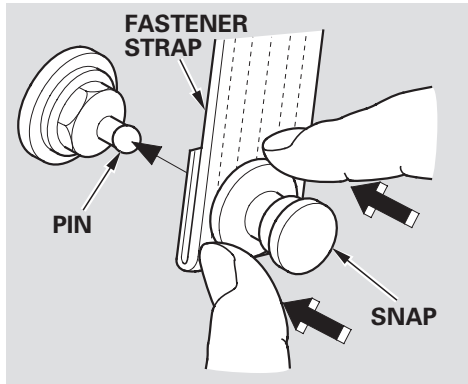

4. Pull down the strap on the passenger's side of the cover, and align its snap with the pin on the trim panel behind the door. Press on both sides of the snap to attach it to the pin.
5. Pull down the strap on the driver's side of the cover, and align its snap with the pin on the trim panel behind the door. Press on both sides of the snap to attach it to the pin.

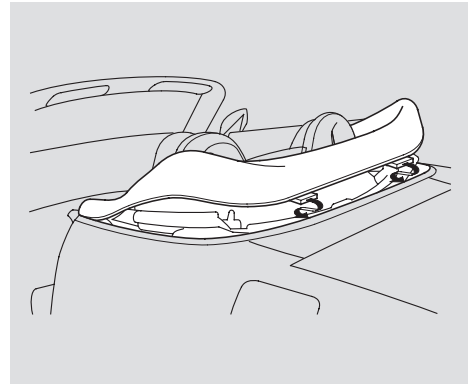

6. Fit the rear of the cover into the space between the convertible top and its molding.
7. To remove the cover, pull the snap buttons.

## Raising the Convertible Top

1. Apply the parking brake. The convertible top will not operate unless the parking brake is fully engaged.
2. Turn the ignition switch to ON (II).
3. Push the ROOF switch forward and hold it. The windows, if raised, will lower automatically.

The convertible top will rise. Release the ROOF switch when the top reaches the windshield header.

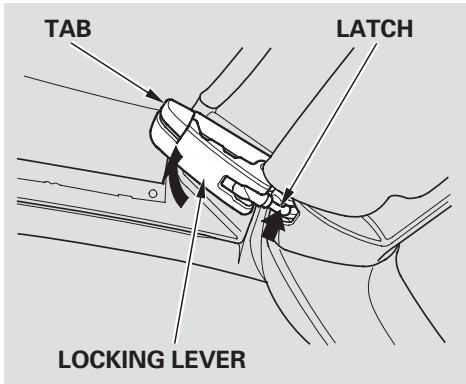

4. Push in the tab to release the locking levers, and pull them down. Note the movement of the latch when you push in the tab.
5. While holding the lever down, push in the tab to engage the latch in the windshield header. Pull the top down and forward if necessary.

6. Push the locking levers up while holding the tab. When the latch is in place, release the tab. Make sure the convertible top is securely latched.

## **⚠ WARNING**

Operating the convertible top while any part of a passenger is in the way of the convertible top can cause serious injury.

Make sure that you, your passenger, or any other people around the vehicle are clear of the moving convertible top.

## **NOTICE**

*Do not put any heavy items on the folded convertible top. You could damage the material and the mechanism.*

## **Maintenance**

Dust is the main cause of creaks or other sounds coming from the convertible top.

Regularly clean the body seals with glass cleaner and a soft cloth. Do not use a scraper or de-icing chemicals to remove frost, snow, or ice from the top or the rear window.

Every 3 to 6 months, depending on how often the top is folded, rub a thin film of Shin-Etsu Silicon Grease (available from your dealer, P/N 08798-9013) onto the seals wherever they touch the convertible top or each other.

## Convertible Top, Mirrors

### To reduce the possibility of leaks:

- Do not lean or sit on an open door.
- Do not push or pull the door glass to open and close the door.
- The convertible top seals are designed to promote the flow of water off the roof. Spraying high-pressure water directly on the seals can distort them, causing a leak. Use only a low-pressure water stream when using a hose, and avoid commercial car washes.

### Mirrors

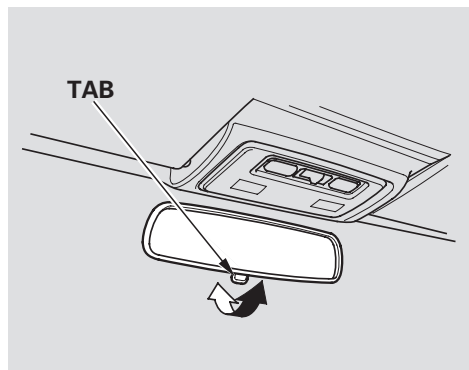

Keep the inside and outside mirrors clean and adjusted for best visibility. Be sure to adjust the mirrors before you start driving.

The inside mirror has day and night positions. The night position reduces glare from headlights behind you. Flip the tab on the bottom edge of the mirror to select the day or night position.

### Adjusting the Power Mirrors

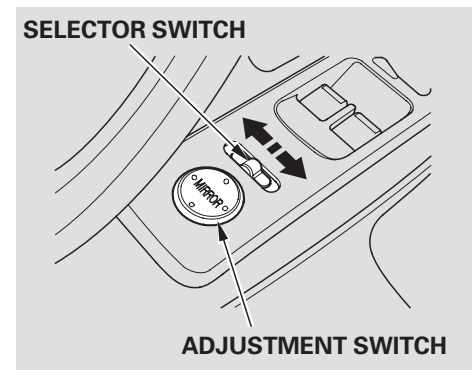

1. Turn the ignition switch to ON (II).
2. Move the selector switch to L (driver's side) or R (passenger's side).

3. Push the appropriate edge of the adjustment switch to move the mirror right, left, up, or down.
4. When you finish, move the selector switch to the center (off) position. This turns the adjustment switch off to keep your settings.

### Parking Brake

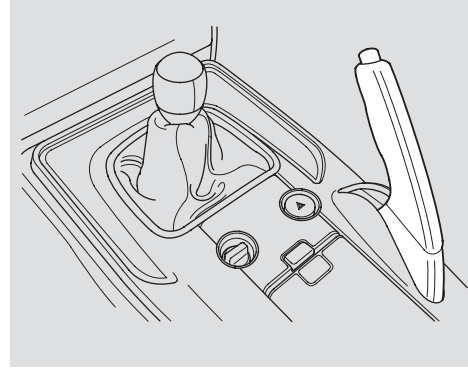

To apply the parking brake, pull the lever up fully. To release it, pull up slightly, push the button, and lower the lever. The parking brake indicator on the instrument panel should go out when the parking brake is fully released (see page 40 ).

If you try to drive the vehicle without releasing the parking brake, the ABS indicator may come on, and the ABS may not work properly.

#### NOTICE

*Driving the vehicle with the parking brake applied can damage the rear brakes and axles.*

If you drive at certain speeds without fully releasing the parking brake, a beeper sounds continuously.

## Interior Convenience Items

---

CONSOLE COMPARTMENT

ACCESSORY POWER SOCKET

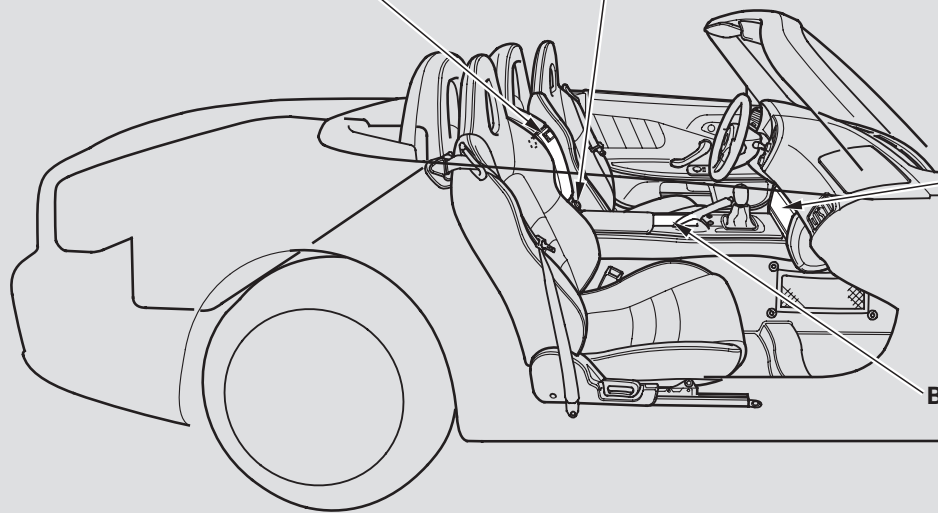

AUDIO PANEL

BEVERAGE HOLDER

## Beverage Holder

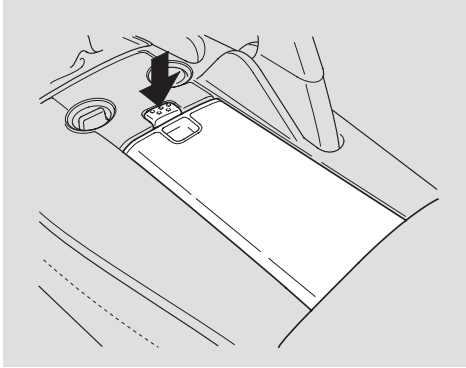

Open the beverage holder by pushing on the tab. The lid will slide open.

Be careful when you are using the beverage holder. A spilled liquid that is very hot can scald you or your passenger. Spilled liquids can also damage the upholstery, carpeting, and electrical components in the interior.

## Accessory Power Socket

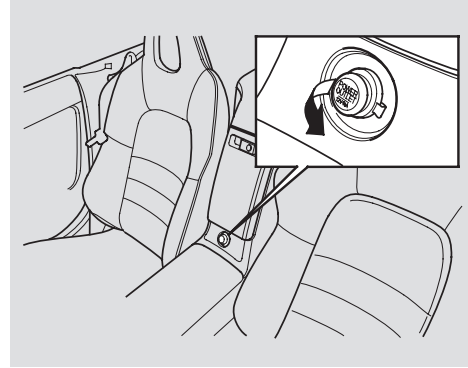

This socket is intended to supply power for 12 volt DC accessories that are rated 120 watts or less (10 amps).

It will not power an automotive type cigarette lighter element.

## Console Compartments

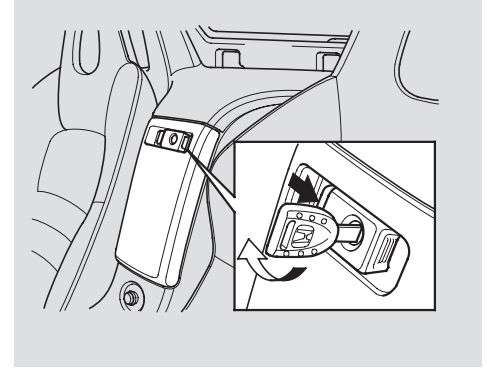

The area between the seats has two compartments. Open the lower compartment by squeezing the handle. Close it with a firm push. You can lock or unlock the lower compartment with the master key.

*CONTINUED*

## Interior Convenience Items

---

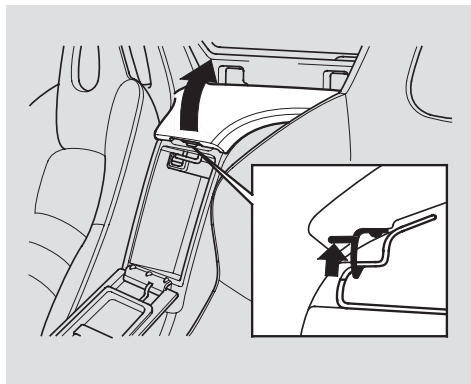

The lever to open the upper compartment is inside the lower compartment. Push up the lever, and lift the lid. To close, lower the lid, and push it down until it latches.

### Audio Panel

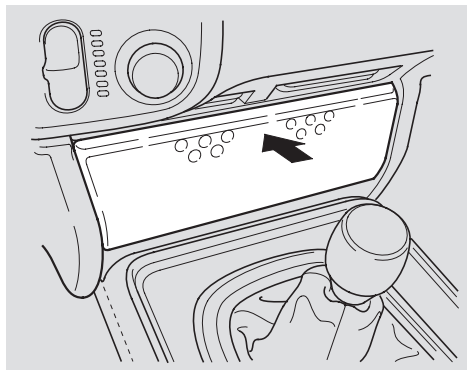

To open the audio panel, push on the top center, and let the panel swing down. To close, pivot the panel up, and push on it until it latches.



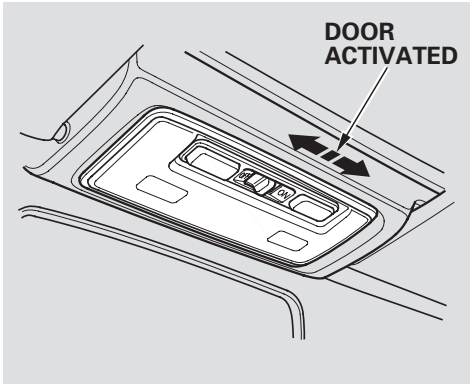

If the three-position switch is in the center position, the interior light will come on when you remove the key from the ignition switch.

The interior light has a three-position switch; ON, Door Activated, and OFF. In the Door Activated (center) position, the light comes on when you:

- Open either door.
- Unlock the doors with the key or remote transmitter.

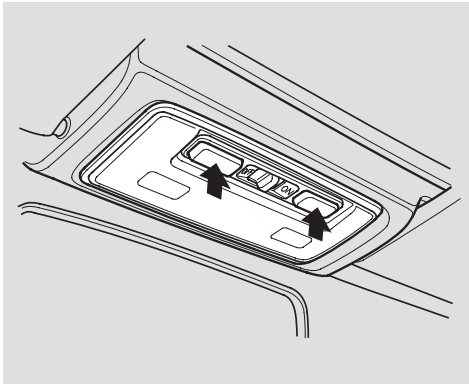

In addition, when the three position switch is in the center position with both doors closed, the two bulbs in the interior light can be turned on separately by the pushbutton switches next to them. Push the switch to turn the light on or off.



The heating and air conditioning systems in your vehicle provide a comfortable driving environment in all weather conditions.

The standard audio system has many features. This section describes those features and how to use them. (If you selected an optional audio system, refer to the operating instructions that came with it.)

Vents, Heating, and A/C .....	74
Playing the Radio .....	78
Radio Reception .....	81
Playing the XM <sup>®</sup> Satellite Radio ....	83
Playing a CD .....	88
CD Changer.....	90
Protecting Your CDs .....	90
CD Player Error Messages .....	91
CD Changer Error Messages .....	92
Remote Audio Controls.....	93
Radio Theft Protection.....	94
Cruise Control.....	95

# Vents, Heating, and A/C

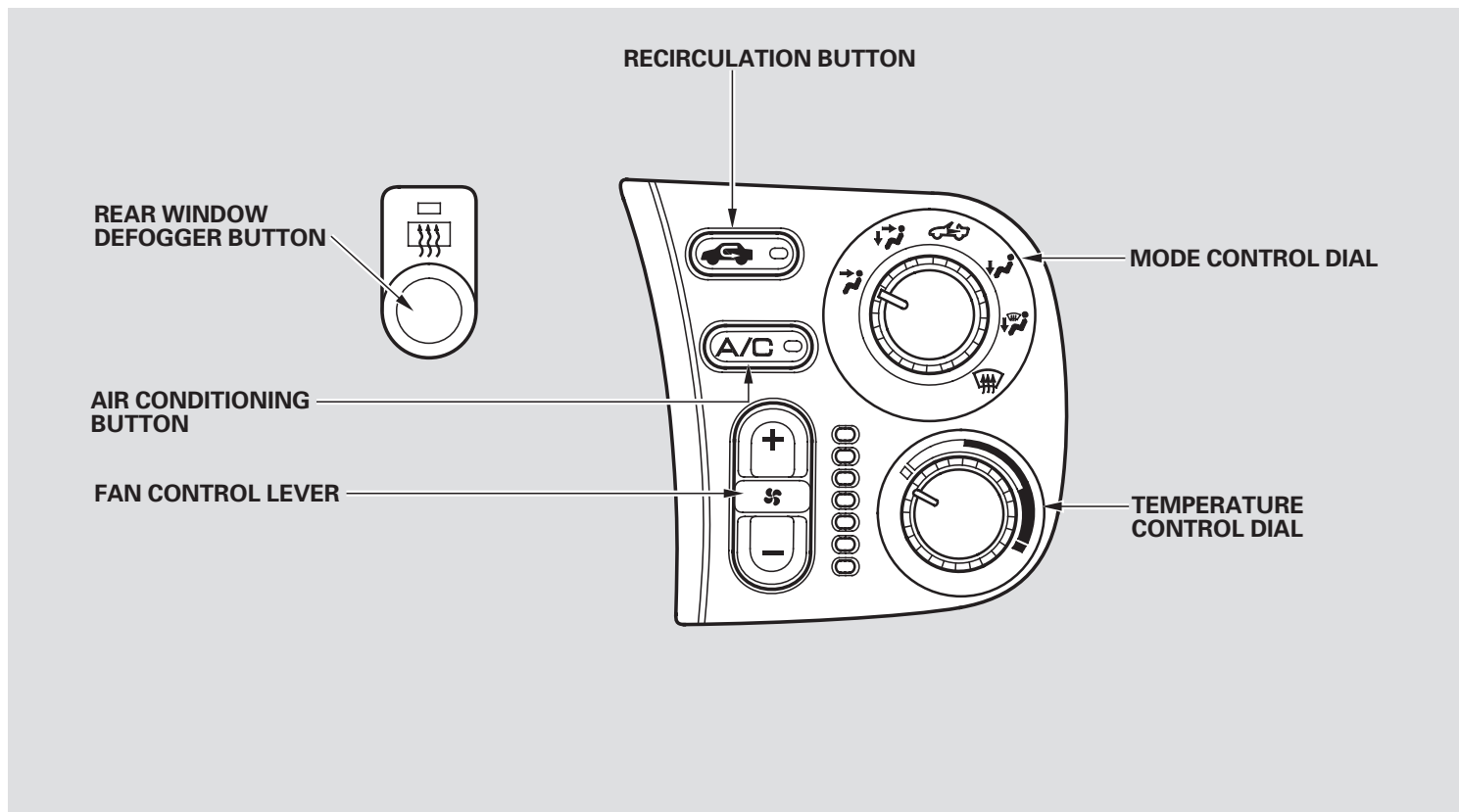

## Controlling the Airflow

### Fan Control Lever

Push this lever up and down to increase or decrease the fan speed and airflow. The indicators next to the lever show you the speed and airflow selected.

### Temperature Control Dial

Turning this dial clockwise increases the temperature of the airflow.

### Air Conditioning (A/C) Button

This button turns the air conditioning on and off. The indicator in the button comes on when the A/C is on.

### Recirculation Button

When the recirculation indicator is on, air from the vehicle's interior is sent through the system again (Recirculation mode). When the indicator is off, air is brought in from the outside of the vehicle (Fresh Air mode).

The outside air intakes for the heating and cooling system are at the base of the windshield. Keep this area clear of leaves and other debris.

The system should be left in Fresh Air mode under almost all conditions. Keeping the system in Recirculation mode, particularly with the A/C off, can cause the windows to fog up.

Switch to Recirculation mode when driving through dusty or smoky conditions, then return to Fresh Air mode.

### Rear Window Defogger Button

This button turns the rear window defogger off and on (see page 50).

Do not push the defogger button when the convertible top is folded.

### Mode Control Dial

Use the mode control dial to select the vents the air flows from. Some air will flow from the dashboard vents in all modes.

 Air flows from the vents on both sides of the instrument panel, and from the dashboard vent in front of the passenger.

 Airflow is divided between the vents in the dashboard and the floor vents.

CONTINUED

## Vents, Heating, and A/C



---

 Air flows from the center vents in the dashboard above the audio system, the vents on both sides of the instrument panel, and from the floor vents. Select this position when you drive with the convertible top folded.

 Air flows from the floor vents and the vents on both sides of the instrument panel.

 Airflow is divided between the floor vents and the defroster vents at the base of the windshield, and the vents on both sides of the instrument panel.

 Air flows from the defroster vents at the base of the windshield and the vents on both sides of the instrument panel.

When you select  or , the system automatically switches to Fresh Air mode and turns on the

A/C.

### Ventilation

The flow-through ventilation system draws in outside air, circulates it through the interior, then exhausts it through vents behind the seat-backs.

1. Set the temperature to the lower limit.
2. Make sure the A/C is off.
3. Select  and Fresh Air mode.
4. Set the fan to the desired speed.

### Using the Heater

The heater uses engine coolant to warm the air. If the engine is cold, it will be several minutes before you feel warm air coming from the system.

1. Select  and Fresh Air mode.
2. Set the fan to the desired speed.
3. Adjust the warmth of the air with the temperature control dial.

### Using the A/C

Air conditioning places an extra load on the engine. Watch the engine coolant temperature gauge (see page 45). If it moves near the red zone, turn off the A/C until the gauge reads normally.

1. Turn on the A/C by pressing the button. The indicator in the button comes on when a fan speed is selected.
2. Make sure the temperature is set to maximum cool.
3. Select .
4. If the outside air is humid, select Recirculation mode. If the outside air is dry, select Fresh Air mode.
5. Set the fan to the desired speed.

*If the interior is very warm, you can cool it down more rapidly by partially opening the windows, turning on the A/C, and setting the fan to maximum speed in Fresh Air mode.*

## To Dehumidify the Interior

Air conditioning, as it cools, removes moisture from the air. When used in combination with the heater, it makes the interior warm and dry.

1. Turn the fan on.
2. Turn on the air conditioning.
3. Select  and Fresh Air mode.
4. Adjust the temperature to your preference.

This setting is suitable for all driving conditions whenever the outside temperature is above 32°F (0°C).

## To Defog and Defrost

To remove fog from the inside of the windows:



1. Set the fan to the desired speed. Select high for faster defrosting.
2. Select . The system automatically switches to Fresh Air mode and turns on the A/C.
3. Adjust the temperature so the

airflow feels warm.

4. Select  to help clear the rear window.
5. To increase airflow to the windshield, close the corner vents.

When you switch to another mode from , the A/C stays on. Press the A/C button to turn it off.

## To Remove Exterior Frost or Ice From the Windows

1. Select . The system automatically switches to Fresh Air mode and turns on the A/C.
2. Select .
3. Set the fan and temperature controls to the maximum level.

To clear the windows faster, you can close the dashboard corner vents and the vents on both sides of the instrument panel by rotating the wheel below the vent. This will send more warm air to the windshield

defroster vents. Once the windshield is clear, select Fresh Air mode to avoid fogging the windows.

For your safety, make sure you have a clear view through all the windows before driving.

## To Turn Everything Off

Push the fan control level down until the indicator goes off. A lack of airflow can cause the windows to fog up. You should keep the fan on at all times so stale air and moisture do not build up in the interior and cause fogging.

# Playing the Radio

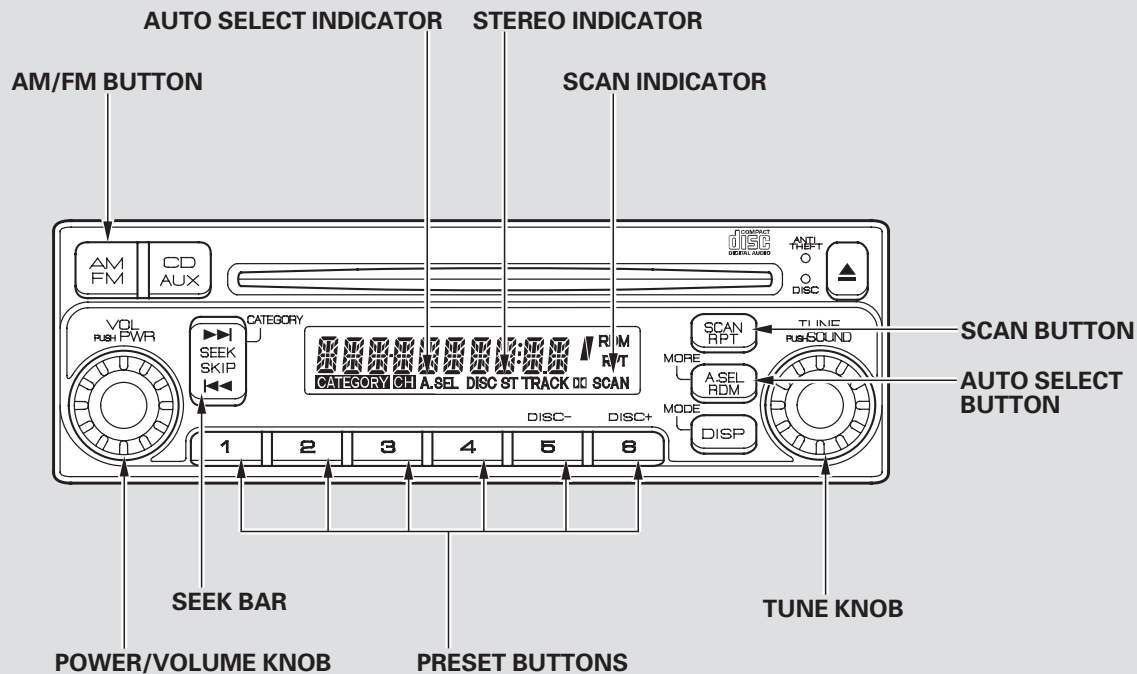



## To Play the Radio

The ignition switch must be in the ACCESSORY (I) or ON (II) position. Turn the system on by pushing the PWR/VOL knob or the AM/FM button. Adjust the volume by turning the PWR/VOL knob.

The band and frequency that the radio was last tuned to is displayed. To change bands, press the AM/FM button. On the FM band, ST will be displayed if the station is broadcasting in stereo. Stereo reproduction on AM is not available.

## To Select a Station

You can use these five methods to find radio stations on a selected band: **TUNE**, **SEEK**, **SCAN**, the preset buttons, and **AUTO SELECT**.

**TUNE** — Use the TUNE knob to tune the radio to a desired frequency. Turn the knob right to tune to a higher frequency, or left to tune to a

lower frequency.

**SEEK** — The SEEK function searches up and down from the current frequency to find a station with a strong signal. To activate it, press the **◀◀** or **▶▶** side of the bar, then release it.

**SCAN** — The SCAN function samples all stations with strong signals on the selected band. To activate it, press the SCAN button, then release it. You will see SCAN in the display. The system will scan for a station with a strong signal. When it finds one, it will stop and play that station for about 5 seconds.

If you do nothing, the system will scan for the next strong station and play it for 5 seconds. When it plays a station you want to listen to, press the SCAN button again.

**Preset** — Each preset button can store one frequency on AM, and two frequencies on FM.

1. Select the desired band, AM or FM. FM1 and FM2 let you store two frequencies with each preset button.
2. Use the TUNE, SEEK, or SCAN function to tune the radio to a desired station.
3. Pick a preset button, and hold it until you hear a beep.
4. Repeat steps 1 through 3 to store a total of six stations on AM and twelve stations on FM.

The preset frequencies will be lost if your vehicle's battery goes dead, is disconnected, or the radio fuse is removed.

*CONTINUED*

## Playing the Radio

---

**AUTO SELECT** — If you are traveling far from home and can no longer receive your preset stations, you can use the Auto Select feature to find stations in the local area.

Press the A. SEL button. “A.SEL” flashes in the display, and the system goes into scan mode for several seconds. It stores the frequencies of six AM, and twelve FM stations in the preset buttons.

You will see a “0” displayed after pressing a preset button if Auto Select cannot find a strong station for every preset button.

If you do not like the stations Auto Select has stored, you can store other frequencies on the preset buttons as previously described.

*To turn off Auto Select, press the A. SEL button. This restores the presets you originally set.*

### **Adjusting the Sound**

**BAL** — Adjust the Balance, or side-to-side strength of the sound.

**FAD** — Adjust the Fader, or the front-to-back strength of the sound.

**TRE** — Adjust the Treble in the sound.

**BAS** — Adjust the Bass in the sound.

Press the SOUND (TUNE) knob repeatedly to display Bass (BAS), Treble (TRE), Balance (BAL), and Fader (FAD) settings.

Turn the knob to adjust the setting. When the level reaches the center, you will see a “C” in the display. The system will return to the audio display in about 5 seconds.

### **Audio System Lighting**

You can use the instrument panel brightness control buttons to adjust the illumination of the audio system (see page 49). The audio system illuminates when the parking lights are on, even if the radio is off.

## Radio Frequencies

The radio can receive the complete AM and FM bands.

Those bands cover these frequencies:

AM band: 530 to 1,710 kilohertz

FM band: 87.7 to 107.9 megahertz

Radio stations on the AM band are assigned frequencies at least ten kilohertz apart (530, 540, 550).

Stations on the FM band are assigned frequencies at least 0.2 megahertz apart (87.9, 88.1, 88.3).

Stations must use these exact frequencies. It is fairly common for stations to round-off the frequency in their advertising, so your radio could display a frequency of 100.9 even though the announcer may identify the station as “FM101.”

## Radio Reception

How well the radio receives stations is dependent on many factors, such as the distance from the station’s transmitter, nearby large objects, and atmospheric conditions.

A radio station’s signal gets weaker as you get farther away from its transmitter. If you are listening to an AM station, you will notice the sound volume becoming weaker and the station drifting in and out. If you are listening to an FM station, you will see the stereo indicator flickering off and on as the signal weakens. Eventually, the stereo indicator will go off and the sound will fade completely as you get out of range of the station’s signal.

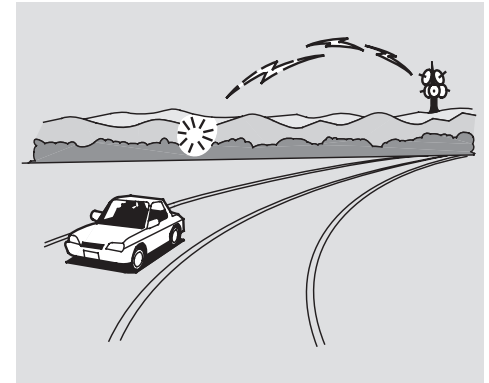

Driving very near the transmitter of a station that is broadcasting on a frequency close to the frequency of the station you are listening to can also affect your radio’s reception. You may temporarily hear both stations, or hear only the station you are close to.

*CONTINUED*

## Radio Reception

---

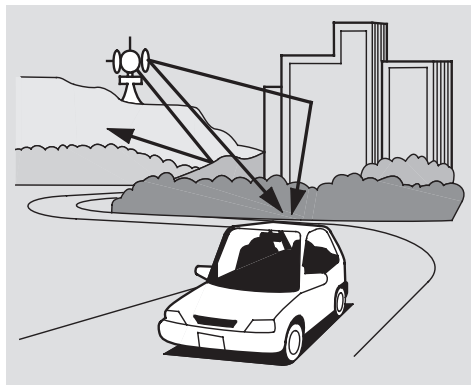

Radio signals, especially on the FM band, are deflected by large objects such as buildings and hills. Your radio then receives both the direct signal from the station's transmitter, and the deflected signal. This causes the sound to distort or flutter. This is a main cause of poor radio reception in city driving.



Radio reception can be affected by atmospheric conditions such as thunderstorms, high humidity, and even sunspots. You may be able to receive a distant radio station one day and not receive it the next day because of a change in conditions.

Electrical interference from passing vehicles and stationary sources can cause temporary reception problems.

*As required by the FCC:  
Changes or modifications not expressly  
approved by the party responsible for  
compliance could void the user's  
authority to operate the equipment.*

# Playing the XM® Satellite Radio (Optional on U.S. Models)

*Optional on U.S. models*

*Not available on Canadian models*

Your vehicle is capable of receiving XM® Satellite Radio anywhere in the United States, except Hawaii and Alaska.

XM® is a registered trademark of XM Satellite Radio, Inc.

Satellite radio receives signals from two satellites to produce clear, high-quality digital reception. It offers many channels in several categories. Along with a large selection of different types of music, satellite radio also allows you to view channel and category selections in the audio display.

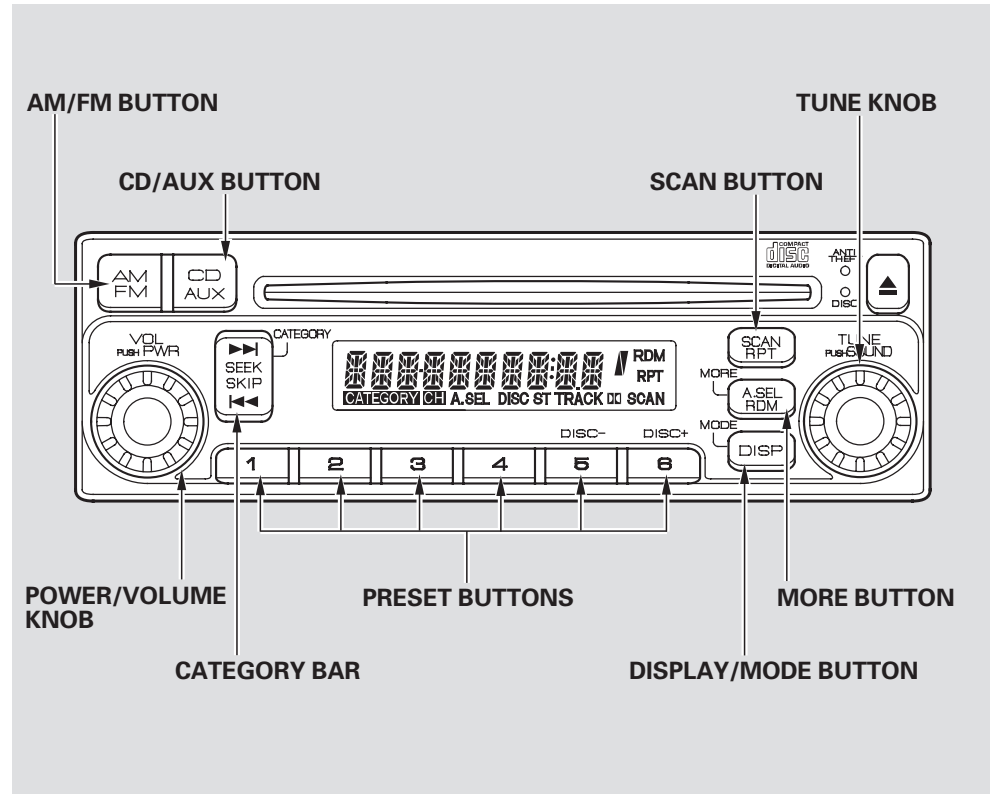

## Playing the XM® Satellite Radio (Optional on U.S. Models)

---

### Playing the Satellite Radio

To listen to satellite radio, turn the ignition switch to the ACCESSORY (I) or ON (II) position. Push the PWR/VOL knob to turn on the audio system, and press the CD/AUX button. Adjust the volume by turning the PWR/VOL knob. The last channel you listened to will show in the display.

**DISPLAY/MODE** — Each time the DISP button is pressed and released, the display information changes in the following sequence: channel name, channel number, category, artist name, and music title.

You may experience periods when XM radio does not transmit the artist name and or the song title information. If this happens, there is nothing wrong with your system. This information is not available under certain situations.

If you press and hold the DISP/MODE button for 5 seconds, it will change between category mode and channel mode. The display will show CH for the channel mode or CATEGORY for the category mode.

In the channel mode, you can receive all of the available channels in all of the different categories. In category mode, you will receive only the stations within the selected category.

**MORE** — Expands the display to show the 6 remaining letters beyond the first 10 letters in an artist's name or song title. The system is set up so only 16 letters can be displayed for

any title or name. Press MORE to view the next 6 letters. The system will return to the original display after 8 seconds.

**TUNE** — Turn the TUNE knob left to go down the channels or right to go up. In the channel mode, the TUNE knob will tune up or down through all the channels available from the XM radio. In the category mode, the TUNE knob will cycle through only the channels within the category you have currently selected.

**CATEGORY (SEEK/SKIP)** — Use the CATEGORY bar to select a desired category, such as jazz, rock, classical, etc. In both category mode and channel mode, pressing the category bar will change the category up or down.

## Playing the XM<sup>®</sup> Satellite Radio (Optional on U.S. Models)

**SCAN** – The SCAN function gives you a sampling of all channels while in the channel mode. In the category mode, only the stations within that category are scanned. To activate SCAN, press the SCAN button. The system plays each channel in numerical order for a few seconds, then selects the next channel. When you hear a channel you want to continue listening to, press the button again.

To store a channel:

**Preset** – You can store up to 12 preset channels using the six preset buttons. Each button stores one channel from the XM1 band and one channel from the XM2 band.

To store a channel:

1. Press the CD/AUX button. Either XM1 or XM2 will show in the display.
2. Use the TUNE knob, the CATEGORY bar, or the SCAN buttons to tune to a desired channel.

In the category mode, only channels within that category can be selected. In the channel mode, all channels can be selected.

3. Pick the preset button you want for that channel. Press and hold the button until you hear a beep.
4. Repeat steps 2 through 3 to store the first six channels.
5. Press the CD/AUX button again. The available XM band will show. Store the next six channels using steps 2 through 3.

Once a channel is stored, simply press and release the proper preset button to tune to it.

The presets will be lost if your vehicle's battery goes dead, is disconnected, or the radio fuse is removed.

*CONTINUED*

## Playing the XM® Satellite Radio (Optional on U.S. Models)

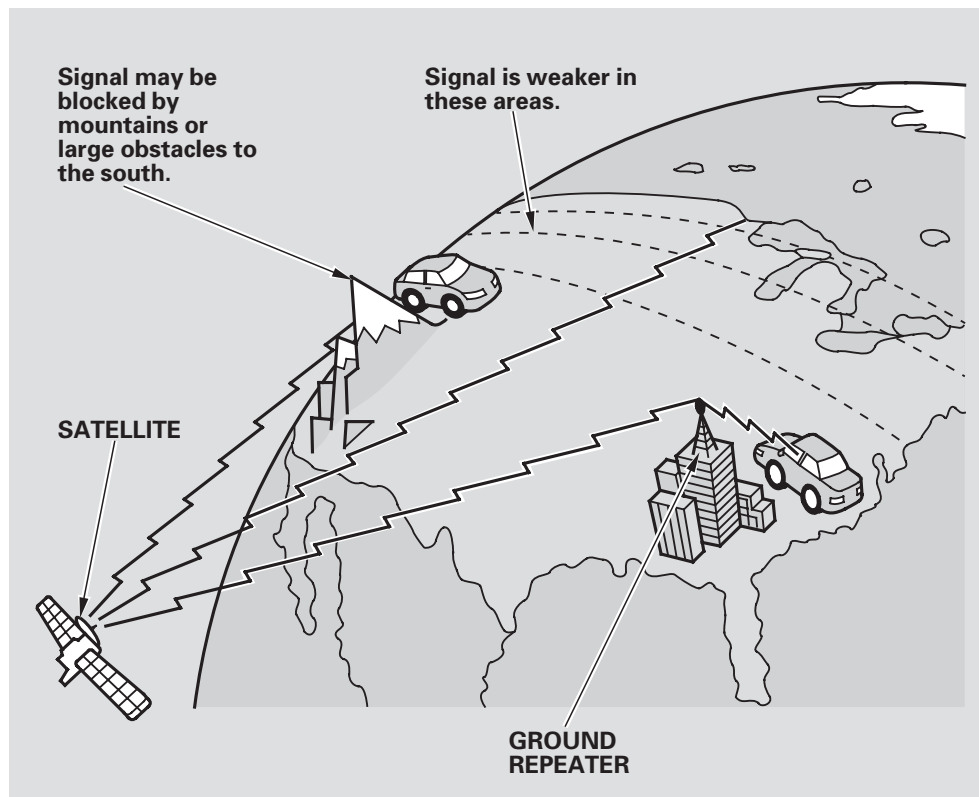

The XM satellites are in orbit over the equator; therefore, objects south of the vehicle may cause satellite reception interruptions. To help compensate for this, ground-based repeaters are placed in major metropolitan areas.

Satellite signals are more likely to be blocked by tall buildings and mountains the farther north you travel from the equator.



## Playing the XM® Satellite Radio (Optional on U.S. Models)

Depending on where you drive, you may experience reception problems. Interference can be caused by any of these conditions:

- Driving on the south side of an east/west mountain road
- Driving on the north side of a large commercial truck on an east/west road
- Driving in the tunnels
- Driving on a road beside a vertical wall, steep cliff, or hill to the south of you
- Driving on the lower level of a multi-tiered road
- Driving on a single lane road alongside dense trees taller than 50 ft. (15 m) to the south of you

There may also be other geographic situations that could affect satellite radio reception.

*As required by the FCC:  
Changes or modifications not expressly approved by the party responsible for compliance could void the user's authority to operate the equipment.*

### Receiving Satellite Radio Service

If your XM Radio service has expired, or you purchased your vehicle from a previous owner, you can listen to a sampling of the broadcasts available on XM Satellite Radio. With the ignition switch in the ACCESSORY (I) or ON (II) position, push the PWR/VOL knob to turn on the audio system, and press the CD/AUX button. A variety of music types and styles will play.

If you decide to purchase XM Satellite Radio service, contact XM Radio at [www.xmradio.com](http://www.xmradio.com), or at

1-800-852-9696. You will need to give them your radio I.D. number and your credit card number. To get your radio I.D. number, turn the TUNE knob until "0" appears in the display. Your I.D. will appear in the display.

After you've registered with XM Radio, keep your audio system in the Satellite Radio mode while you wait for activation. This should take about 30 minutes.

While waiting for activation, make sure your vehicle remains in an open area with good reception. Once your audio system is activated, "category" or "CH" will appear in the display, and you'll be able to listen to XM Radio broadcasts. XM Radio will continue to send an activation signal to your vehicle for at least 12 hours from the activation request. If the service has not been activated after 36 hours, contact XM Radio.

# Playing a CD

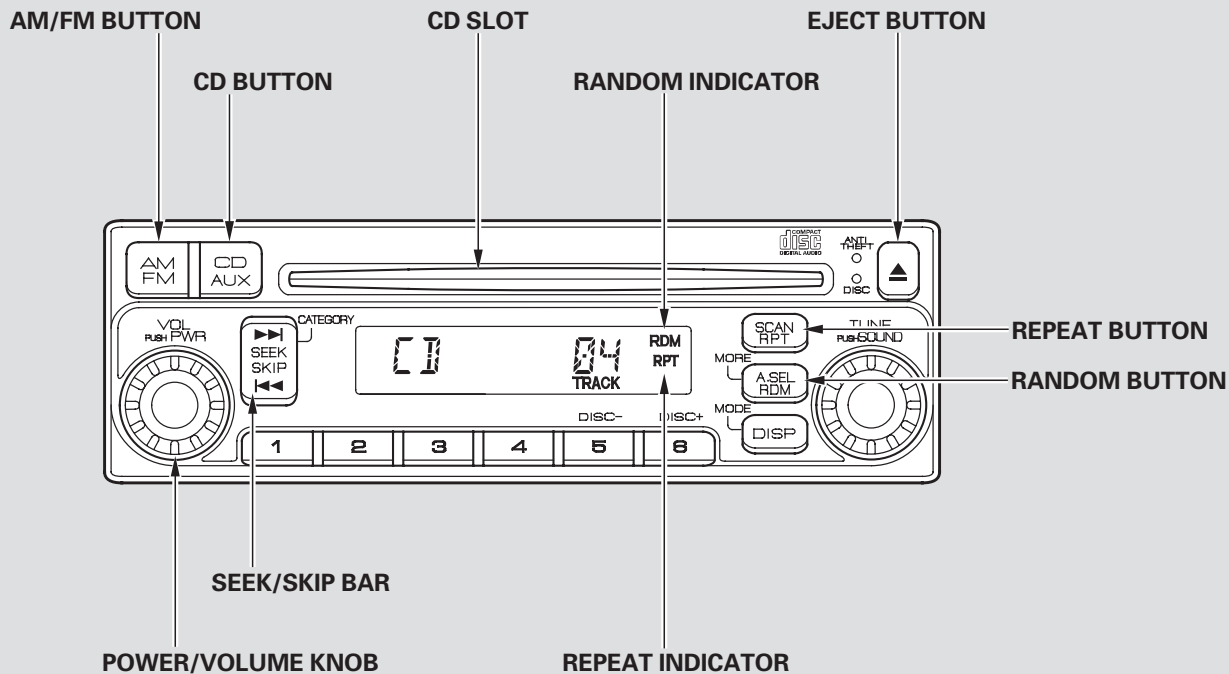

## To Play a CD

With the ignition switch in the ACCESSORY (I) or ON (II) position, insert a CD into the CD slot. The drive will pull the CD in the rest of the way and begin to play it. The number of the track playing is shown in the display. The system will continuously play a CD until you change modes.

### NOTICE

*Do not use discs with adhesive labels. The label can curl up and cause the disc to jam in the unit.*

**SKIP** — Each time you press and release the ►► side of the skip bar, the player skips forward to the beginning of the next track. Press and release the ◄◄ side of the bar to skip backward to the beginning of the current track. Press it again to skip to the beginning of the previous track.

To move rapidly within a track, press and hold the ►► or ◄◄ side. You will see CUE or REW in the display.

**REPEAT** — To continuously replay a track, press and release the RPT button. You will see RPT in the display. Press it again to turn it off.

**RANDOM** — This feature plays the tracks in random order. To activate Random Play, press and release the RDM button. You will see RDM in the display. Press it again to return to normal play.

## To Stop Playing a CD

Press the eject button ( ▲ ) to remove the CD. If you eject the CD, but do not remove it from the slot, the system will automatically reload the CD after 15 seconds and put it in pause mode. To begin playing, press the CD button.

Press the AM/FM button to switch to the radio while a CD is playing.

If you turn the system off while a CD is playing, either with the PWR/VOL knob or by turning off the ignition switch, the CD will stay in the drive. When you turn the system back on, the CD will begin playing where it left off.

## CD Changer, Protecting Your CDs

---

### Operating the Optional CD Changer

An optional six disc CD changer is available for your vehicle. This CD changer uses the same controls used for the in-dash CD player.

Load the desired CDs in the magazine, and load the magazine in the changer according to the instructions that came with the unit.

To select the CD changer, press the CD button. The CD and track numbers will be displayed. To select a different CD, use the preset 5 (DISC -) or preset 6 (DISC +) button. If you select an empty slot in the magazine, the changer will, after finding that slot empty, try to load the CD in the next slot.

### Protecting Your CDs

#### *General Information*

- When using CD-R discs, use only high quality CDs labeled for audio use.
- When recording a CD-R, the recording must be closed for it to be used by the system.
- CD-RW discs will not work in this unit.
- Play only standard round CDs. Odd-shaped CDs may jam in the drive or cause other problems.
- Handle your CDs properly to prevent damage and skipping.

#### *Protecting CDs*

When a CD is not being played, store it in its case to protect it from dust and other contamination. To prevent warpage, keep CDs out of direct sunlight and extreme heat.

To clean a CD, use a clean soft cloth. Wipe across the CD from the center to the outside edge.

A new CD may be rough on the inner and outer edges. The small plastic pieces causing this roughness can flake off and fall on the recording surface of the CD, causing skipping or other problems. Remove these pieces by rubbing the inner and outer edges with the side of a pencil or pen.

Never try to insert foreign objects in the CD player or the magazine.

# Protecting Your CDs, CD Player Error Messages

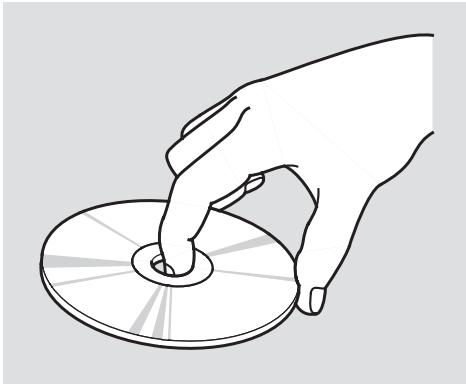

Handle a CD by its edges; never touch either surface. Do not place stabilizer rings or labels on the CD. These, along with contamination from fingerprints, liquids, and felt-tip pens, can cause the CD to not play properly, or possibly jam in the drive.

## CD Player Error Messages

If you see an error message in the display while playing a CD, find the cause in the chart to the right. If you cannot clear the error message, take the vehicle to your dealer.

Error Message	Cause	Solution
CD DISC	FOCUS Error	Press the EJECT button and pull out the CD. Check if the CD is inserted correctly in the CD player. Make sure the CD is not scratched or damaged.
CD ERR	Mechanical Error	Press the EJECT button and pull out the CD. Check the CD for damage or deformation. If the CD cannot be pulled out or the error message does not disappear after the CD is ejected, see your dealer. Do not try to force the disc out of the player.
CD Hot	High temperature	Will disappear when the temperature returns to normal.

## CD Changer Error Messages

If you see an error message in the display while playing a CD, find the cause in the chart to the right. If you cannot clear the error message, take the vehicle to your dealer.

Error Message	Cause	Solution
CD DISC	FOCUS Error	Press the magazine eject button and pull out the magazine, check for error message. Insert the magazine again. If the error message does not disappear or the magazine cannot be pulled out, consult your dealer.
	No CD in the CD magazine	Insert CD.
CD ERR	Mechanical Error	Press the magazine eject button and pull it out. Check for error message, and insert the magazine again. If the error message does not disappear or the magazine cannot be pulled out, see your dealer.
CD HOT	High temperature	Will disappear when the temperature returns to normal.
CD EJECT	No CD magazine in the CD changer	Insert CD magazine.

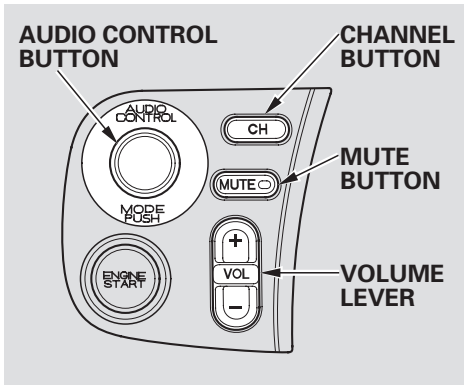

Four controls for the audio system are on the left side of the dashboard by the instrument panel. These let you control basic functions without distracting your attention from driving.

Use the VOLUME lever to adjust the volume. Push the lever up to increase the volume and down to decrease it. Hold the lever until the volume reaches the desired level, then release it.

If you want to mute the sound temporarily, push the MUTE button. The indicator in the button will come on to indicate the mute function is on. Press the button again to cancel MUTE.

The AUDIO CONTROL button changes the mode. Pressing the button repeatedly selects AM, FM1, FM2, or CD (if a CD is loaded), XM1, XM2 (if you have the optional satellite radio feature).

The CHANNEL button has two functions, depending on whether you are listening to the radio, or playing a CD.

If you are listening to the radio, use the CHANNEL button to change stations. Each time you press this button, the system advances to the next preset station on the band you are listening to. You will see the number of the selected preset button

in the audio system display.

If you are playing a CD, the system skips to the beginning of the next track each time you push the CHANNEL button.

These controls work only with the factory-installed audio system. They will not function if you install any other system.

## Radio Theft Protection

---

Your vehicle's audio system will disable itself if it is disconnected from electrical power for any reason. To make it work again, you must enter a specific five-digit code in the preset buttons. Because there are hundreds of number combinations possible from five digits, making the system work without knowing the exact code is nearly impossible.

You should have received a card that lists your audio system's code and serial numbers. It is best to store this card in a safe place at home. In addition, you should write the audio system's serial number in this Owner's Manual.

If you lose the card, you must obtain the code number from a dealer. To do this, you will need the system's serial number.

If your vehicle's battery is disconnected or goes dead, or the radio fuse is removed, the audio system will disable itself. If this happens, you will see "Code" in the frequency display the next time you turn on the system. Use the preset buttons to enter the five-digit code. The code is on the radio code card included in your Owner's Manual kit. When it is entered correctly, the radio will start playing.

If you make a mistake entering the code, do not start over; complete the five-digit sequence, then enter the correct code. You have ten tries to enter the correct code. If you are unsuccessful in ten attempts, you must then leave the system on for 1 hour before trying again.

You will have to store your favorite stations in the preset buttons after the system begins working. Your original settings were lost when the power was disconnected.



Cruise control allows you to maintain a set speed above 25 mph (40 km/h) without keeping your foot on the accelerator pedal. It should be used for cruising on straight, open highways. It is not recommended for city driving, winding roads, slippery roads, heavy rain, or bad weather.

## **⚠ WARNING**

Improper use of the cruise control can lead to a crash.

Use the cruise control only when traveling on open highways in good weather.

## **NOTICE**

*The cruise control, as it operates, moves the accelerator pedal. You can damage your vehicle's accelerator mechanism by resting your foot under the pedal and blocking the movement.*

## Using the Cruise Control

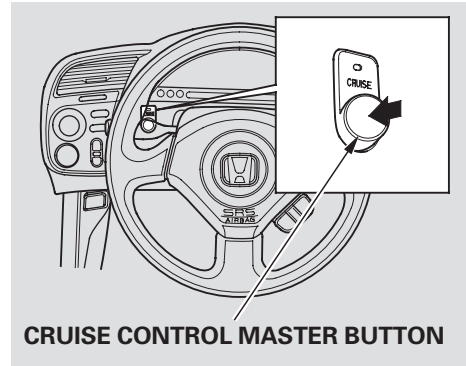

1. Push in the Cruise Control Master Button. The indicator will come on.
2. Accelerate to the desired cruising speed above 25 mph (40 km/h).

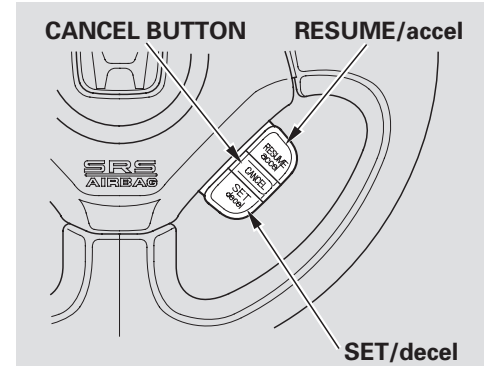

3. Press and release the SET/deccl button on the steering wheel. The indicator on the instrument panel comes on to show the system is now activated.

CONTINUED

## Cruise Control

---

Cruise control may not hold the set speed when you are going up and down hills. If your speed increases going down a hill, use the brakes to slow down. This will cancel the cruise control. To resume the set speed, press the RESUME/accel button. The indicator on the instrument panel will come back on.

### Changing the Set Speed

You can increase the set cruising speed in any of these ways:

- Press and hold the RESUME/accel button. When you reach the desired cruising speed, release the button.
- Push on the accelerator pedal. Accelerate to the desired cruising speed, and press the SET/decel button.
- To increase the speed in very small amounts, tap the RESUME/accel button. Each time you do this, your vehicle speeds up about 1 mph (1.6 km/h).

You can decrease the set cruising speed in any of these ways:

- Press and hold the SET/decel button. Release the button when you reach the desired speed.
- To slow down in very small amounts, tap the SET/decel button. Each time you do this, your vehicle will slow down about 1 mph (1.6 km/h).
- Tap the brake or clutch pedal lightly with your foot. The CRUISE CONTROL indicator on the instrument panel goes out. When the vehicle slows to the desired speed, press the SET/decel button.

Even with the cruise control turned on, you can still use the accelerator pedal to speed up for passing. After completing the pass, take your foot off the accelerator pedal. The vehicle will return to the set cruising speed.

Resting your foot on the brake or clutch pedal causes the cruise control to cancel.

## **Cancelling the Cruise Control**

You can cancel the cruise control in any of these ways:

- Tap the brake or clutch pedal.
- Push the CANCEL button on the steering wheel.
- Push the Cruise Control Master Button.

## **Resuming the Set Speed**

When you push the CANCEL button, or tap the brake or clutch pedal, the system will remember the previously set cruising speed. To return to that speed, accelerate to above 25 mph (40 km/h) and then press and release the RESUME/accel button. The CRUISE CONTROL indicator comes on. The vehicle will accelerate to the same cruising speed as before.

Pressing the Cruise Control Master Button turns the system off and erases the previous cruising speed.



Before you begin driving your vehicle, you should know what gasoline to use, and how to check the levels of important fluids. You also need to know how to properly store luggage or packages. The information in this section will help you. If you plan to add any accessories to your vehicle, please read the information in this section first.

Break-in Period .....	100
Fuel Recommendation .....	100
Service Station Procedures .....	101
Refueling.....	101
Opening and Closing the Hood.....	102
Oil Check.....	103
Engine Coolant Check .....	104
Fuel Economy .....	104
Accessories and Modifications ....	105
Carrying Cargo .....	107

## Break-in Period, Fuel Recommendation

---

### Break-in Period

Help assure your vehicle's future reliability and performance by paying extra attention to how you drive during the first 600 miles (1,000 km).

During this period:

- Avoid full-throttle starts and rapid acceleration. Do not exceed 5,500 rpm for the first 600 miles (1,000 km) of operation.
- Do not change the oil until the scheduled maintenance time.
- Avoid hard braking for the first 200 miles (300 km).

You should also follow these recommendations with an overhauled or exchanged engine, or when the brakes are replaced.

### Fuel Recommendation

Your vehicle is designed to operate on premium unleaded gasoline with a pump octane of 91 or higher. Use of a lower octane gasoline can cause occasional metallic knocking noises in the engine and will result in decreased engine performance. Use of a gasoline with a pump octane less than 86 can lead to engine damage.

We recommend quality gasoline containing detergent additives that help prevent fuel system and engine deposits.

In addition, in order to maintain good performance, fuel economy, and emissions control, we strongly recommend, in areas where it is available, the use of gasoline that does NOT contain manganese-based fuel additives such as MMT.

Use of gasoline with these additives may adversely affect performance,

and cause the Malfunction Indicator Lamp on your instrument panel to come on. If this happens, contact your authorized dealer for service.

Some gasoline today is blended with oxygenates such as ethanol or MTBE. Your vehicle is designed to operate on oxygenated gasoline containing up to 10 percent ethanol by volume and up to 15 percent MTBE by volume. Do not use gasoline containing methanol.

If you notice any undesirable operating symptoms, try another service station or switch to another brand of gasoline.

For further important fuel-related information, please refer to your **Quick Start Guide**.

## Refueling

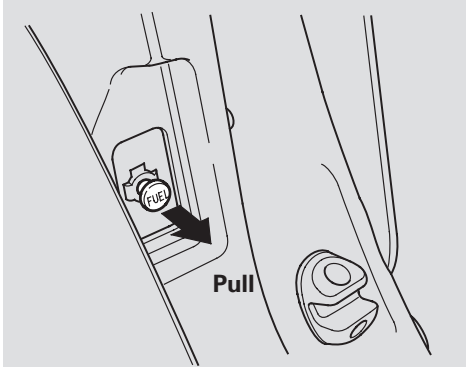

1. Park with the driver's side closest to the service station pump.
2. Open the fuel fill door by pulling on the knob on the driver's door jamb.

## **⚠ WARNING**

Gasoline is highly flammable and explosive. You can be burned or seriously injured when handling fuel.

- Stop the engine and keep heat, sparks, and flame away.
- Handle fuel only outdoors.
- Wipe up spills immediately.

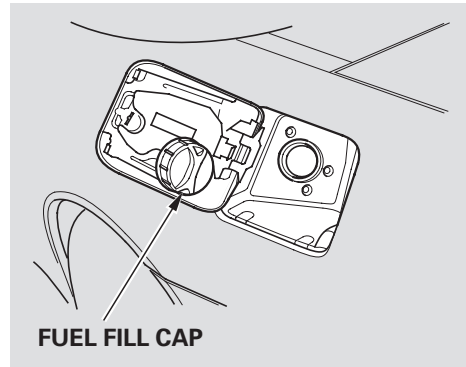

3. Remove the fuel fill cap slowly. You may hear a hissing sound as pressure inside the tank escapes. Place the cap in the holder on the fuel fill door.
4. Stop filling the tank after the fuel nozzle automatically clicks off. Do not try to "top off" the tank. Leave some room for the fuel to expand with temperature changes.

*If the fuel nozzle keeps clicking off even though the tank is not full, there may be a problem with your vehicle's fuel vapor recovery system. The system helps keep fuel vapors from going into the atmosphere. Try filling at another pump. If this does not fix the problem, consult your dealer.*

CONTINUED

## Service Station Procedures

5. Screw the fuel fill cap back on until it clicks at least three times. If you do not properly tighten the cap, the Malfunction Indicator Lamp may come on (see page 171).
6. Push the fuel fill door closed until it latches.

### Opening and Closing the Hood



1. Park the vehicle, and set the parking brake. Pull the hood release handle located under the lower left corner of the dashboard. The hood will pop up slightly.
2. Put your fingers under the front edge of the hood near the center. Slide your hand to the left until you feel the hood latch handle. Push this handle to the left to release the hood. Lift up the hood.

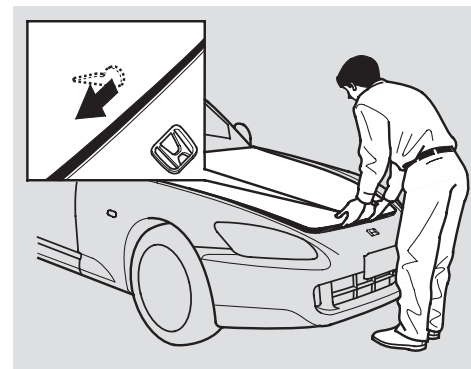

- If the hood latch handle moves stiffly, or if you can open the hood without lifting the handle, the mechanism should be cleaned and lubricated.
3. Pull the support rod out of its clip and insert the end into the designated hole in the hood.



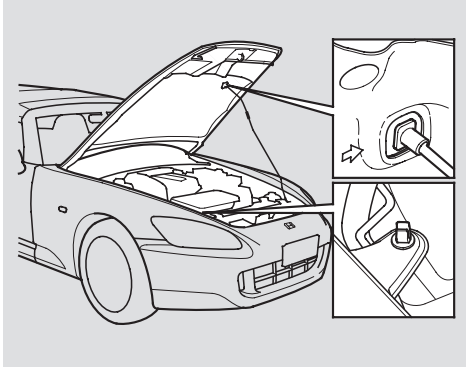

To close the hood, lift it up slightly to remove the support rod from the hole. Put the support rod back into its holding clip. Lower the hood to about a foot (30 cm) above the fender, then let it drop. Make sure it is securely latched.

## Oil Check

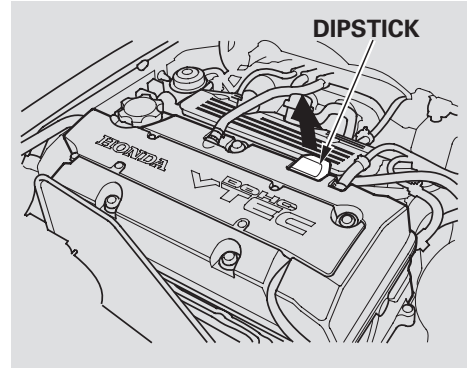

Wait a few minutes after turning the engine off before you check the oil.

1. Remove the dipstick (black handle).
2. Wipe off the dipstick with a clean cloth or paper towel.
3. Insert it all the way back in its hole.

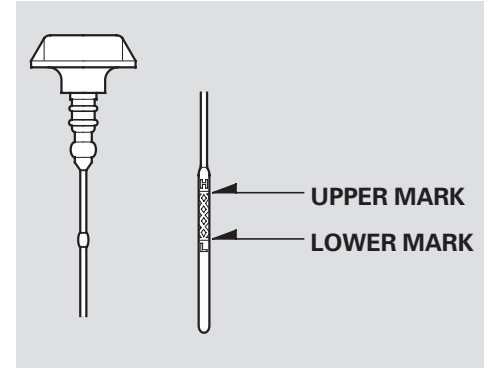

4. Remove the dipstick again and check the level. It should be between the upper and lower marks.

If it is near or below the lower mark, see **Adding Engine Oil** on page [131](#).

# Service Station Procedures, Fuel Economy

---

## Engine Coolant Check

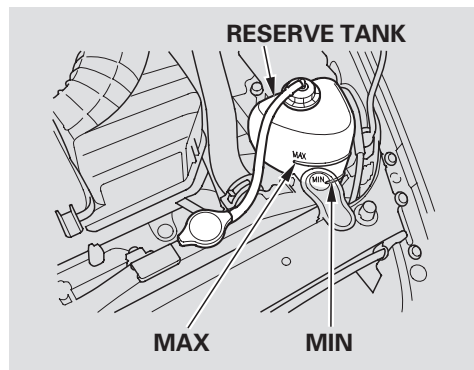

Look at the coolant level in the radiator reserve tank. Make sure it is between the MAX and MIN lines. If it is below the MIN line, see **Adding Engine Coolant** on page [134](#) for information on adding the proper coolant.

Refer to **Owner's Maintenance Checks** on page [124](#) for information about checking other items on your vehicle.

## Fuel Economy *Improving Fuel Economy*

- Always maintain your vehicle according to the maintenance schedule. See **Owner's Maintenance Checks** on page [124](#).

*For example, an underinflated tire causes more “rolling resistance,” which uses more fuel.*

The build-up of snow or mud on your vehicle's underside adds weight and rolling resistance. Frequent cleaning helps your fuel mileage and reduces the chance of corrosion.

- Drive moderately. Rapid acceleration, abrupt cornering, and hard braking use more fuel.
- Always drive in the highest gear possible.

- Try to maintain a constant speed. Every time you slow down and speed up, your vehicle uses extra fuel. Use the cruise control when appropriate.
- Combine several short trips into one.
- The air conditioning puts an extra load on the engine which makes it use more fuel. Use the fresh-air ventilation when possible.

Modifying your vehicle, or installing some non-Honda accessories, can make your vehicle unsafe. Before you make any modifications or add any accessories, be sure to read the following information.

### Accessories

Your dealer has Honda accessories that allow you to personalize your vehicle. These accessories have been designed and approved for your vehicle, and are covered by warranty.

Although non-Honda accessories may fit on your vehicle, they may not meet factory specifications, and could adversely affect your vehicle's handling and stability.

### **WARNING**

Improper accessories or modifications can affect your vehicle's handling, stability, and performance, and cause a crash in which you can be hurt or killed.

Follow all instructions in this owner's manual regarding accessories and modifications.

When properly installed, cellular phones, alarms, two-way radios, and low-powered audio systems should not interfere with your vehicle's computer controlled systems, such as your airbags and anti-lock brakes.

Before installing any accessory:

- Make sure the accessory does not obscure any lights, or interfere with proper vehicle operation or performance.
- Be sure electronic accessories do not overload electrical circuits (see page 174 ) or interfere with proper operation.
- Before installing any electronic accessory, have the installer contact your dealer. If possible, have your dealer inspect the final installation.

## Accessories and Modifications

---

### Modifying Your Vehicle

Removing parts from your vehicle, or replacing components with non-Honda components could seriously affect your vehicle's handling, stability, and reliability.

Some examples are:

- Lowering the vehicle with a non-Honda suspension kit that significantly reduces ground clearance can allow the undercarriage to hit speed bumps or other raised objects, which could cause the airbags to deploy.
- Raising your vehicle with a non-Honda suspension kit can affect the handling and stability.
- Non-Honda wheels, because they are a universal design, can cause excessive stress on suspension components.

- Larger or smaller wheels and tires can interfere with the operation of your vehicle's anti-lock brakes and other systems.
- Modifying your steering wheel or any other part of your vehicle's safety systems could make the systems ineffective.

If you plan to modify your vehicle, consult your dealer.

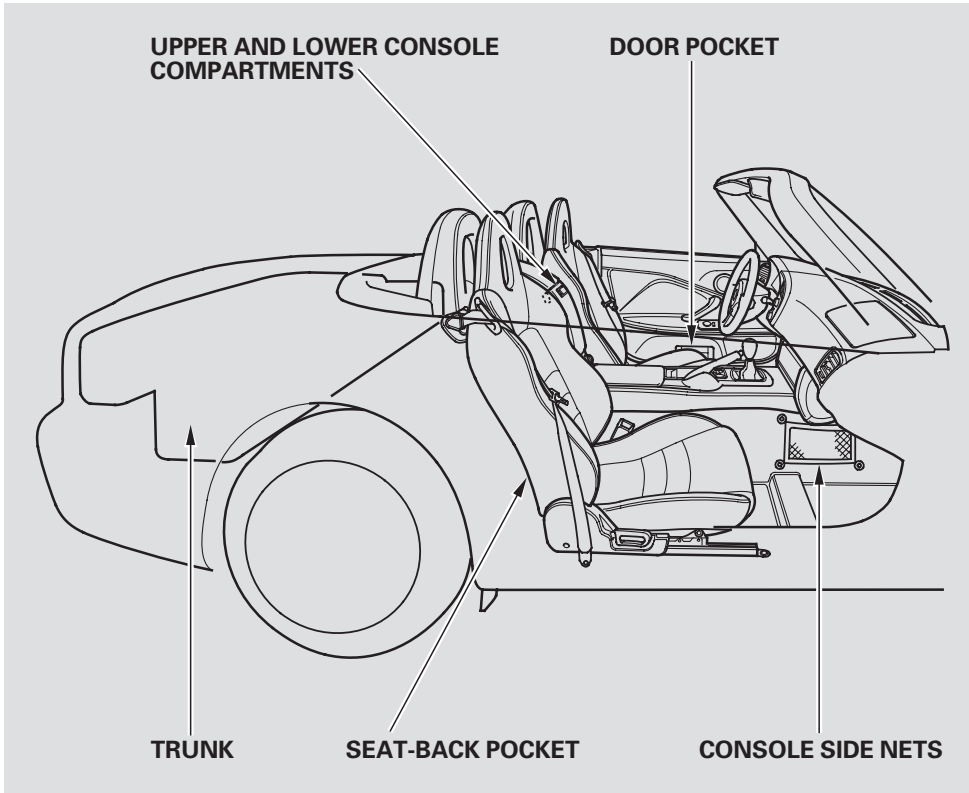

Your vehicle has several convenient storage areas:

- Upper and lower console compartments
- Door pockets
- Console Side Nets
- Seat-back pockets
- Trunk

However, carrying too much cargo, or improperly storing it, can affect your vehicle's handling, stability, stopping distance, and tires, which may make it unsafe. Before carrying any type of cargo, be sure to read the following pages.

# Carrying Cargo

---

## Load Limits

The maximum load for your vehicle is 400 lbs (185 kg). This figure includes the total weight of all occupants, cargo, and accessories.

### **WARNING**

Overloading or improper loading can affect handling and stability and cause a crash in which you can be hurt or killed.

Follow all load limits and other loading guidelines in this manual.

## Steps for Determining Correct Load Limit:

1. Locate the statement, “the combined weight of occupants and cargo should never exceed 400 lbs” on your vehicle’s placard. [The placard is on the driver’s doorjamb.]
2. Determine the combined weight of the driver and passenger that will be riding in your vehicle.
3. Subtract the combined weight of the driver and passenger from 400 pounds or 185 kilograms.
4. The resulting figure equals the available amount of cargo and luggage load capacity. For example, if the maximum load is 400 lbs and there will be two 150 lb. passengers in your vehicle, the amount of available cargo and luggage load capacity is 100 lbs. [400 – 300 (2 × 150) = 100 lbs.]
5. Determine the combined weight of luggage and cargo being loaded on the vehicle. That weight may not safely exceed the available cargo and luggage load capacity in Step 4.

In addition, the total weight of the vehicle, all passengers, accessories, and cargo must not exceed the Gross Vehicle Weight Rating (GVWR) or the Gross Axle Weight Rating (GAWR). Both are on a label on the driver’s doorjamb.

## Carrying Items in the Passenger Compartment

- Store or secure all items that could be thrown around and hurt someone during a crash.
- Be sure items placed on the floor behind the seats cannot roll under the seats and interfere with the driver's ability to operate the pedals or the proper operation of the seats.

## Carrying Cargo in the Trunk

- Distribute cargo evenly on the floor of the trunk, placing the heaviest items on the bottom and as far forward as possible.





This section gives you tips on starting the engine under various conditions, and how to operate the manual transmission. It also includes important information on parking your vehicle, and the braking system.

Driving Guidelines.....	112
Preparing to Drive .....	113
Starting the Engine.....	114
Manual Transmission.....	115
Parking.....	117
Braking System.....	117
Anti-lock Brakes (ABS) .....	118
Towing a Trailer .....	119

## Driving Guidelines

---

Your vehicle is designed to give you optimum handling and performance on well-maintained roads. As part of this design, your vehicle has a minimum of ground clearance and very low-profile tires.

- Use caution if you ever drive your vehicle on very rough or rutted roads. You could damage the suspension and underbody by bottoming out. Going too fast over parking lot “speed bumps” can also cause damage.

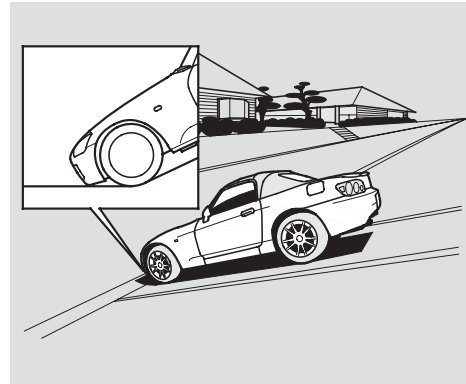

- Curbs and steep inclines could damage the front and rear bumpers. Low curbs that do not affect the average vehicle may be high enough to hit the bumper on your vehicle. The front or rear bumper may scrape when trying to drive onto an incline, such as a steep driveway or trailer ramps.

- Because of the low-profile tires fitted to your vehicle, the alloy wheels are closer to the ground. Driving over a pothole or road debris at too high a speed can seriously damage a wheel. Slow down under these conditions.

You should do the following checks and adjustments before you drive your vehicle.

1. Make sure all windows, mirrors, and outside lights are clean and unobstructed. Remove frost, snow, or ice.
2. Check that the hood is fully closed.
3. Check that the trunk is fully closed.
4. Visually check the tires. If a tire looks low, use a gauge to check its pressure.
5. Check that any items you may be carrying are stored properly or fastened down securely.
6. Check the seat adjustment (see page 58 ).
7. Check the adjustment of the inside and outside mirrors (see page 66 ).
8. Make sure the doors are securely closed and locked.
9. Fasten your seat belt. Check that your passenger has fastened his or her seat belt (see page 12 ).
10. When you start the engine, check the gauges and indicators in the instrument panel (see page 39 ).

## Starting the Engine

---

1. Apply the parking brake.
2. In cold weather, turn off all electrical accessories to reduce the drain on the battery.
3. Push the clutch pedal down all the way. The ENGINE START button has no effect unless the clutch pedal is pressed.
4. Turn the ignition key to the ON (II) position.
5. Without touching the accelerator pedal, push the ENGINE START button. Do not hold the ENGINE START button for more than 15 seconds at a time. If the engine does not start right away, pause for at least 10 seconds before trying again.

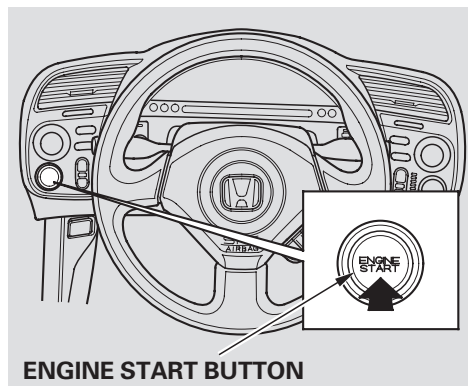

### NOTICE

*The Immobilizer System protects your vehicle from theft. If an improperly-coded key (or other device) is used, the engine's fuel system is disabled. See **Immobilizer System** on page 52.*

6. If the engine does not start within 15 seconds, or starts but stalls right away, repeat step 5 with the accelerator pedal pressed halfway down. If the engine starts, release pressure on the accelerator pedal so the engine does not race.
7. If the engine fails to start, press the accelerator pedal all the way down and hold it there while starting to clear flooding. If the engine still does not start, return to step 6.

### NOTICE

*The engine is harder to start in cold weather. Also, the thinner air found at altitudes above 8,000 feet (2,400 meters) adds to this problem.*

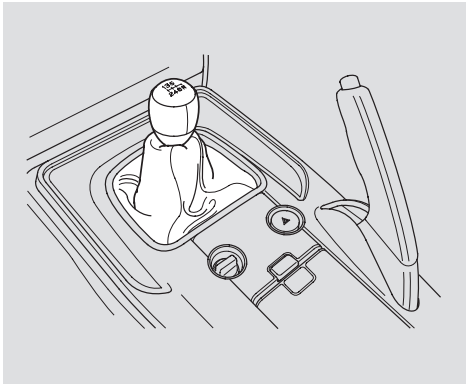

The manual transmission is synchronized in all forward gears for smooth operation. It has a lockout so you cannot shift directly from Fifth to Reverse instead of Sixth (see page 116). When shifting up or down, make sure you push the clutch pedal down all the way, shift to the next gear, and let the pedal up gradually. When you are not shifting, do not rest your foot on the clutch pedal. This can cause your clutch to wear out faster.

Come to a full stop before you shift into Reverse. You can damage the transmission by trying to shift into Reverse with the vehicle moving. Push down the clutch pedal, and pause for a few seconds before shifting into Reverse, or shift into one of the forward gears for a moment. This stops the gears so they won't "grind."

When slowing down, you can get extra braking from the engine by shifting to a lower gear. This extra braking can help you maintain a safe speed and prevent your brakes from overheating while going down a steep hill. Before downshifting, make sure the engine speed will not go into the tachometer's red zone in the lower gear.

## **⚠️ WARNING**

Rapid slowing or speeding-up can cause loss of control on slippery surfaces. If you crash, you can be injured.

Use extra care when driving on slippery surfaces.

Your vehicle is equipped with an aluminum shift lever. If you leave the vehicle parked outside for a long time on a hot day, be careful before moving the shift lever. Because of the heat, the shift lever may be extremely hot. If the outside temperature is low, the shift lever feels cold.

# Manual Transmission

## Recommended Shift Points

Drive in the highest gear that lets the engine run and accelerate smoothly. This will give you good fuel economy and effective emissions control. The following shift points are recommended:

Shift Up	Normal Acceleration
1st to 2nd	15 mph (24 km/h)
2nd to 3rd	25 mph (40 km/h)
3rd to 4th	40 mph (64 km/h)
4th to 5th	47 mph (75 km/h)
5th to 6th	52 mph (83 km/h)

## Engine Speed Limiter

If you exceed the maximum speed for the gear you are in, the engine speed will enter into the tachometer's red zone. If this occurs, you may feel the engine cut in and out. This is caused by a limiter in the engine's computer controls. The engine will run normally when you reduce the RPM below the red zone.

Before downshifting, make sure the engine will not go into the tachometer's red zone.

## Reverse Lockout



The manual transmission has a lockout so you cannot accidentally shift from Fifth to Reverse instead of Sixth while the vehicle is moving.

With the clutch pedal pressed, move the shift lever to the Reverse side of the Neutral gate. Then push the shift lever down, and shift to Reverse.

## Parking

Always use the parking brake when you park your vehicle. Make sure the parking brake is set firmly or your vehicle may roll if it is on an incline.

## Parking Tips

- Make sure the convertible top and the windows are closed.
- Turn off the lights.
- Place any packages, valuables, etc., in the trunk or take them with you.
- Lock the doors.
- Never park over dry leaves, tall grass, or other flammable materials. The hot three way catalytic converter could cause these materials to catch on fire.

- If the vehicle is facing uphill, turn the front wheels away from the curb, and put the transmission in first gear.
- If the vehicle is facing downhill, turn the front wheels toward the curb, and put the transmission in reverse gear.
- Make sure the parking brake is fully released before driving away. Driving with the parking brake partially set can overheat or damage the rear brakes.

## Braking System

Your vehicle is equipped with disc brakes at all four wheels. A power assist helps reduce the effort needed on the brake pedal. The ABS helps you retain steering control when braking very hard.

Resting your foot on the pedal keeps the brakes applied lightly, builds up heat, and reduces their effectiveness. It also keeps your brake lights on all the time, confusing drivers behind you.

Constant application of the brakes when going down a long hill builds up heat and reduces their effectiveness. Use the engine to assist the brakes by taking your foot off the accelerator and downshifting to a lower gear.

*CONTINUED*

## Braking System, Anti-lock Brakes (ABS)

---

Check the brakes after driving through deep water. Apply the brakes moderately to see if they feel normal. If not, apply them gently and frequently until they do. Be extra cautious in your driving.

### **Braking System Design**

The hydraulic system that operates the brakes has two separate circuits. Each circuit works diagonally across the vehicle (the left-front brake is connected with the right-rear brake, etc.). If one circuit should develop a problem, you will still have braking at two wheels.

### **Brake Wear Indicators**

If the brake pads need replacing, you will hear a distinctive, metallic screeching sound when you apply the brake pedal. If you do not have the brake pads replaced, they will screech all the time. It is normal for the brakes to occasionally squeal or squeak when you apply them.

### **Anti-lock Brakes (ABS)**

The Anti-lock Brake System (ABS) helps prevent the brakes from locking up and helps you retain steering control by pumping the brakes rapidly; much faster than a person.

*You should never pump the brake pedal. Let the ABS work for you by always keeping firm, steady pressure on the brake pedal. This is sometimes referred to as “stomp and steer.”*

You will feel a pulsation in the brake pedal when the ABS activates, and may hear some noise. This is normal: it is the ABS rapidly pumping the brakes. On dry pavement, you will need to press on the brake pedal very hard before the ABS activates. However, you may feel the ABS activate immediately if you are trying to stop on snow or ice.



## ABS Indicator

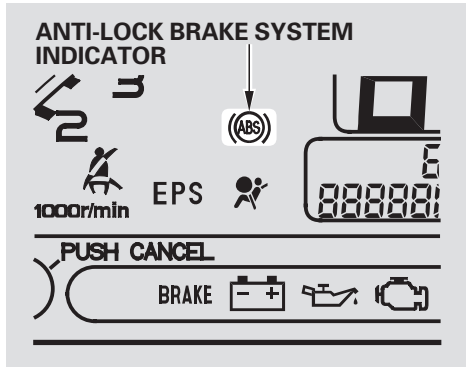

If the ABS indicator comes on, the anti-lock function of the braking system has shut down. The brakes still work like a conventional system, but without anti-lock. You should have your dealer inspect your vehicle as soon as possible.

## Important Safety Reminders

**ABS does not reduce the time or distance it takes to stop the vehicle;** it only helps with steering control during braking.

**ABS will not prevent a skid that results from changing direction abruptly,** such as trying to take a corner too fast or making a sudden lane change.

**ABS cannot prevent a loss of stability.** Always steer moderately when you are braking hard. Severe or sharp steering wheel movement can still cause your vehicle to veer into oncoming traffic or off the road.

**A vehicle with ABS may require a longer distance to stop** on loose or uneven surfaces, such as gravel or snow, than a vehicle without anti-lock.

## Towing a Trailer

Your vehicle is not designed to tow a trailer, attempting to do so can void your warranties.



This section explains why it is important to keep your vehicle well maintained and how to follow basic maintenance safety precautions.

This section also includes Maintenance Schedules for normal driving and severe driving conditions, a Maintenance Record, and instructions for simple maintenance tasks you may want to take care of yourself.

If you have the skills and tools to perform more complex maintenance tasks on your vehicle, you may want to purchase the Service Manual. See page 197 for information on how to obtain a copy, or see your dealer.

Maintenance Safety.....	122
Maintenance Schedule.....	123
Maintenance Record.....	127
Fluid Locations.....	130
Adding Engine Oil.....	131
Changing the Oil and Filter.....	132
Engine Coolant.....	134
Windshield Washers.....	136
Manual Transmission Fluid.....	137
Differential Fluid.....	138
Brake and Clutch Fluid.....	139
Lights.....	140
Cleaning the Seat Belts.....	145
Floor Mats.....	146
Dust and Pollen Filter.....	146
Wiper Blades.....	147
Tires.....	148
Checking the Battery.....	154
Vehicle Storage.....	155

# Maintenance Safety

---

All service items not detailed in this section should be performed by a certified technician or other qualified mechanic.

## Important Safety Precautions

To eliminate potential hazards, read the instructions before you begin, and make sure you have the tools and skills required.

- Make sure your vehicle is parked on level ground, the parking brake is set, and the engine is off.
- To clean parts, use a commercially available degreaser or parts cleaner, not gasoline.
- To reduce the possibility of fire or explosion, keep cigarettes, sparks, and flames away from the battery and all fuel-related parts.
- Wear eye protection and protective clothing when working with the battery or compressed air.

## ⚠ WARNING

Improperly maintaining this vehicle or failing to correct a problem before driving can cause a crash in which you can be seriously hurt or killed.

Always follow the inspection, maintenance recommendations, and schedules in this owner's manual.

## Potential Vehicle Hazards

- **Carbon Monoxide poison from engine exhaust.** Be sure there is adequate ventilation whenever you operate the engine.
- **Burns from hot parts.** Let the engine and exhaust system cool before touching any parts.

- **Injury from moving parts.** Do not run the engine unless instructed to do so.

## ⚠ WARNING

Failure to properly follow maintenance instructions and precautions can cause you to be seriously hurt or killed.

Always follow the procedures and precautions in this owner's manual.

Some of the most important safety precautions are given here. However, we cannot warn you of every conceivable hazard that can arise in performing maintenance. Only you can decide whether or not you should perform a given task.

The maintenance schedule assumes you will use your vehicle as normal transportation for your passenger and possessions. You should also follow these recommendations:

- Avoid exceeding your vehicle's load limit. This puts excess stress on the engine, brakes, and many other vehicle parts. The load limit is shown on the tire information label on the driver's doorjamb.
- Operate your vehicle on reasonable roads within the legal speed limit.
- Drive your vehicle regularly over a distance of several miles (kilometers).
- Always use unleaded gasoline with the proper octane rating (see page [100](#)).

## Which Schedule to Follow

Service your vehicle according to the time and mileage periods on one of the Maintenance Schedules on the following pages.

**U.S. Owners** — Follow the Maintenance Schedule for Severe Conditions if you drive your vehicle **MAINLY** under one or more of the following conditions.

- Driving less than 5 miles (8 km) per trip or, in freezing temperatures, driving less than 10 miles (16 km) per trip.
- Driving in extremely hot [over 90°F (32°C)] conditions.
- Extensive idling or long periods of stop and go driving.

- Driving in mountainous conditions.
- Driving on muddy, dusty, or de-iced roads.

**NOTE:** If you only **OCCASIONALLY** drive under a “severe” condition, you should follow the Maintenance Schedule for Normal Conditions.

**Canadian Owners** — Follow the Maintenance Schedule for Severe Conditions.

# Maintenance Schedule

---

## Servicing Your Vehicle

Your authorized dealer knows your vehicle best and can provide competent, efficient service. However, service at a dealer is not mandatory to keep your warranties in effect. Maintenance may be done by any qualified service facility or skilled person to keep your warranties in effect. Keep all the receipts as proof of completion, and have the person who does the work fill out the Maintenance Record. Check your warranty booklet for more information.

We recommend the use of Honda parts and fluids whenever you have maintenance done.

U.S. Vehicles:

**Maintenance, replacement, or repair of emissions control devices and systems may be done by any automotive repair establishment or individual using parts that are “certified” to EPA standards.**

According to state and federal regulations, failure to perform maintenance on the items marked with # will not void your emissions warranties. However, all maintenance services should be performed at the recommended time or mileage period to ensure long-term reliability.

## Owner’s Maintenance Checks

You should check the following items at the specified intervals. If you are unsure of how to perform any check, turn to the appropriate page listed.

- Engine oil level — Check every time you fill the fuel tank. See page [103](#).
- Engine coolant level — Check the radiator reserve tank every time you fill the fuel tank. See page [104](#).
- Brakes and clutch — Check the fluid level monthly. See page [139](#).
- Tires — Check the tire pressure monthly. Examine the tread for wear and foreign objects. See page [148](#).
- Lights — Check the operation of the headlights, parking lights, taillights, high-mount brake light, and license plate lights monthly. See page [140](#).

Service the items listed at the indicated distance (or time, if given).											
	miles x 1,000	15	30	45	60	75	90	105	120	135	150
	km x 1,000	24	48	72	96	120	144	168	192	216	240
Check engine oil and coolant	Check oil and coolant at each fuel stop										
Check tires	Check inflation and condition once a month or every 7,500 miles (12,000 km), whichever comes first										
Replace engine oil	Every 7,500 miles (12,000 km) or every 1 year, whichever comes first										
Replace engine oil filter	Every 15,000 miles (24,000 km) or every 1 year, whichever comes first										
Check front and rear brakes											
Check parking brake adjustment											
Inspect the following items:											
Tie-rod ends, steering gearbox, and boots											
Suspension components											
Driveshaft boots											
Brake hoses and lines (including ABS)	Every 30,000 miles (48,000 km) or every 2 years, whichever comes first										
All fluid levels and condition of fluids											
Exhaust system <sup>#</sup>											
Fuel lines and connections <sup>#</sup>											
Inspect drive belts	Every 30,000 miles (48,000 km) or every 2 years, whichever comes first										
Replace dust and pollen filter											
Replace air cleaner element		●			●		●		●		●
Replace spark plugs							●		●		
Inspect valve clearance	Inspect every 105,000 miles (168,000 km), otherwise adjust only if noisy										
Replace manual transmission fluid	Every 120,000 miles (192,000 km) or every 6 years, whichever comes first										
Replace rear differential fluid	Every 30,000 miles (48,000 km) or every 2 years, whichever comes first										
Inspect idle speed								●			
Replace engine coolant	At 120,000 miles (192,000 km) or 10 years, then every 60,000 miles (96,000 km) or 5 years										
Replace brake fluid	Every 3 years (independent of mileage)										

# : See information on maintenance and emissions warranty, middle column, page 124 .

Service the items listed at the indicated distance (or time, if given).											
	miles x 1,000	15	30	45	60	75	90	105	120	135	150
	km x 1,000	24	48	72	96	120	144	168	192	216	240
Check engine oil and coolant	Check oil and coolant at each fuel stop										
Check tires	Check inflation and condition once a month or every 7,500 miles (12,000 km), whichever comes first										
Replace engine oil and oil filter	Every 3,750 miles (6,000 km) or every 6 months, whichever comes first										
Check front and rear brakes Inspect the following items: Tie-rod ends, steering gearbox, and boots Suspension components Driveshaft boots	Every 7,500 miles (12,000 km) or every 6 months, whichever comes first										
Check parking brake adjustment Lubricate all hinges, locks and latches Inspect the following items: Brake hoses and lines (including ABS) All fluid levels and condition of fluids Exhaust system <sup>#</sup> Fuel lines and connections <sup>#</sup> Lights and controls/vehicle underbody	Every 15,000 miles (24,000 km) or every 1 year, whichever comes first										
Inspect drive belts Replace dust and pollen filter <sup>*</sup>	Every 30,000 miles (48,000 km) or every 2 years, whichever comes first										
Replace air cleaner element	Every 15,000 miles (24,000 km) (Use normal schedule except in dusty conditions)										
Replace spark plugs							●				
Inspect valve clearance	Inspect every 105,000 miles (168,000 km), otherwise adjust only if noisy										
Replace manual transmission fluid	Every 60,000 miles (96,000 km) or every 3 years, whichever comes first										
Replace rear differential fluid	Every 15,000 miles (24,000 km) or every 1 year, whichever comes first										
Inspect idle speed							●				
Replace engine coolant	At 120,000 miles (192,000 km) or 10 years, then every 60,000 miles (96,000 km) or 5 years										
Replace brake fluid	Every 3 years (independent of mileage)										

# : See information on maintenance and emissions warranty, middle column, page 124.

\*: See dust and pollen filter on page 146 for replacement information under special driving conditions.



# Maintenance Record *(for Normal and Severe Schedules)*

You or the servicing dealer can record all completed maintenance here, whether you follow the schedule for normal conditions (page 125) or severe conditions (page 126). Keep the receipts for all work done on your vehicle.

<b>3,750 mi</b> 6,000 km	Signature or dealer stamp	mi/km
		Date
<b>7,500 mi</b> 12,000 km		mi/km
		Date
<b>11,250 mi</b> 18,000 km		mi/km
		Date
<b>15,000 mi</b> 24,000 km		mi/km
		Date
<b>18,750 mi</b> 30,000 km		mi/km
		Date
<b>22,500 mi</b> 36,000 km		mi/km
		Date
<b>26,250 mi</b> 42,000 km		mi/km
		Date
<b>30,000 mi</b> 48,000 km		mi/km
		Date

<b>33,750 mi</b> 54,000 km	Signature or dealer stamp	mi/km
		Date
<b>37,500 mi</b> 60,000 km		mi/km
		Date
<b>41,250 mi</b> 66,000 km		mi/km
		Date
<b>45,000 mi</b> 72,000 km		mi/km
		Date
<b>48,750 mi</b> 78,000 km		mi/km
		Date
<b>52,500 mi</b> 84,000 km		mi/km
		Date
<b>56,250 mi</b> 90,000 km		mi/km
		Date
<b>60,000 mi</b> 96,000 km		mi/km
		Date

CONTINUED

# Maintenance Record *(for Normal and Severe Schedules)*

---

<b>63,750 mi</b> 102,000 km	Signature or dealer stamp	mi/km
		Date
<b>67,500 mi</b> 108,000 km		mi/km
		Date
<b>71,250 mi</b> 114,000 km		mi/km
		Date
<b>75,000 mi</b> 120,000 km		mi/km
		Date
<b>78,750 mi</b> 126,000 km		mi/km
		Date
<b>82,500 mi</b> 132,000 km		mi/km
		Date
<b>86,250 mi</b> 138,000 km		mi/km
		Date
<b>90,000 mi</b> 144,000 km		mi/km
		Date

<b>93,750 mi</b> 150,000 km	Signature or dealer stamp	mi/km
		Date
<b>97,500 mi</b> 156,000 km		mi/km
		Date
<b>101,250 mi</b> 162,000 km		mi/km
		Date
<b>105,000 mi</b> 168,000 km		mi/km
		Date
<b>108,750 mi</b> 174,000 km		mi/km
		Date
<b>112,500 mi</b> 180,000 km		mi/km
		Date
<b>116,250 mi</b> 186,000 km		mi/km
		Date
<b>120,000 mi</b> 192,000 km		mi/km
		Date

## Maintenance Record *(for Normal and Severe Schedules)*

<b>123,750 mi</b> 198,000 km	Signature or dealer stamp	mi/km
		Date
<b>127,500 mi</b> 204,000 km		mi/km
		Date
<b>131,250 mi</b> 210,000 km		mi/km
		Date
<b>135,000 mi</b> 216,000 km		mi/km
		Date
<b>138,750 mi</b> 222,000 km		mi/km
		Date
<b>142,500 mi</b> 228,000 km		mi/km
		Date
<b>146,250 mi</b> 234,000 km		mi/km
		Date
<b>150,000 mi</b> 240,000 km		mi/km
		Date

# Fluid Locations

---

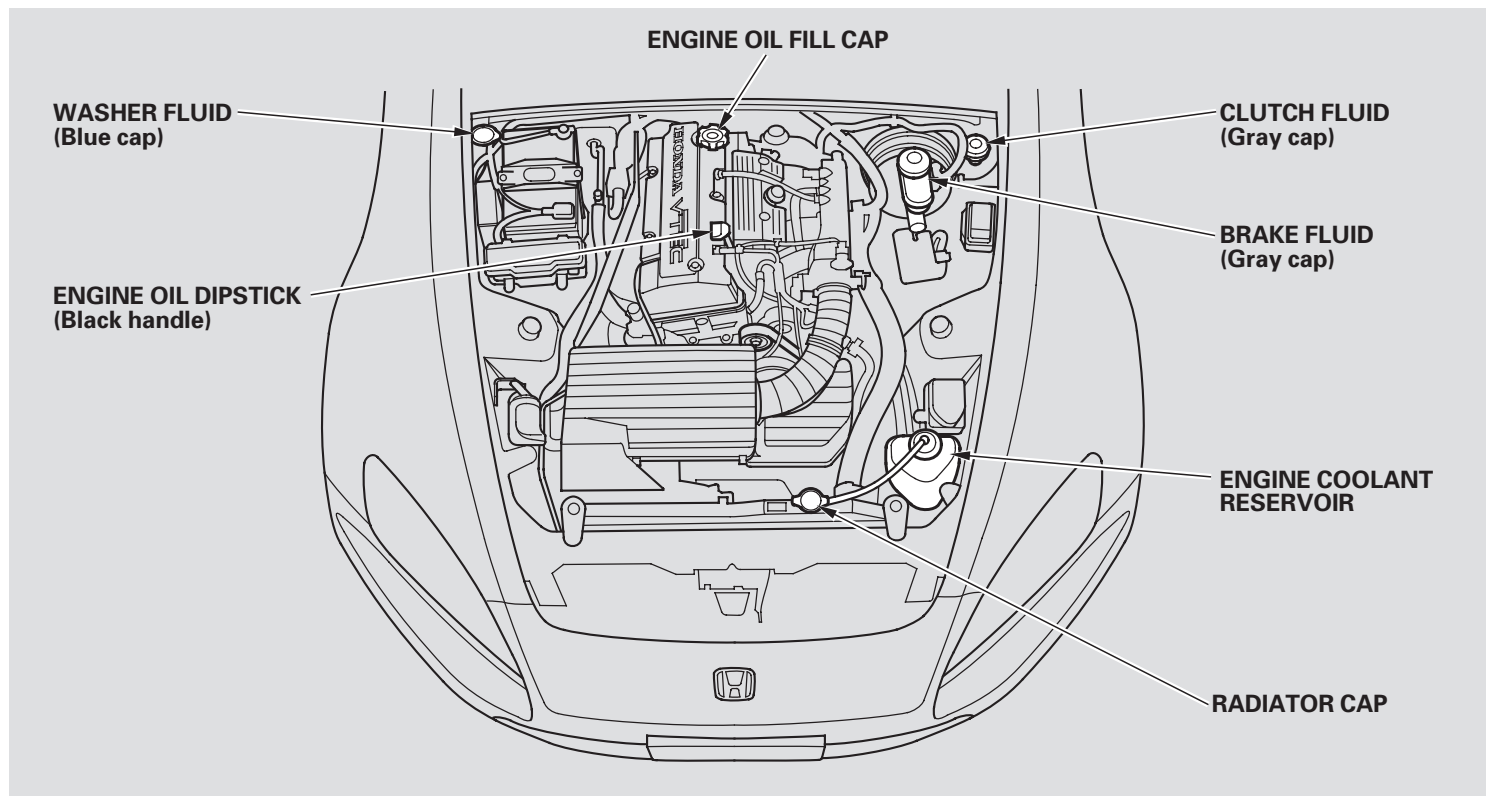

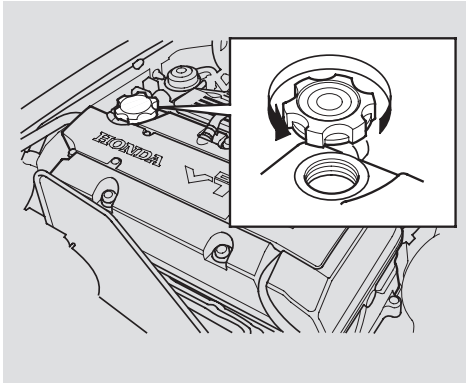

Unscrew and remove the engine oil fill cap on top of the valve cover. Pour in the oil slowly and carefully so you do not spill. Clean up any spills immediately. Spilled oil could damage components in the engine compartment.

Install the engine oil fill cap, and tighten it securely. Wait a few minutes, and recheck the oil level. Do not fill above the upper mark; you could damage the engine.

## Recommended Engine Oil

Oil is major contributor to your engine's performance and longevity. Always use a premium-grade detergent oil displaying the API Certification Seal. This seal indicates the oil is energy conserving, and that it meets the American Petroleum Institute's latest requirements. It is highly recommended that you use Honda motor oil in your vehicle for as long as you own it.

Make sure the API Certification Seal says "For Gasoline Engines".

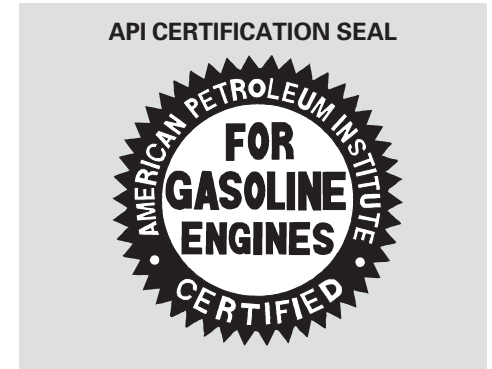

*CONTINUED*

# Adding Engine Oil, Changing the Oil and Filter

The oil's viscosity or weight is provided on the container's label. Select the oil for your vehicle according to this chart.

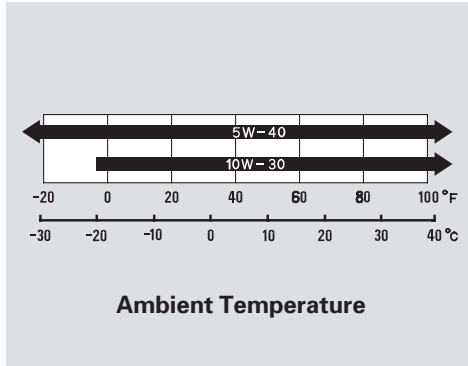

An oil with a viscosity of 10W-30 is preferred for optimum fuel economy and year-round protection in your vehicle. You may use a 5W-40 oil if the temperature in your area goes below 0°F (-20°C).

## Synthetic Oil

You may use a synthetic motor oil if it meets the same requirements given for a conventional motor oil: it displays the API Certification Seal, and it is the proper weight. You must follow the oil and filter change intervals given on the maintenance schedule.

## Engine Oil Additives

Your vehicle does not require any oil additives. Additives may adversely affect your engine's or transmission's performance and durability.

## Changing the Oil and Filter

Always change the oil and filter according to the recommendations in the maintenance schedule. The oil and filter collect contaminants that can damage your engine if they are not removed regularly.

Changing the oil and filter requires special tools and access from underneath the vehicle. The vehicle should be raised on a service station-type hydraulic lift for this service. Unless you have the knowledge and proper equipment, you should have this maintenance done by a skilled mechanic.

1. Run the engine until it reaches normal operating temperature, then shut it off.

## Changing the Oil and Filter

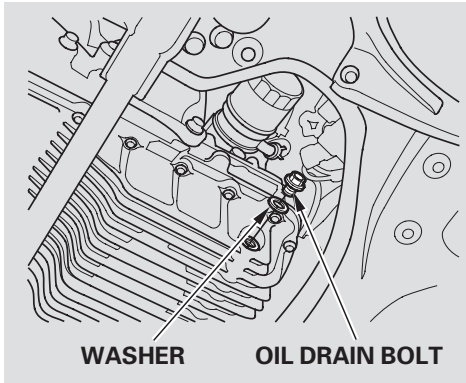

2. Open the hood, and remove the engine oil fill cap. Remove the oil drain bolt and washer from the bottom of the engine. Drain the oil into an appropriate container.

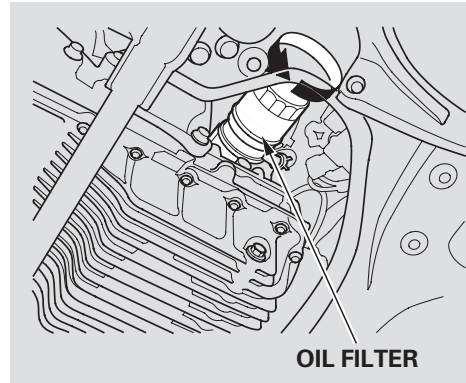

3. Remove the oil filter, and let the remaining oil drain. A special wrench (available from your dealer) is required.
4. Install a new oil filter according to the instructions that come with it. Make sure to clean off any dirt and dust on the connecting surface of a new oil filter.

5. Put a new washer on the drain bolt, then reinstall the drain bolt. Tighten the drain bolt to :  
33 lbf·ft (45 N·m , 4.6 kgf·m)

6. Refill the engine with the recommended oil.

Engine oil change capacity  
(including filter):  
5.1 US qt (4.8 l)

7. Install the engine oil fill cap. Start the engine. The oil pressure indicator should go out within 5 seconds. If it does not, turn off the engine, and check your work.
8. Let the engine run for several minutes, then check the drain bolt and oil filter for leaks.

*CONTINUED*

## Changing the Oil and Filter, Engine Coolant

---

- Turn off the engine and let it sit for several minutes, then check the oil level on the dipstick. If necessary, add more oil.

### NOTICE

*Improper disposal of engine oil can be harmful to the environment. If you change your own oil, please dispose of the used oil properly. Put it in a sealed container and take it to a recycling center. Do not discard it in a trash bin or dump it on the ground.*

### Adding Engine Coolant

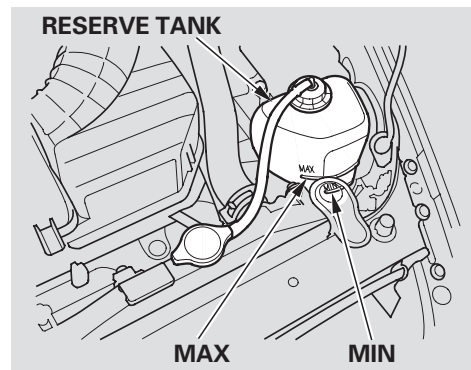

If the coolant level in the reserve tank is at or below the MIN line, add coolant to bring it up to the MAX line. Inspect the cooling system for leaks.

Always use Honda All Season Antifreeze/Coolant Type 2. This coolant is pre-mixed with 50 percent antifreeze and 50 percent water. Never add straight antifreeze or plain water.

If Honda antifreeze/coolant is not available, you may use another major-brand non-silicate coolant as a temporary replacement. Make sure it is a high-quality coolant recommended for aluminum engines. Continued use of any non-Honda coolant can result in corrosion, causing the cooling system to malfunction or fail. Have the cooling system flushed and refilled with Honda antifreeze/coolant as soon as possible.



If the reserve tank is completely empty, you should also check the coolant level in the radiator.

## **⚠ WARNING**

Removing the radiator cap while the engine is hot can cause the coolant to spray out, seriously scalding you.

Always let the engine and radiator cool down before removing the radiator cap.

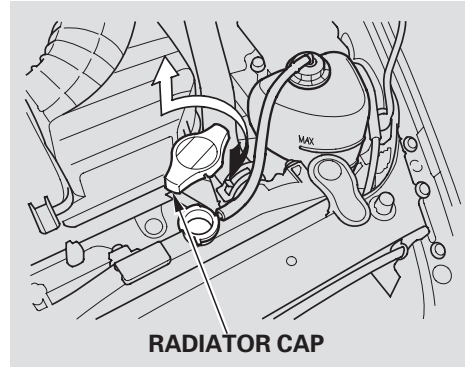

1. When the radiator and engine are cool, relieve any pressure in the cooling system by turning the radiator cap counterclockwise, without pressing down.
2. Remove the radiator cap by pushing down and turning counterclockwise.

3. The coolant level should be up to the base of the filler neck. Add coolant if it is low.

Pour the coolant slowly and carefully so you do not spill. Clean up any spill immediately; it could damage components in the engine compartment.

4. Put the radiator cap on, and tighten it fully.
5. Pour coolant into the reserve tank. Fill it to halfway between the MAX and MIN marks. Put the cap back on the reserve tank.

Do not add any rust inhibitors or other additives to your vehicle's cooling system. They may not be compatible with the coolant or engine components.

## Windshield Washers

Check the fluid level in the windshield washer reservoir at least monthly during normal use.

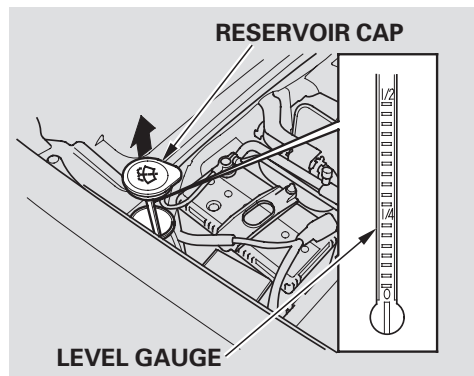

Check the fluid level by looking at the level gauge attached to the cap.

Fill the reservoir with a good-quality windshield washer fluid. This increases the cleaning capability and prevents freezing in cold weather.

When you refill the reservoir, clean the edges of the windshield wiper blades with windshield washer fluid on a clean cloth. This will help to condition them.

### NOTICE

*Do not use engine antifreeze or a vinegar/water solution in the windshield washer reservoir. Antifreeze can damage your vehicle's paint, while a vinegar/water solution can damage the windshield washer pump. Use only commercially-available windshield washer fluid.*

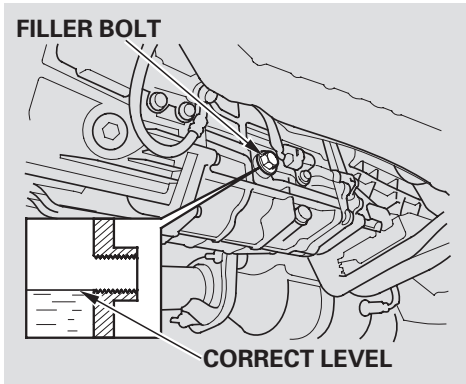

Check the fluid level with the transmission at normal operating temperature and the vehicle sitting on level ground. Remove the transmission filler bolt, and carefully feel inside the bolt hole with your finger. The fluid level should be up to the edge of the bolt hole. If it is not, add Honda Manual Transmission Fluid (MTF) until it starts to run out of the hole. Install the filler bolt, and tighten it securely.

If Honda MTF is not available, you may use an SAE 10W-30 or 10W-40 viscosity motor oil with the API Certification seal that says “FOR GASOLINE ENGINES” as a temporary replacement. However, motor oil does not contain the proper additives, and continued use can cause stiffer shifting. Replace as soon as it is convenient.

The transmission should be drained and refilled with new fluid according to the time and distance recommendations in the maintenance schedule.

If you are not sure how to check and add fluid, contact your dealer.

## Differential Fluid

---

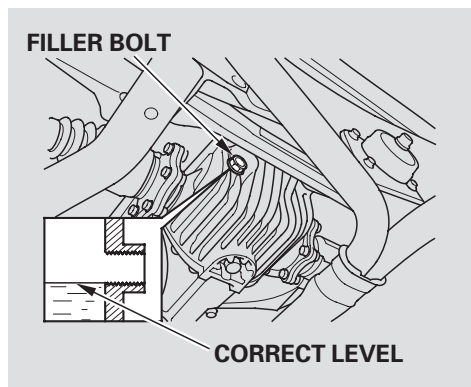

Check the fluid level with the differential at normal operating temperature and the vehicle sitting on level ground. Remove the differential fluid filler bolt and washer, and carefully feel inside the bolt hole with your finger. The fluid level should be up to the edge of the bolt hole. If it is not, slowly add fluid until it starts to run out of the hole.

Use an SAE 90 viscosity hypoid gear oil, API service classified GL5 or GL6 only.

Put a new washer on the filler bolt, then reinstall the filler bolt. Tighten it securely. Tightening torque:  
**33 lbf·ft (45 N·m , 4.6 kgf·m)**

The differential should be drained and refilled with new fluid according to the time and distance recommendations in the maintenance schedule.

If you are not sure how to check and add fluid, contact your dealer.

Check the brake fluid level in the reservoirs monthly.

Replace the brake fluid according to the time recommendation in the maintenance schedule.

Always use Honda Heavy Duty Brake Fluid DOT 3. If it is not available, you should use only DOT 3 or DOT 4 fluid, from a sealed container, as a temporary replacement.

Using any non-Honda brake fluid can cause corrosion and decrease the life of the system. Have the brake system flushed and refilled with Honda Heavy Duty Brake Fluid DOT 3 as soon as possible.

Brake fluid marked DOT 5 is not compatible with your vehicle's braking system and can cause extensive damage.

## Brake System

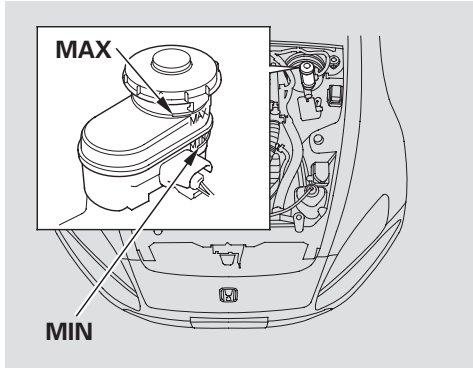

The fluid level should be between the MIN and MAX marks on the side of the reservoir. If the level is at or below the MIN mark, your brake system needs attention. Have the brake system inspected for leaks or worn brake pads.

## Clutch System

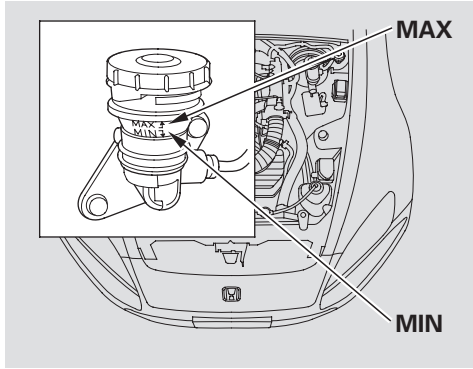

The fluid level should be between the MIN and MAX marks on the side of the reservoir. If it is not, add brake fluid to bring it up to that level. Use the same fluid specified for the brake system.

A low fluid level can indicate a leak in the clutch system. Have this system inspected as soon as possible.

# Lights

---

## Headlight Aiming

The headlights were properly aimed when your vehicle was new. If you regularly carry heavy items in the trunk, readjustment may be required. Adjustment should be done by your dealer or other qualified mechanic.

## Replacing a Headlight Bulb

The low beam headlight bulbs are a type of high voltage discharge tube. High voltage can remain in the circuit even with the light switch off and the key removed. Because of this, you should not attempt to examine or change a low beam headlight bulb yourself. If a low beam headlight bulb fails, take the vehicle to your dealer to have it replaced.

Halogen bulbs are used for the high beam headlight bulbs. When replacing a high beam headlight bulb, handle it by its base, and protect the glass from contact with your skin or hard objects. If you touch the glass, clean it with denatured alcohol and a clean cloth.

### **NOTICE**

*Halogen headlight bulbs get very hot when lit. Oil, perspiration, or a scratch on the glass can cause the bulb to overheat and shatter.*

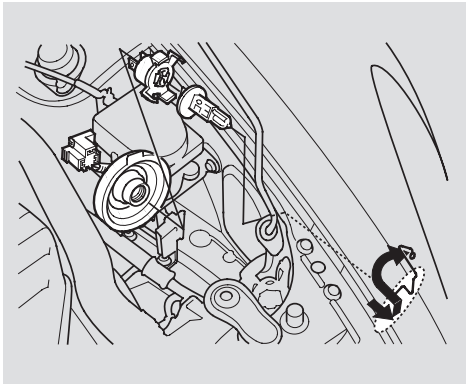

1. Open the hood.  
If you need to change the high beam headlight bulb on the left side, remove the coolant reserve tank from its holder by pulling it straight up.
2. Remove the electrical connector from the bulb by squeezing the connector to unlock the tab, then slide the connector off the bulb.

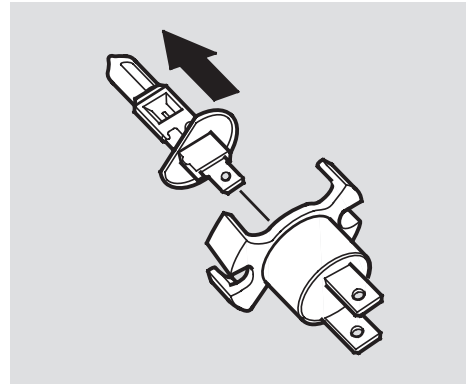

3. Remove the rubber weather seal by pulling on the tab.
4. Unclip the end of the hold-down wire from its slot. Pivot it out of the way, and remove the bulb socket.
5. Pull the bulb straight out of its socket. Push the new bulb straight into the socket until it bottoms.

6. Insert the socket back into the headlight assembly. Make sure the bulb is installed correctly by looking through the headlight lens. The pins on the base of the bulb should fit in the holes in the headlight assembly. Pivot the hold-down wire back in place, and clip the end into the slot.
7. Install the rubber seal over the back of the headlight assembly.
8. Push the electrical connector onto the new bulb. Turn on the headlights to test the new bulb.
9. (Left side)  
Reinstall the coolant reserve tank.

# Lights

## Replacing Front Turn Signal and Side Marker/Parking Light Bulbs

1. If you are changing the bulb on the driver's side, start the engine, turn the steering wheel all the way to the right, then turn off the engine. If you are changing the bulb on the passenger's side, turn the steering wheel to the left.

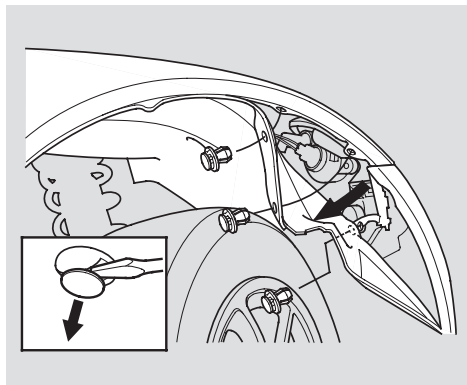

2. Use a flat-tipped screwdriver to remove the three holding clips from the inner fender.
3. Pull the inner fender cover back.
4. Remove the socket from the headlight assembly by turning it one-quarter turn counterclockwise.
5. Pull the bulb straight out of its socket.

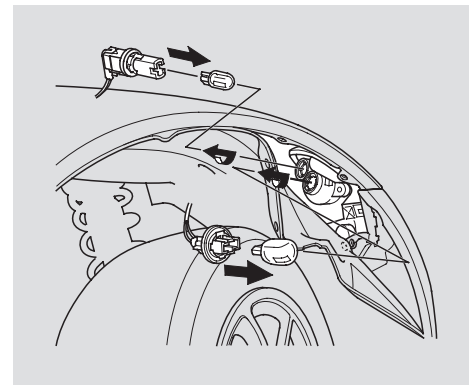

6. Install the new bulb in the socket.
7. Insert the socket back into the headlight assembly. Turn it clockwise to lock it in place.
8. Turn on the lights to make sure the new bulb is working.
9. Put the inner fender cover in place. Install the three holding clips. Lock each clip in place by pushing on the center.



## Replacing a Side Turn Signal Bulb

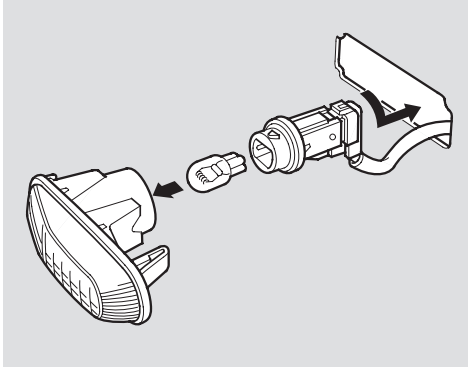

1. Use a small flat-tipped screwdriver to pry carefully on the back edge of the side turn signal assembly until it pops out of the body.
2. Turn the bulb holder one-quarter turn counterclockwise to remove it from the lens.
3. Pull the bulb straight out of its socket. Push the new bulb straight into the socket until it bottoms.
4. Put the bulb holder back into its hole in the lens, and turn it clockwise until it locks.
5. Turn on the lights to make sure the new bulb is working.
6. Put the side turn signal assembly back into the body, front first. Push on the back edge until it snaps into place.

# Lights

## Replacing Rear Bulbs

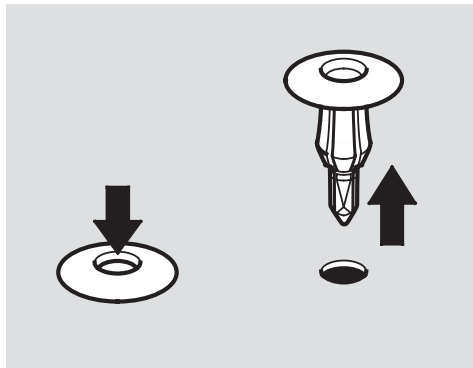

1. Open the trunk.
2. Remove the fasteners from the trunk lining. To remove a fastener, push on the center of the head until it pops in, then pull the fastener out.
3. Pull the lining back.

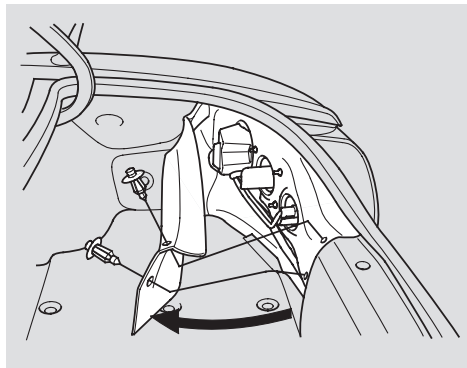

4. Determine which bulb is burned out: turn signal or back-up light.

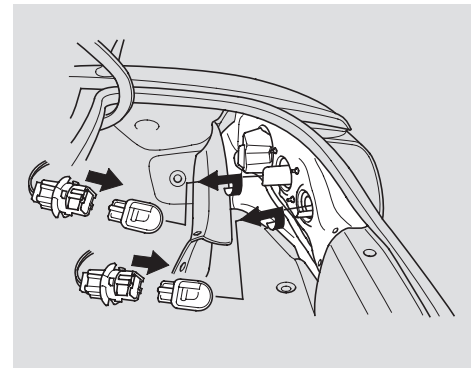

5. Remove the socket by turning it one-quarter turn counterclockwise.
6. Remove the burned out bulb by pulling it straight out of its socket.

7. Install the new bulb into the socket.
8. Push the socket into the light assembly, and turn it clockwise until it locks.
9. Turn on the lights to make sure the new bulb is working.

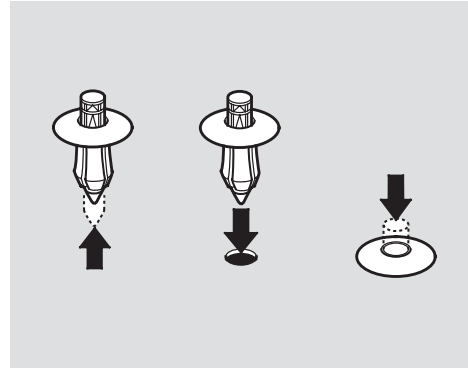

10. Install the trunk lining, and secure it with the fasteners. To reinstall a fastener, reset the fastener by pushing on the pointed end until it pops back almost flush with the fingers on the housing. Put the fastener in the hole of the trunk lining, and push on the center until it locks (the center is flush with the head).

### Cleaning the Seat Belts

If your seat belts get dirty, use a soft brush with a mixture of mild soap and warm water to clean them. Do not use bleach, dye, or cleaning solvents. Let the belts air-dry before you use the vehicle.

Dirt build-up in the loops of the seat belt anchors can cause the belts to retract slowly. Wipe the insides of the loops with a clean cloth dampened in mild soap and warm water or isopropyl alcohol.

## Floor Mats, Dust and Pollen Filter

---

### Floor Mats

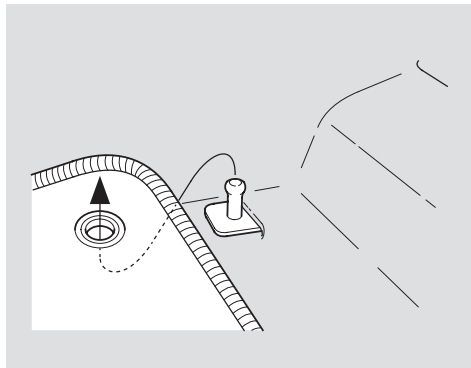

The driver's floor mat that came with your vehicle hooks over the floor mat anchor. This keeps the floor mat from sliding forward and possibly interfering with the pedals.

If you remove the driver's floor mat, make sure to re-anchor it when you put it back in your vehicle.

If you use a non-Honda floor mat, make sure it fits properly and that it can be used with the floor mat anchor. Do not put additional floor mats on top of the anchored mat.

### Dust and Pollen Filter

This filter removes the dust and pollen that is brought in from the outside through the heating and cooling system.

Have your dealer replace this filter every 30,000 miles (48,000 km) under normal conditions. It should be replaced every 15,000 miles (24,000 km) if you drive primarily in urban areas that have high concentrations of soot in the air, or if the flow from the heating and cooling system becomes less than usual.

Check the condition of the wiper blades at least every six months. Replace them if you find signs of cracking in the rubber, areas that are getting hard, or if they leave streaks and unwiped areas when used.

To replace a wiper blade:  
1. Raise the wiper arm off the windshield.

**NOTICE**

*Do not open the hood when the wiper arms are raised, or you will damage the hood and the wiper arms.*

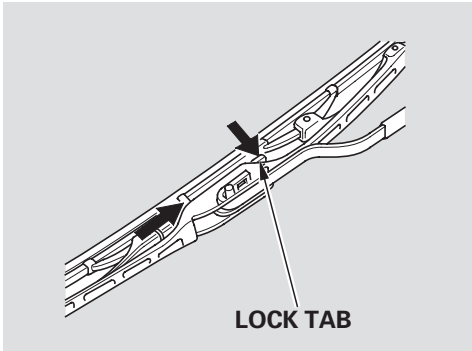

2. Disconnect the blade assembly from the wiper arm by pushing in the lock tab. Hold the lock tab in while you push the blade assembly toward the base of the arm.

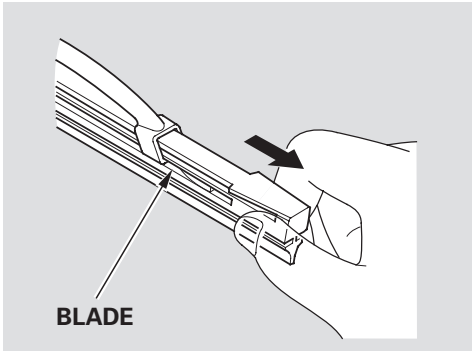

3. Remove the blade from its holder by grasping the tabbed end of the blade. Pull firmly until the tabs come out of the holder.

CONTINUED

# Wiper Blades, Tires

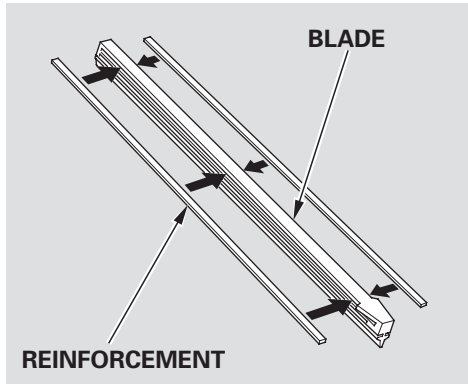

4. Examine the new wiper blades. If they have no plastic or metal reinforcement along the back edge, remove the metal reinforcement strips from the old wiper blade, and install them in the slots along the edge of the new blade.

5. Slide the new wiper blade into the holder until the tabs lock.
6. Slide the wiper blade assembly onto the wiper arm. Make sure it locks in place.
7. Lower the wiper arm down against the windshield.

## Tires

To safely operate your vehicle, your tires must be the proper type and size, in good condition with adequate tread, and correctly inflated.

The following pages give more detailed information on how to take care of your tires and what to do when they need to be replaced.

### **⚠ WARNING**

Using tires that are excessively worn or improperly inflated can cause a crash in which you can be seriously hurt or killed.

Follow all instructions in this owner's manual regarding tire inflation and maintenance.

## Inflation Guidelines

Keeping the tires properly inflated provides the best combination of handling, tread life, and riding comfort.

- Underinflated tires wear unevenly, adversely affect handling and fuel economy, and are more likely to fail from being overheated.
- Overinflated tires can make your vehicle ride more harshly, are more prone to damage from road hazards, and wear unevenly.

We recommend that you visually check your tires every day. If you think a tire might be low, check it immediately with a tire gauge.

Use a gauge to measure the air pressure in each tire at least once a month. Even tires that are in good condition may lose one to two psi (10 to 20 kPa, 0.1 to 0.2 kgf/cm<sup>2</sup>) per month. Remember to check the spare tire at the same time.

Check the air pressures when the tires are cold. This means the vehicle has been parked for at least three hours, or driven less than 1 mile (1.6 km). Add or release air, if needed, to match the recommended cold tire pressures on page [150](#).

If you check air pressures when the tires are hot [driven for several miles (kilometers)], you will see readings 4 to 6 psi (30 to 40 kPa, 0.3 to 0.4 kgf/cm<sup>2</sup>) higher than the cold readings. This is normal. Do not let air out to match the recommended cold air pressure. The tire will be underinflated.

You should use your own tire pressure gauge whenever you check your tire pressures. This will make it easier for you to tell if a pressure loss is due to a tire problem and not due to a variation between gauges.

While tubeless tires have some ability to self-seal if they are punctured, you should look closely for punctures if a tire starts losing pressure.

# Tires

## Recommended Tire Pressures

The following chart shows the recommended cold tire pressures for most normal and high-speed driving conditions.

### Front:

Tire Size	Cold Tire Pressure
215/45R17 87W	32 psi (220 kPa , 2.2 kgf/cm <sup>2</sup> )

### Rear:

Tire Size	Cold Tire Pressure
245/40R17 91W	32 psi (220 kPa , 2.2 kgf/cm <sup>2</sup> )

The compact spare tire pressure is:  
60 psi (420 kPa , 4.2 kgf/cm<sup>2</sup>)

For convenience, the recommended cold air pressures and tire sizes are on a label on the driver's doorjamb.

For additional information about your tires, see page [186](#).

## Tire Inspection

Every time you check inflation, you should also examine the tires for damage, foreign objects, and wear. You should look for:

- Bumps or bulges in the tread or side of the tire. Replace the tire if you find either of these conditions.
- Cuts, splits, or cracks in the side of the tire. Replace the tire if you can see fabric or cord.
- Excessive tread wear.

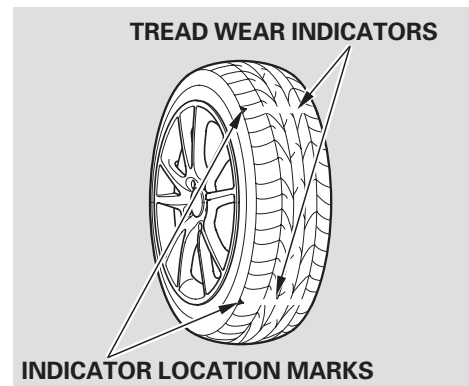

Your tires have wear indicators molded into the tread. When the tread wears down, you will see a 1/2 inch (12.7 mm) wide band across the tread. This shows there is less than 1/16 inch (1.6 mm) of tread left on the tire.

A tire this worn gives very little traction on wet roads. You should replace the tire if you can see three or more tread wear indicators.



## Tire Maintenance

In addition to proper inflation, correct wheel alignment helps to decrease tire wear. If you find a tire is worn unevenly, have your dealer check the wheel alignment.

Have your dealer check the tires if you feel a consistent vibration while driving. A tire should always be rebalanced if it is removed from the wheel. When you have new tires installed, make sure they are balanced. This increases riding comfort and tire life. For best results, have the installer perform a dynamic balance.

### NOTICE

*Improper wheel weights can damage your vehicle's aluminum wheels. Use only Honda wheel weights for balancing.*

## Tire Rotation

You should not rotate your vehicle's tires. The front and rear tires are different sizes, so they cannot be rotated front-to-rear. The original-equipment tires on your vehicle have a unidirectional tread pattern, so they cannot be rotated side-to-side.

## Tire Wear

The tires that came on your vehicle were designed and constructed to provide superior grip during acceleration, braking, and cornering.

As a trade-off, they will wear more rapidly than tires used on ordinary passenger vehicles. Because of the vehicle's weight distribution, and the fact that the rear wheels are the driving wheels, you can expect them to wear more rapidly than the front tires.

The mileage you can expect from your vehicle tires is the same as comparable mid-and rear-engine sports cars, and it will vary greatly with your driving habits.

If you drive moderately, the rear tires could last more than 10,000 miles (16,000 km). However, the mileage will be substantially less if you tend to drive your vehicle at the upper limits of its capabilities.

You should carefully inspect your vehicle's tires for wear, damage, and proper inflation every 7,500 miles (12,000 km) (see page 125 ).

# Tires

---

## Replacing Tires and Wheels

Replace your tires with radial tires of the same size, load range, speed rating, and maximum cold tire pressure rating (as shown on the tire's sidewall).

Mixing radial and bias-ply tires on your vehicle can reduce braking ability, traction, and steering accuracy. Using tires of a different size or construction can cause the ABS to work inconsistently.

It is best to replace all four tires at the same time. If that is not possible or necessary, replace the two front tires or two rear tires as a pair. Replacing just one tire can seriously affect your vehicle's handling.

The ABS works by comparing the speed of the wheels. When replacing tires, use the same size originally supplied with the vehicle. Tire size and construction can affect wheel speed and may cause the system to work.

If you ever replace a wheel, make sure that the wheel's specifications match those of the original wheels. Replacement wheels are available at your dealer.

### **WARNING**

Installing improper tires on your vehicle can affect handling and stability. This can cause a crash in which you can be seriously hurt or killed.

Always use the size and type of tires recommended in this owner's manual.

## Wheel and Tire Specifications

Wheels:

Front:

17 x 7 JJ

Rear:

17 x 8 1/2 JJ

Tires:

Front:

215/45R17 87W

Rear:

245/40R17 91W

See page [186](#) for information about DOT Tire Quality Grading, and page [188](#) for tire size and labeling information.

## Winter Driving

Tires marked “M + S” or “All Season” on the sidewall have an all-weather tread design suitable for most winter driving conditions.

For the best performance in snowy or icy conditions, you should install snow tires or tire chains. They may be required by local laws under certain conditions.

## Snow Tires

If you mount snow tires on your vehicle, make sure they are radial tires of the same size and load range as original tires. Mount snow tires on all four wheels. The traction provided by snow tires on dry roads may be lower than your original tires. Check with the tire dealer for maximum speed recommendations.

## Tire Chains

Because your vehicle has limited tire clearance, mount only SAE Class “S” cable-type traction devices, with rubber chain tensioners on the rear tires. Use traction devices only when required by driving conditions or local laws. Make sure they are the correct size for your tires. Metal link-type “chains” should not be used.

When installing cables, follow the manufacturer’s instructions, and mount them as tight as you can. Make sure they are not contacting the brake lines or suspension. Drive slowly with them installed. If you hear them coming into contact with the body or chassis, stop and investigate. Remove them as soon as you begin driving on cleared roads.

## NOTICE

*Traction devices that are the wrong size or improperly installed can damage your vehicle’s brake lines, suspension, body, and wheels. Stop driving if they are hitting any part of the vehicle.*

## Checking the Battery

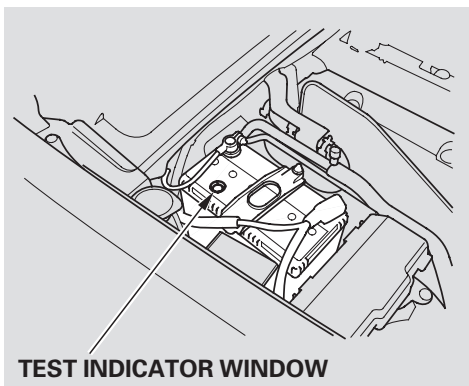

Check the condition of the battery monthly by looking at the test indicator window. The label on the battery explains the test indicator's colors.

Check the terminals for corrosion (a white or yellowish powder). To remove it, cover the terminals with a solution of baking soda and water. It will bubble up and turn brown. When this stops, wash it off with plain water. Dry off the battery with a cloth or paper towel. Coat the terminals with grease to help prevent future corrosion.

If additional battery maintenance is needed, see your dealer or a qualified technician.

**WARNING:** Battery posts, terminals, and related accessories contain lead and lead compounds. **Wash your hands after handling.**

If you need to connect the battery to a charger, disconnect both cables to prevent damaging your vehicle's electrical system. Always disconnect the negative (–) cable first, and reconnect it last.

### **⚠ WARNING**

The battery gives off explosive hydrogen gas during normal operation.

A spark or flame can cause the battery to explode with enough force to kill or seriously hurt you.

Wear protective clothing and a face shield, or have a skilled mechanic do the battery maintenance.

If you need to park your vehicle for an extended period (more than one month), there are several things you should do to prepare it for storage. Proper preparation helps prevent deterioration and makes it easier to get your vehicle back on the road. If possible, store your vehicle indoors.

- Fill the fuel tank.
- Change the engine oil and filter.
- Wash and dry the exterior completely.
- Clean the interior. Make sure the carpeting, floor mats, etc., are completely dry.
- Raise the convertible top cover.
- Leave the parking brake off. Put the transmission in Reverse.

- Block the rear wheels.
- If the vehicle is to be stored for a longer period, it should be supported on jackstands so the tires are off the ground.
- Leave one window open slightly (if the vehicle is being stored indoors).
- Disconnect the battery.
- Support the front wiper blade arms with a folded towel or rag so they do not touch the windshield.
- To minimize sticking, apply a silicone spray lubricant to all door and trunk seals. Also, apply a vehicle body wax to the painted surfaces that mate with the door and trunk seals.

- Cover the vehicle with a “breathable” cover, one made from a porous material such as cotton. Non-porous materials, such as plastic sheeting, trap moisture, which can damage the paint.
- If possible, periodically run the engine until it reaches full operating temperature (the cooling fan cycles on and off twice). Preferably, do this once a month.

If you store your vehicle for 1 year or longer, have your dealer perform the inspections called for in the 2 years/30,000 miles (48,000 km) maintenance schedule (Normal Conditions) as soon as you take it out of storage (see page 125 ). The replacements called for in the maintenance schedule are not needed unless the vehicle has actually reached that time or mileage.



This section covers the more common problems that motorists experience with their vehicles. It gives you information about how to safely evaluate the problem and what to do to correct it. If the problem has stranded you on the side of the road, you may be able to get going again. If not, you will also find instructions on getting your vehicle towed.

Compact Spare Tire.....	158
Changing a Flat Tire .....	159
If the Engine Won't Start.....	164
Jump Starting .....	166
If the Engine Overheats .....	167
Low Oil Pressure Indicator .....	170
Charging System Indicator.....	170
Malfunction Indicator Lamp .....	171
Brake System Indicator .....	172
Closing the Convertible Top .....	173
Fuses .....	174
Checking and Replacing .....	175
Fuse Locations.....	177
Emergency Towing .....	179
If Your Vehicle Gets Stuck.....	179

## Compact Spare Tire

Use the compact spare tire as a temporary replacement only. Get your regular tire repaired or replaced, and put it back on your vehicle as soon as you can.

Check the inflation pressure of the compact spare tire every time you check the other tires. It should be inflated to:  
60 psi (420 kPa , 4.2 kgf/cm<sup>2</sup>)

Follow these precautions:

- Never exceed 50 mph (80 km/h).
- This tire gives a harsher ride and less traction on some road surfaces. Use greater caution while driving.
- Do not mount snow chains on it.
- Do not use your compact spare tire on another vehicle unless it is the same make and model.
- Do not use a compact spare tire mounted on a rear wheel; it will damage the limited slip differential (see page [159](#) ).

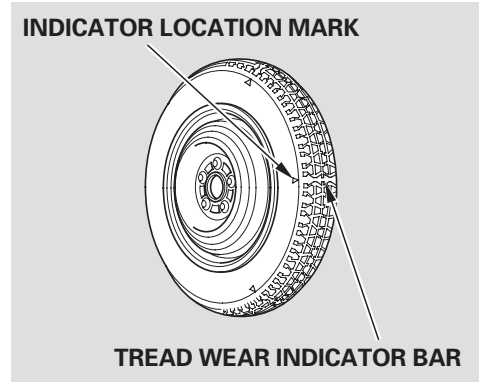

Replace the tire when you can see the tread wear indicator bars. The replacement should be the same size and design tire, mounted on the same wheel. The spare tire is not designed to be mounted on a regular wheel, and the spare wheel is not designed for mounting a regular tire.



If you have a flat tire while driving, stop in a safe place to change it. Drive slowly along the shoulder until you get to an exit or an area that is far away from the traffic lanes.

## **⚠️ WARNING**

The vehicle can easily roll off the jack, seriously injuring anyone underneath.

Follow the directions for changing a tire exactly, and never get under the vehicle when it is supported only by the jack.

The compact spare tire is smaller than a standard tire, which will affect the vehicle's handling. Drive cautiously when this spare is mounted on your vehicle.

The size difference may also cause damage to the rear differential, so do not mount the compact spare on the rear. If either rear tire goes flat, remove the front tire on that same side, mount the compact spare tire on the front, then mount the front tire on the rear.

1. Park the vehicle on firm, level, and non-slippery ground. Put the transmission in Reverse. Apply the parking brake.
2. Turn on the hazard warning lights, and turn the ignition switch to LOCK (0). Have your passenger get out of the vehicle while you change the tire.

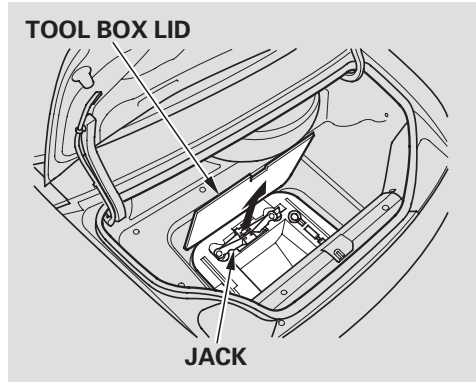

3. Open the trunk. Lift up the tool box lid, and take the jack, wheel wrench, and extension out of the tool box.

## **NOTICE**

*Use the jack that came with your vehicle. If you try to raise another vehicle with this jack or use another jack to raise your vehicle, the vehicle or jack can be damaged.*

CONTINUED

# Changing a Flat Tire

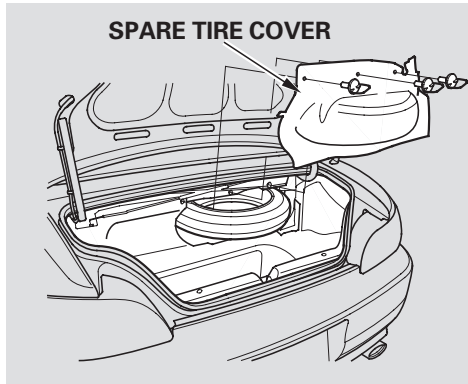

4. Remove the three clips holding the spare tire cover by pulling the rings straight back. Remove the spare tire cover.

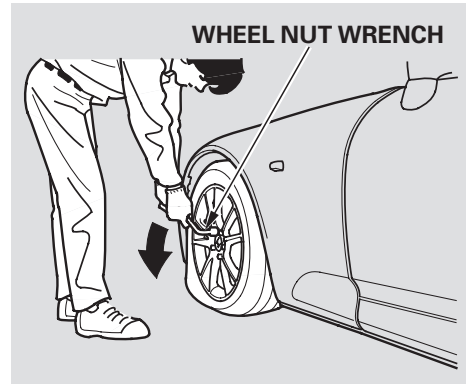

5. Unscrew the wing bolt, and take the spare tire out of the spare tire shelf.
6. Loosen each wheel nut 1/2 turn with the wheel nut wrench.

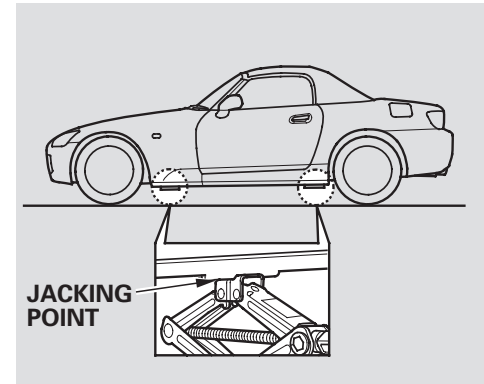

7. Place the jack under the jacking point nearest the tire you need to change. Turn the end bracket clockwise until the top of the jack contacts the jacking point. Make sure the center of the jacking point tab is resting in the jack notch.

## Changing a Flat Tire

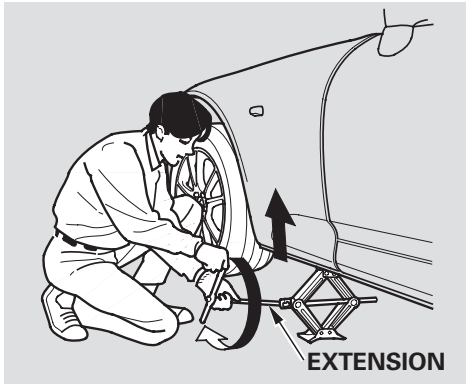

8. Use the extension and the wheel nut wrench as shown to raise the vehicle until the flat tire is off the ground.



9. Remove the wheel nuts, then remove the flat tire. Handle the wheel nuts carefully; they may be hot from driving. Place the flat tire on the ground with the outside surface facing up.

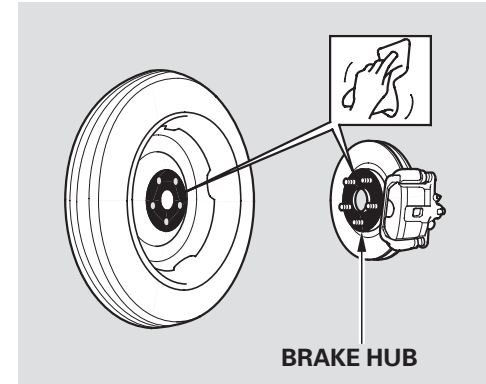

10. Before mounting the spare tire, wipe any dirt off the mounting surface of the wheel and hub with a clean cloth. Wipe the hub carefully; it may be hot from driving.

CONTINUED

## Changing a Flat Tire

---

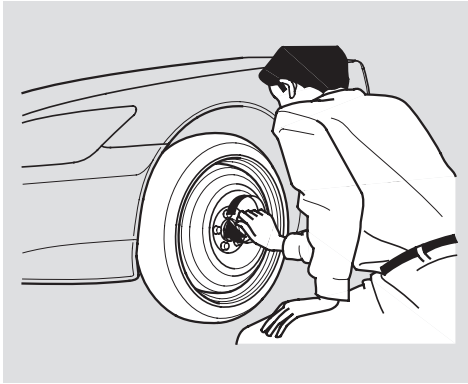

11. Put on the spare tire. Put the wheel nuts back on finger-tight, then tighten them in a crisscross pattern with the wheel nut wrench until the wheel is firmly against the hub. Do not try to tighten them fully.

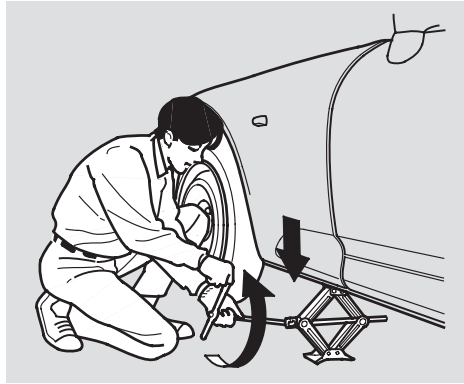

12. Lower the vehicle to the ground, and remove the jack.

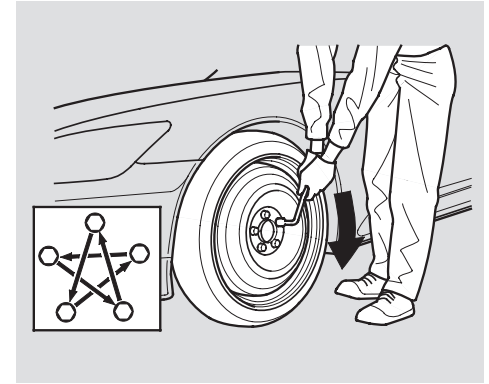

13. Tighten the wheel nuts securely in a crisscross pattern. Have the wheel nut torque checked at the nearest automotive service facility. Tighten the wheel nuts to:  
80 lbf·ft (108 N·m , 11 kgf·m)

14. Remove the tool box from the trunk well, and replace the jack, wheel wrench, and extension in the tool box.
15. Place the tool box into the spare tire shelf in the trunk.

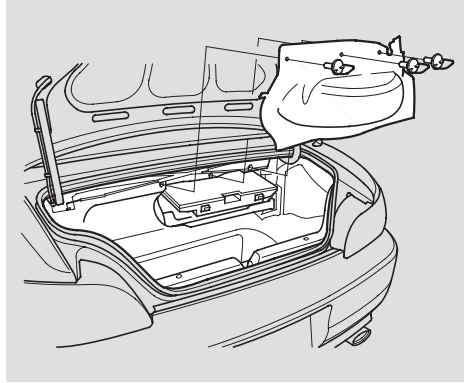

16. Replace the spare tire cover. Secure it with the three clips. Push each clip in securely, and pivot the ring down flat.

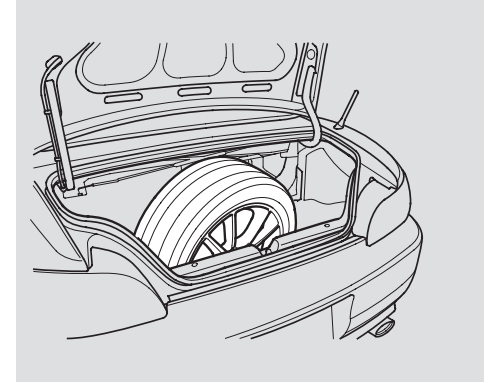

17. Put the flat tire in the trunk well vertically as shown.

## If the Engine Won't Start

---

Diagnosing why the engine won't start falls into two areas, depending on what you hear when you press the ENGINE START button.

- You hear nothing, or almost nothing. The engine's starter motor does not operate at all, or operates very slowly.
- You can hear the starter motor operating normally, or the starter motor sounds like it is spinning faster than normal, but the engine does not start up and run.

### **Nothing Happens or the Starter Motor Operates Very Slowly**

When you press the ENGINE START button, you do not hear the normal noise of the engine trying to start. You may hear a clicking sound or series of clicks, or nothing at all. Check these things:

- Check the transmission interlock. The clutch pedal must be pushed all the way to the floor or the starter will not operate.
- Turn the ignition switch to ON (II). Turn on the headlights, and check their brightness. If the headlights are very dim or do not come on at all, the battery is discharged. See **Jump Starting** on page [166](#) .

- Press the ENGINE START button, then release it. If the headlights do not dim, check the condition of the fuses. If the fuses are OK, there is probably something wrong with the electrical circuit for the ignition switch or starter motor. You will need a qualified technician to determine the problem. (See **Emergency Towing** on page [179](#) .)

If the headlights dim noticeably or go out when you try to start the engine, either the battery is discharged or the connections are corroded. Check the condition of the battery and terminal connections (see page [154](#)). You can then try jump starting the vehicle from a booster battery (see page [166](#)).

### **The Starter Operates Normally**

In this case, the starter motor's speed sounds normal, or even faster than normal, when you press the ENGINE START button, but the engine does not run.

- Are you using a properly coded key? An improperly coded key will cause the immobilizer system indicator in the instrument panel to blink rapidly (see page [52](#)).
- Are you using the proper starting procedure? Refer to **Starting the Engine** on page [114](#).
- Do you have fuel? Check the fuel gauge; the low fuel indicator may not be working.

- There may be an electrical problem, such as no power to the fuel pump. Check all the fuses (see page [174](#)).

If you find nothing wrong, you will need a qualified technician to find the problem. See **Emergency Towing** on page [179](#).

# Jump Starting

Although this seems like a simple procedure, you should take several precautions.

## **⚠ WARNING**

A battery can explode if you do not follow the correct procedure, seriously injuring anyone nearby.

Keep all sparks, open flames, and smoking materials away from the battery.

To jump start your vehicle:

1. Open the hood, and check the physical condition of the battery. In very cold weather, check the condition of the electrolyte. If it seems slushy or frozen, do not try jump starting until it thaws.

## **NOTICE**

*If a battery sits in extreme cold, the electrolyte inside can freeze. Attempting to jump start with a frozen battery can cause it to rupture.*

2. Turn off all the electrical accessories: heater, A/C, audio system, lights, etc. Put the transmission in Neutral, and set the parking brake.

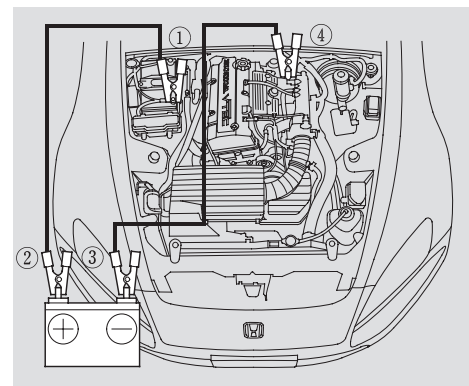

The numbers in the illustration show you the order to connect the jumper cables.

3. Connect one jumper cable to the positive (+) terminal on your battery. Connect the other end to the positive (+) terminal on the booster battery.



## Jump Starting, If the Engine Overheats

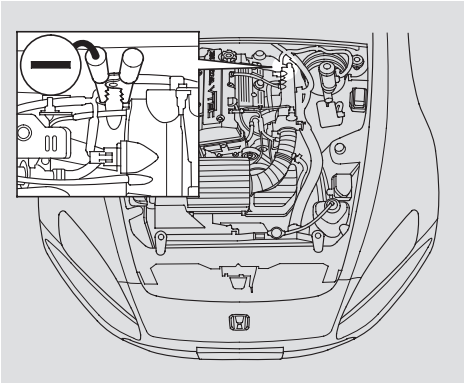

4. Connect the second jumper cable to the negative (–) terminal on the booster battery. Connect the other end to the grounding strap as shown. Do not connect this jumper cable to any other part of the engine.
5. If the booster battery is in another vehicle, have an assistant start that vehicle and run it at a fast idle.
6. Start your vehicle. If the starter motor still operates slowly, check that the jumper cables have good metal-to-metal contact.
7. Once your vehicle is running, disconnect the negative cable from your vehicle, then from the booster battery. Disconnect the positive cable from your vehicle, then from the booster battery.

Keep the ends of the jumper cables away from each other and any metal on the vehicle until everything is disconnected. Otherwise, you may cause an electrical short.

### If the Engine Overheats

The reading on your vehicle's temperature gauge should stay in the midrange under most conditions. If it reaches the red mark, you should determine the reason (hot day, driving up a steep hill, etc.).

If your vehicle overheats, you should take immediate action. The only indication may be the temperature gauge reading reaching the red mark. Or you may see steam or spray coming from under the hood.

### NOTICE

*Driving with the temperature gauge reading at the red mark can cause serious damage to your engine.*

CONTINUED

## If the Engine Overheats

---

### **WARNING**

Steam and spray from an overheated engine can seriously scald you.

Do not open the hood if steam is coming out.

1. Safely pull to the side of the road. Put the transmission in Neutral, and set the parking brake. Turn off the all accessories, and turn on the hazard warning indicators.
2. If you see steam and/or spray coming from under the hood, turn off the engine. Wait until you see no more signs of steam or spray, then open the hood.
3. If you do not see steam or spray, leave the engine running, and watch the temperature gauge. If the high heat is due to overloading, the engine should start to cool down almost immediately. If it does, wait until the temperature gauge comes down to the midpoint, then continue driving.
4. If the temperature gauge stays at the red mark, turn off the engine.
5. Look for any obvious coolant leaks, such as a split radiator hose. Everything is still extremely hot, so use caution. If you find a leak, it must be repaired before you continue driving (see **Emergency Towing** on page [179](#) ).
6. If you don't find an obvious leak, check the coolant level in the radiator reserve tank. Add coolant if the level is below the MIN mark (see **Adding Engine Coolant** on page [134](#) ).

7. If there was no coolant in the reserve tank, you may need to add coolant to the radiator. Let the engine cool down until the reading reaches the middle of the temperature gauge, or lower, before checking the radiator.

### **WARNING**

Removing the radiator cap while the engine is hot can cause the coolant to spray out, seriously scalding you.

Always let the engine and radiator cool down before removing the radiator cap.

8. Using gloves or a large heavy cloth, turn the radiator cap counterclockwise, without pushing down, to the first stop. After the pressure releases, push down on the cap, and turn it until it comes off.
9. Start the engine, and set the temperature control dial to maximum heat. Add coolant to the radiator up to the base of the filler neck. If you do not have the proper coolant mixture available, you can add plain water. Remember to have the cooling system drained and refilled with the proper mixture as soon as you can.
10. Put the radiator cap back on tightly. Run the engine, and watch the temperature gauge. If it goes back to the red mark, the engine needs repair (see **Emergency Towing** on page 179).
11. If the temperature stays normal, check the coolant level in the radiator reserve tank. If it has gone down, add coolant to the MAX mark. Put the cap back on tightly.

## Low Oil Pressure Indicator, Charging System Indicator

---

### Low Oil Pressure Indicator



This indicator should never come on when the engine is running. If it starts flashing or stays on, the oil pressure has dropped very low or lost pressure. Serious engine damage is possible and you should take immediate action.

#### NOTICE

*Running the engine with low oil pressure can cause serious mechanical damage almost immediately. Turn off the engine as soon as you can safely get the vehicle stopped.*

1. Safely pull off the road, and shut off the engine. Turn on the hazard warning indicators.
2. Let the vehicle sit for a minute. Open the hood, and check the oil level (see page 103). An engine very low on oil can lose pressure during cornering and other driving maneuvers.
3. If necessary, add oil to bring the level back to the full mark on the dipstick (see page 131).
4. Start the engine, and watch the oil pressure indicator. If it does not go out within 10 seconds, turn off the engine. There is a mechanical problem that needs to be repaired before you can continue driving (see **Emergency Towing** on page 179).

### Charging System Indicator



If the charging system indicator comes on brightly when the engine is running, the battery is not being charged.

Immediately turn off all electrical accessories. Try not to use other electrically operated controls such as the power windows. Keep the engine running; starting the engine will discharge the battery rapidly.

Go to a service station or garage where you can get technical assistance.



If this indicator comes on while driving, it means one of the engine's emissions control systems may have a problem. Even though you may feel no difference in your vehicle's performance, it can reduce your fuel economy and cause increased emissions. Continued operation may cause serious damage.

If you have recently refueled your vehicle, the indicator coming on could be due to a loose or missing fuel fill cap. Tighten the cap until it clicks at least three times. Tightening the cap will not turn the indicator off immediately; it takes at least three days of normal driving.

If the indicator comes on repeatedly, even though it may go off as you continue driving, have your vehicle checked by a dealer as soon as possible.

### NOTICE

*If you keep driving with the Malfunction Indicator Lamp on, you can damage your vehicle's emissions controls and the engine. Those repairs may not be covered by your vehicle's warranties.*

### Readiness Code

Your vehicle has certain "readiness codes" that are part of the on-board diagnostics for the emissions systems. In some states, part of the emissions testing is to make sure these codes are set. If they are not set, the test cannot be completed.

If your vehicle battery has been disconnected or gone dead, these codes are erased. It takes at least three days of driving under various conditions to set the codes again.

To check if they are set, turn the ignition to ON (II), without starting the engine. The malfunction indicator lamp will come on for 20 seconds. If it then goes off, the readiness codes are set. If it blinks five times, the readiness codes are not set. If possible, do not take your vehicle for a state emissions test until the readiness codes are set. Refer to **State Emissions Testing** for more information (see page 192 ).

## Brake System Indicator

---

**U.S.**

**BRAKE**

**Canada**



The brake system indicator normally comes on when you turn the ignition switch to ON (II), and as a reminder to check the parking brake. It will stay on if you do not fully release the parking brake.

If the brake system indicator comes on while driving, the brake fluid level is probably low. Press lightly on the brake pedal to see if it feels normal. If it does, check the brake fluid level the next time you stop at a service station (see page [139](#)).

If the fluid level is low, take your vehicle to a dealer, and have the brake system inspected for leaks or worn brake pads.

However, if the brake pedal does not feel normal, you should take immediate action. A problem in one part of the system's dual circuit design will still give you braking at two wheels. You will feel the brake pedal go down much farther before the vehicle begins to slow down, and you will have to press harder on the pedal.

Slow down by shifting to a lower gear, and pull to the side of the road when it is safe. Because of the long distance needed to stop, it is hazardous to drive the vehicle. You should have it towed and repaired as soon as possible (see **Emergency Towing** on page [179](#)).

If you must drive the vehicle a short distance in this condition, drive slowly and carefully.

If the electric motor will not close the convertible top, do the following.

1. Check the fuse for the convertible top motor (see page [174](#) ). If the fuse is blown, replace it with one of the same or lower rating.
2. Try closing the convertible top. If the new fuse blows immediately or the convertible top still does not operate, you can close it manually.

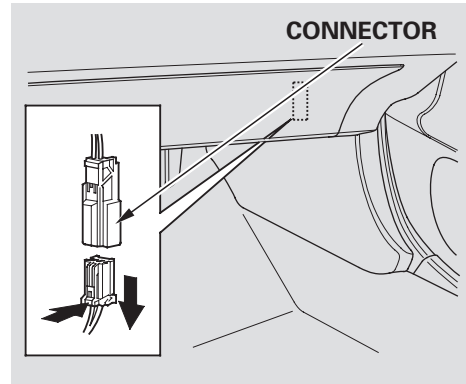

3. Locate the electrical connector for the convertible top motor. It is under the lower corner of the dashboard on the passenger's side. Disconnect the connector by pushing the tab and pulling the connector down.

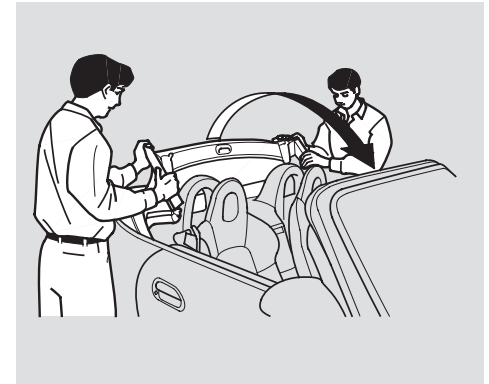

4. Holding each corner of the convertible top, raise the top and push it forward as far as it will go.
5. Follow steps 4 through 6 of the closing procedure on page [65](#) .

# Fuses

The vehicle's fuses are contained in three fuse boxes.

## INTERIOR

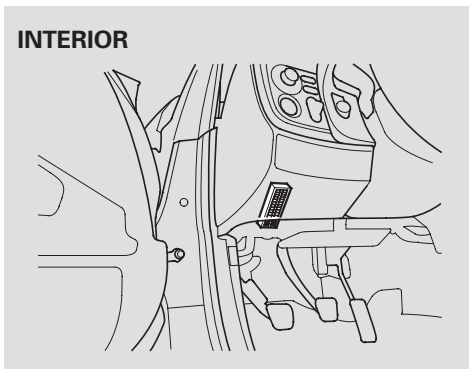

The interior fuse box is underneath the dashboard on the driver's side.

## UNDER-HOOD (PRIMARY)

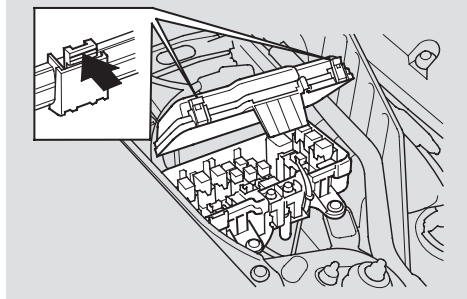

The primary under-hood fuse box is on the passenger's side next to the battery. To open it, push the two tabs as shown.

## UNDER-HOOD (AUXILIARY)

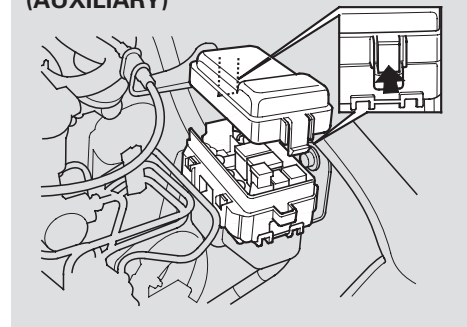

The auxiliary fuse box is on the driver's side, near the brake fluid reservoir. To open it, push the tab on each side, and remove the lid.



## Checking and Replacing Fuses

If something electrical in your vehicle stops working, check for a blown fuse first. Determine from the chart on pages 177 and 178, or the diagram on the fuse box lid, which fuse or fuses control that device. Check those fuses first, but check all the fuses before deciding that a blown fuse is the cause. Replace any blown fuses, and check if the device work.

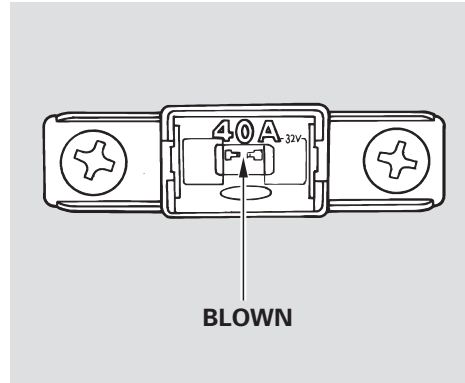

1. Turn the ignition switch to LOCK (0). Make sure the headlights and all other accessories are off.
2. Remove the cover from the fuse box.
3. Check each of the large fuses in the primary under-hood fuse box by looking through the top at the wire inside. Removing these fuses requires a Phillips-head screwdriver.
4. Check the smaller fuses in the under-hood fuse boxes and all the fuses in the interior fuse box by pulling out each one with the fuse puller provided in the primary under-hood fuse box.

CONTINUED

## Fuses

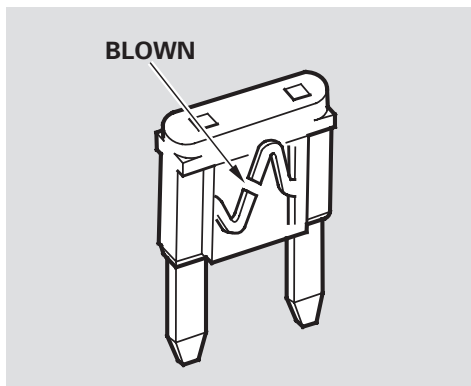

5. Look for a burned wire inside the fuse. If it is burned, replace it with one of the spare fuses of the same rating or lower.

If you cannot drive the vehicle without fixing the problem, and you do not have a spare fuse, take a fuse of the same rating or a lower rating from one of the other circuits. Make sure you can do without that circuit temporarily (such as the accessory power socket or radio).

If you replace the blown fuse with a spare fuse that has a lower rating, it might blow out again. This does not indicate anything wrong. Replace the fuse with one of the correct rating as soon as you can.

### NOTICE

*Replacing a fuse with one that has a higher rating greatly increases the chances of damaging the electrical system. If you do not have a replacement fuse with the proper rating for the circuit, install one with a lower rating.*

6. If the replacement fuse of the same rating blows in a short time, there is probably a serious electrical problem with your vehicle. Leave the blown fuse in that circuit, and have your vehicle checked by a qualified mechanic.

If the radio fuse is removed, the audio system will disable itself. The next time you turn on the radio you will see “Code” in the frequency display. Use the preset buttons to enter the five-digit code (see page 94 ).

# Fuse Locations

## INTERIOR FUSE BOX

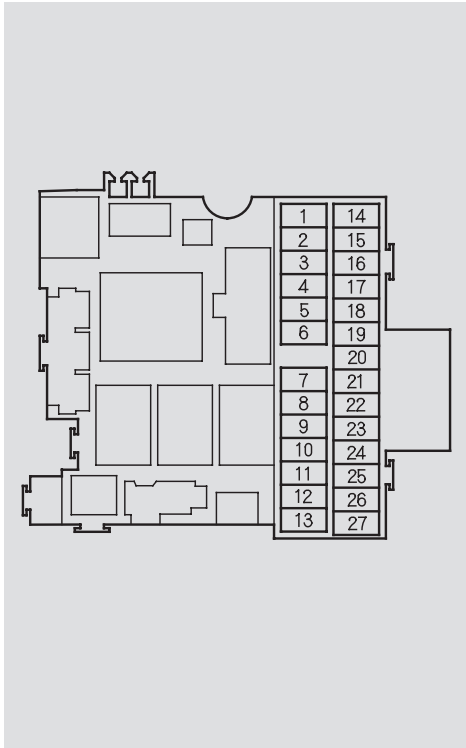

No.	Amps.	Circuits Protected
1	7.5 A	Windshield Wiper, Auto Stop Signal
2	15 A	Washer Motor
3	–	Not used
4	–	Not used
5	10 A	Accessory Socket
6	20 A	Windshield Wiper
7	7.5 A	Turn signal Light
8	15 A	ACG
9	7.5 A	Instrument Light, Backup Lights
10	15 A	Ignition Coil
11	7.5 A	Engine Start
12	15 A	Fuel Pump, SRS
13	10 A	SRS

\* : Canadian Model

No.	Amps.	Circuits Protected
14	10 A	Daytime Running Lights*
15	10 A	Keyless Entry
16	7.5 A	Back-up
17	7.5 A	Interior Light
18	10 A	Small Lights
19	15 A	Radio
20	7.5 A	Starter Signal
21	7.5 A	Heater Control, Cooling Fan Relay
22	7.5 A	Power Mirrors
23	20 A	Right Power Window
24	20 A	Left Power Window
25	–	Not used
26	–	Not used
27	–	Not used

CONTINUED

# Fuse Locations

## UNDER-HOOD FUSE BOXES (PRIMARY FUSE BOX)

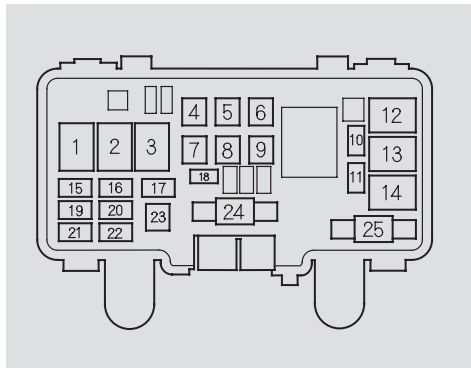

No.	Amps.	Circuits Protected
1	—	Lighting 1 Relay
2	—	Lighting 2 Relay
3	—	Horn Relay
4	40 A	Power Window Motor
5	20 A	Right Roof Motor
6	—	Not used
7	30 A	Backup ACC
8	20 A	Left Roof Motor
9	40 A	Heater Motor
10	20 A	Condenser Fan
11	—	Not used
12	—	Condenser Fan Relay
13	—	Cooling Fan Relay

No.	Amps.	Circuits Protected
14	—	Magnetic Clutch Relay
15	20 A	Right Headlight
16	15 A	ACG S
17	10 A	Hazard Warning Lights
18	20 A	Cooling Fan
19	—	Not used
20	15 A	Stop
21	20 A	Left Headlight
22	20 A	ABS F/S
23	30 A	ABS Motor
24	100 A	Battery
25	40 A	IG1 Main

## (AUXILIARY FUSE BOX)

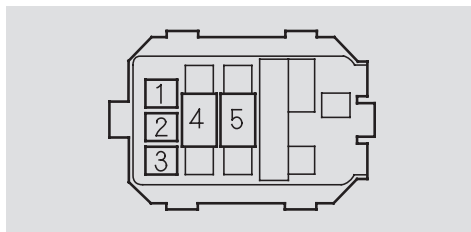

No.	Amps.	Circuits Protected
1	20 A	Rear Window Defogger
2	—	Not used
3	—	Not used
4	70 A	EPS
5	60 A	Air Pump

# Emergency Towing, If Your Vehicle Gets Stuck

## Emergency Towing

If your vehicle needs to be towed, call a professional towing service or organization. Never tow your vehicle with just a rope or chain. It is very dangerous.

**The only way you can safely tow your vehicle is with flat-bed equipment.** The operator will load your vehicle on the back of a truck. Any other method of towing will damage the drive system. When you contact the towing agency, inform them a flat-bed is required.

## If Your Vehicle Gets Stuck

If your vehicle gets stuck in sand, mud, or snow, call a towing service to pull it out (see the previous column).

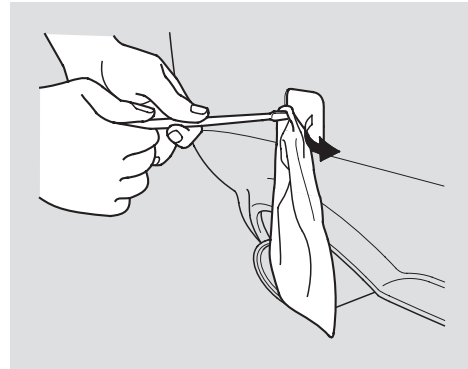

For very short distances, such as freeing the vehicle, you can use the detachable towing hook that mounts on the anchors in the front and rear bumpers.

To use the towing hook:

1. Remove the cover from the bumper.

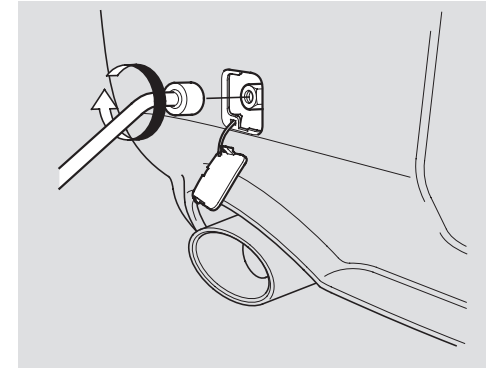

2. Remove the towing hook, hook extension, and wheel nut wrench from the tool box.
3. Using the wheel nut wrench, fasten the extension into the bolt hole in the anchor.

*CONTINUED*

## If Your Vehicle Gets Stuck

---

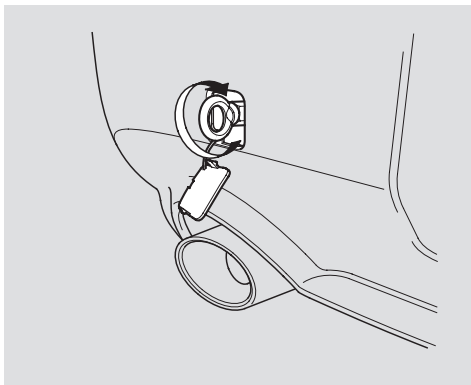

4. Screw the towing hook into the extension and tighten it securely by hand.

### **NOTICE**

*To avoid damage to your vehicle, use the towing hook for straight, flat ground towing only. Do not tow at an angle. The tow hook should not be used to tow the vehicle onto a flat bed. Do not use it as a tie down.*

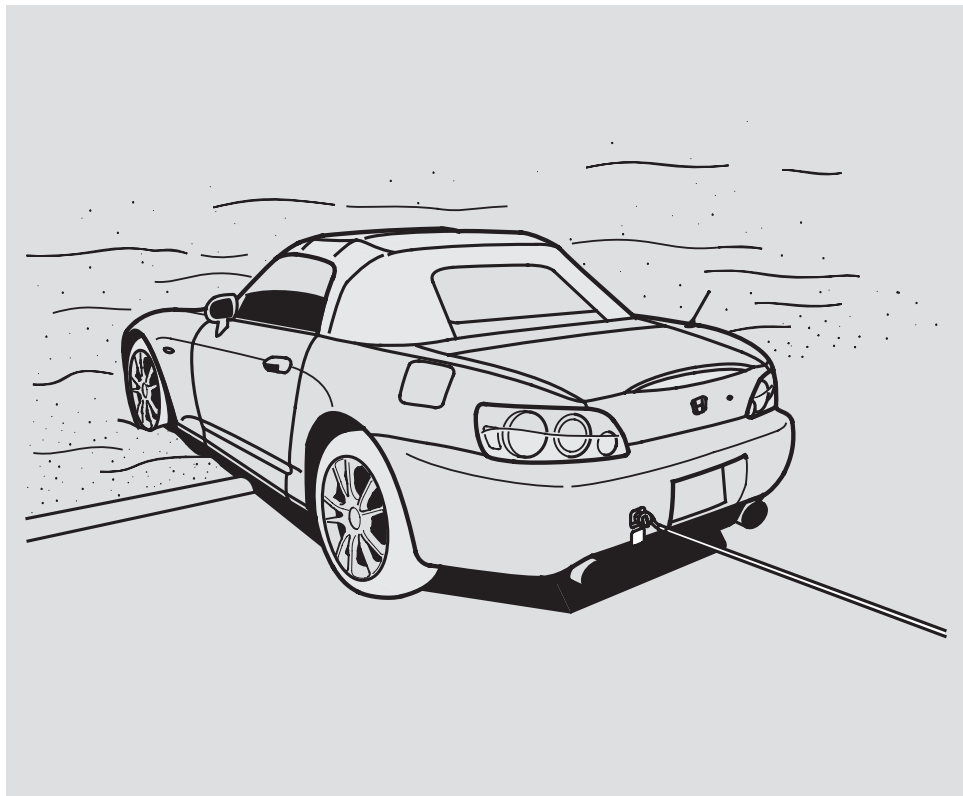

The diagrams in this section give you the dimensions and capacities of your vehicle, and the locations of the identification numbers. It also includes information you should know about your vehicle's tires and emissions control systems.

- Identification Numbers..... 182
- Specifications ..... 184
- DOT Tire Quality Grading  
    (U.S. Vehicles) ..... 186
- Uniform Tire Quality  
    Grading ..... 186
- Treadwear ..... 186
- Traction..... 186
- Temperature ..... 187
- Tire Labeling..... 188

- Emissions Controls..... 189
- The Clean Air Act..... 189
- Crankcase Emissions Control  
        System..... 189
- Evaporative Emissions Control  
        System..... 189
- Onboard Refueling Vapor  
        Recovery ..... 189
- Exhaust Emissions Controls ... 190
- PGM-FI System ..... 190
- Ignition Timing Control  
            System..... 190
- Secondary Air Injection  
            System..... 190
- Three Way Catalytic  
            Converter..... 190
- Replacement Parts..... 190
- Three Way Catalytic Converter... 191
- State Emissions Testing ..... 192

## Identification Numbers

---

Your vehicle has several identifying numbers located in various places.

The Vehicle Identification Number (VIN) is the 17-digit number your dealer uses to register your vehicle for warranty purposes. It is also necessary for licensing and insuring your vehicle. The easiest place to find the VIN is on a plate fastened to the top of the dashboard. You can see it by looking through the windshield on the driver's side. It is also on the Certification label attached to the driver's doorjamb, and is stamped on the engine compartment bulkhead. The VIN is also provided in bar code on the Certification label.

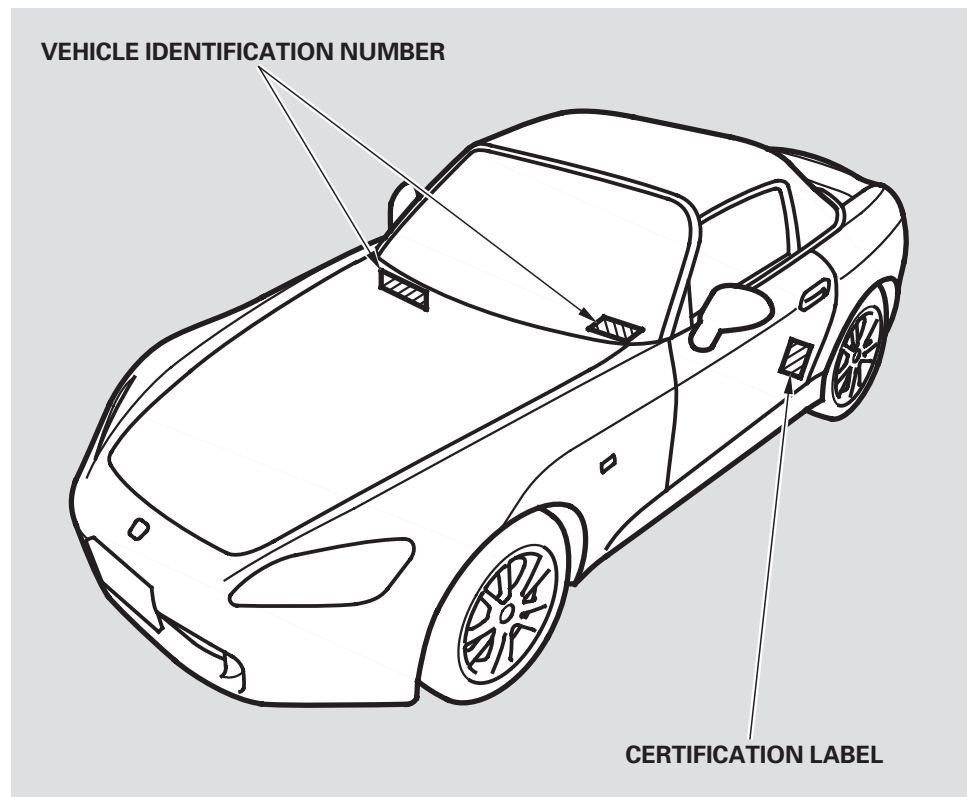



The Engine Number is stamped on the front right corner of the engine block, below the valve cover.

The Transmission Number is on a label underneath the transmission.

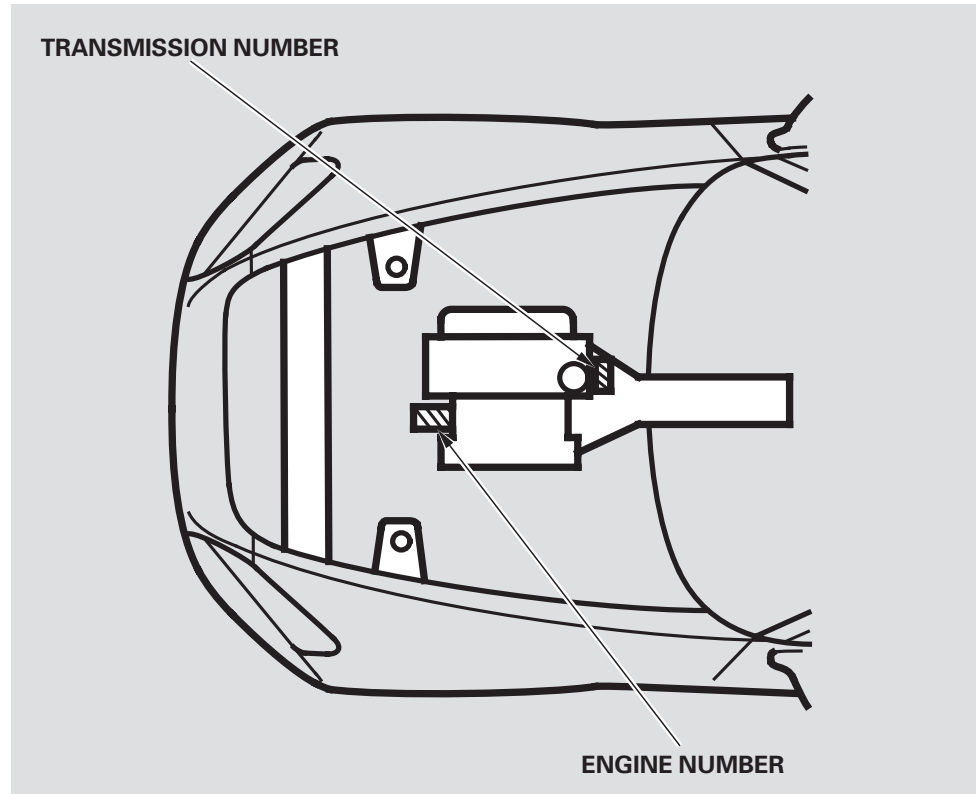

# Specifications

## Dimensions

Length		162.0 in (4,115 mm)
Width		68.9 in (1,750 mm)
Height		50.6 in (1,285 mm)
Wheelbase		94.5 in (2,400 mm)
Track	Front	57.9 in (1,470 mm)
	Rear	59.4 in (1,510 mm)

## Weights

Gross vehicle weight rating (GVWR)	See the certification label attached to the driver's doorjamb.
------------------------------------	--

## Engine

Type	Water cooled 4-stroke DOHC VTEC 4-cylinder gasoline engine
Bore x Stroke	3.43 x 3.57 in (87.0 x 90.7 mm)
Displacement	132 cu-in (2,157 cm <sup>3</sup> )
Compression ratio	11.1 : 1
Spark plugs	NGK : PFR7G-11S DENSO : PK22PR-L11S
Spark Plug Gap	0.04 in (1.1 mm) <small><sup>0</sup> 0 mm <sub>-0.1 mm</sub></small>

## Capacities

Fuel tank		13.2 US gal (50 ℓ)
Engine coolant	Change* <sup>1</sup>	1.72 US gal (6.5 ℓ)
	Total	2.01 US gal (7.6 ℓ)
Engine oil	Change* <sup>2</sup>	
	Including filter	5.1 US qt (4.8 ℓ)
	Without filter	5.1 US qt (4.8 ℓ)
Total	5.9 US qt (5.6 ℓ)	
Manual transmission fluid	Change	1.7 US qt (1.6 ℓ)
	Total	1.7 US qt (1.6 ℓ)
Differential fluid	Change	0.78 US qt (0.74 ℓ)
	Total	0.81 US qt (0.77 ℓ)
Windshield washer reservoir	U.S. Vehicles	2.6 US qt (2.5 ℓ)
	Canadian Vehicles	6.3 US qt (6.0 ℓ)

\* 1 : Including the coolant in the reserve tank and that remaining in the engine.

Reserve tank capacity:  
0.16 US gal (0.6 ℓ)

\* 2 : Excluding the oil remaining in the engine.

## Lights

Headlights	High	12 V – 55 W(H1)
	Low*	12 V – 35 W
Daytime running lights		
Front turn signal lights		
Rear turn signal lights		
Front side marker/ parking lights		
Back-up lights		
License plate light		
Interior light		
Trunk light		
Side turn signal lights		

\* : High voltage discharge type

## Air conditioning

Refrigerant type	HFC-134a (R-134a)
Charge quantity	19.4 – 21.2 oz (550 – 600 g)
Lubricant type	SP-10

## Battery

Capacity	12 V – 36 AH/5 HR
----------	-------------------

## Fuses

Under-hood	See page 178 or the fuse box cover.
Interior	See page 177 or the fuse label attached to the inside of the fuse box door under the dashboard.

## Alignment

Toe	Front	0.00 in (0.0 mm)
	Rear	in 0.15 in (3.7 mm)
Camber	Front	–0°30'
	Rear	–1°30'
Caster	Front	6°

## Tires

Size	Front	215/45R17 87W
	Rear	245/40R17 91W
	Spare Tire	T125/70D16 96M
Pressure	Front	32 psi (220 kPa , 2.2 kgf/cm <sup>2</sup> )
	Rear	32 psi (220 kPa , 2.2 kgf/cm <sup>2</sup> )
	Spare Tire	60 psi (420 kPa , 4.2 kgf/cm <sup>2</sup> )

## DOT Tire Quality Grading (U.S. Vehicles)

---

The tires on your vehicle meet all U.S. Federal Safety Requirements. All tires are also graded for treadwear, traction, and temperature performance according to Department of Transportation (DOT) standards. The following explains these gradings.

### **Uniform Tire Quality Grading**

Quality grades can be found where applicable on the tire sidewall between the tread shoulder and the maximum section width. For example:

**Treadwear 200**

**Traction AA**

**Temperature A**

All passenger car tires must conform to Federal Safety Requirements in addition to these grades.

### **Treadwear**

The treadwear grade is a comparative rating based on the wear rate of the tire when tested under controlled conditions on a specified government test course. For example, a tire graded 150 would wear one and one-half (1 1/2) times as well on the government course as a tire graded 100. The relative performance of tires depends upon the actual conditions of their use, however, and may depart significantly from the norm due to variations in driving habits, service practices, and differences in road characteristics and climate.

### **Traction – AA, A, B, C**

The traction grades, from highest to lowest, are AA, A, B, and C. Those grades represent the tire's ability to stop on wet pavement as measured under controlled conditions on specified government test surfaces of asphalt and concrete. A tire marked C may have poor traction performance.

**Warning:** The traction grade assigned to this tire is based on straight-ahead braking traction tests, and does not include acceleration, cornering, hydroplaning, or peak traction characteristics.

### **Temperature – A, B, C**

The temperature grades are A (the highest), B, and C, representing the tire's resistance to the generation of heat and its ability to dissipate heat when tested under controlled conditions on a specified indoor laboratory test wheel. Sustained high temperature can cause the material of the tire to degenerate and reduce tire life, and excessive temperature can lead to sudden tire failure. The grade C corresponds to a level of performance which all passenger car tires must meet under the Federal Motor Vehicle Safety Standard No. 109. Grades B and A represent higher levels of performance on the laboratory test wheel than the minimum required by law.

**Warning:** The temperature grade for this tire is established for a tire that is properly inflated and not overloaded. Excessive speed, underinflation, or excessive loading, either separately or in combination, can cause heat buildup and possible tire failure.

## Tire Labeling

---

The tires that came on your vehicle have a number of markings. Those you should be aware of are described below.

### ***Tire Size***

Whenever tires are replaced, they should be replaced with tires of the same size. The following is an example of tire size with an explanation of what each component means.

245/40R17 91W

- 245 — Tire width in millimeters.
- 40 — Aspect ratio (the tire's section height as a percentage of its width).
- R — Tire construction code (R indicates radial).
- 17 — Rim diameter in inches.

91 — Load index (a numerical code associated with the maximum load the tire can carry).

W — Speed symbol (an alphabetical code indicating the maximum speed rating).

### ***Tire Identification Number***

Tire Identification Number (TIN) is a group of numbers and letters that look like the following example TIN.

DOT B97R FW6X 2202

- DOT — This indicates that the tire meets all requirements of the U.S. Department of Transportation.
- B97R — Manufacturer's identification mark.
- FW6X — Tire type code.
- 2202 — Date of manufacture.

### ***Maximum Tire Pressure***

Max Press — The maximum air pressure the tire can hold.

### ***Maximum Tire Load***

Max Load — The maximum load the tire can carry at maximum air pressure.

The burning of gasoline in your vehicle's engine produces several by-products. Some of these are carbon monoxide (CO), oxides of nitrogen (NO<sub>x</sub>), and hydrocarbons (HC). Gasoline evaporating from the tank also produces hydrocarbons. Controlling the production of NO<sub>x</sub>, CO, and HC is important to the environment. Under certain conditions of sunlight and climate, NO<sub>x</sub> and HC react to form photochemical "smog." Carbon monoxide does not contribute to smog creation, but it is a poisonous gas.

## **The Clean Air Act**

The United States Clean Air Act\* sets standards for automobile emissions. It also requires that automobile manufacturers explain to owners how their emissions controls work and what to do to maintain them. This section summarizes how the emissions controls work. Scheduled maintenance is on page 125 .

\* In Canada, Honda vehicles comply with the Canadian emission requirements, as specified in an agreement with Environment Canada, at the time they are manufactured.

## **Crankcase Emissions Control System**

Your vehicle has a positive crankcase ventilation system. This keeps gasses that build up in the engine's crankcase from going into the atmosphere. The positive

crankcase ventilation valve routes them from the crankcase back to the intake manifold. They are then drawn into the engine and burned.

## **Evaporative Emissions Control System**

As gasoline evaporates in the fuel tank, an evaporative emissions control canister filled with charcoal adsorbs the vapor. It is stored in this canister while the engine is off. After the engine is started and warmed up, the vapor is drawn into the engine and burned during driving.

## **Onboard Refueling Vapor Recovery**

The onboard refueling vapor recovery (ORVR) system captures the fuel vapors during refueling. The vapors are adsorbed in a canister filled with activated carbon. While driving, the fuel vapors are drawn into the engine and burned off.

# Emissions Controls

---

## **Exhaust Emissions Controls**

The exhaust emissions controls include four systems: PGM-FI, ignition timing control, secondary air injection system, and three way catalytic converter. These four systems work together to control the engine's combustion and minimize the amount of HC, CO, and NO<sub>x</sub> that comes out the tailpipe. The exhaust emissions control systems are separate from the crankcase and evaporative emissions control systems.

### ***PGM-FI System***

The PGM-FI System uses sequential multiport fuel injection. It has three subsystems: air intake, engine control, and fuel control. The engine control module (ECM) uses various sensors to determine how much air is going into the engine. It then controls how much fuel to inject under all operating conditions.

### ***Ignition Timing Control System***

This system constantly adjusts the ignition timing, reducing the amount of HC, CO, and NO<sub>x</sub> produced.

### ***Secondary Air Injection System***

During engine warm-up, air is pumped into the exhaust to reduce emissions when the engine is cold.

### ***Three Way Catalytic Converter***

The three way catalytic converter is in the exhaust system. Through chemical reactions, it converts HC, CO, and NO<sub>x</sub> in the engine's exhaust to carbon dioxide (CO<sub>2</sub>), nitrogen (N<sub>2</sub>), and water vapor.

## **Replacement Parts**

The emissions control systems are designed and certified to work together in reducing emissions to levels that comply with the Clean Air Act. To make sure the emissions remain low, you should use only new Honda replacement parts or their equivalent for repairs. Using lower quality parts may increase the emissions from your vehicle.

The emissions control systems are covered by warranties separate from the rest of your vehicle. Read your warranty manual for more information.



## Three Way Catalytic Converter

The three way catalytic converter contains precious metals that serve as catalysts, promoting chemical reactions to convert the exhaust gasses without affecting the metals. The catalytic converter is referred to as a three-way catalyst, since it acts on HC, CO, and NOx. A replacement unit must be an original Honda part or its equivalent.

The three way catalytic converter must operate at a high temperature for the chemical reactions to take place. It can set on fire any combustible materials that come near it. Park your vehicle away from high grass, dry leaves, or other flammables.

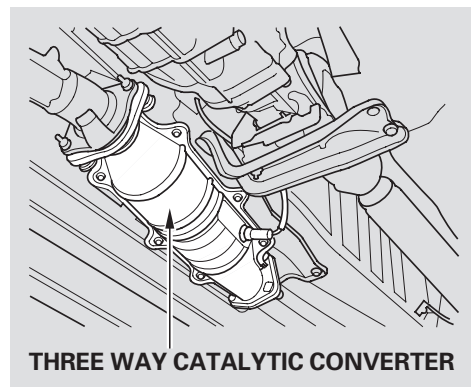

A defective three way catalytic converter contributes to air pollution, and can impair your engine's performance. Follow these guidelines to protect your vehicle's three way catalytic converter.

- Always use unleaded gasoline. Even a small amount of leaded gasoline can contaminate the catalyst metals, making the three way catalytic converter ineffective.

- Keep the engine tuned-up.
- Have your vehicle diagnosed and repaired if it is misfiring, back-firing, stalling, or otherwise not running properly.

# State Emissions Testing

---

## Testing of Readiness Codes

If you take your vehicle for a state emissions test shortly after the battery has been disconnected or gone dead, it may not pass the test. This is because of certain “readiness codes” that must be set in the on-board diagnostics for the emissions systems. These codes are erased when the battery is disconnected, and set again only after several days of driving under a variety of conditions.

If the testing facility determines that the readiness codes are not set, you will be requested to return at a later date to complete the test. If you must get the vehicle re-tested within the next two or three days, you can condition the vehicle for retesting by doing the following.

- Make sure the gas tank is nearly, but not completely, full (around 3/4).

- Make sure the vehicle has been parked with the engine off for 8 hours or more.
- Make sure the ambient temperature is between 20° and 95° F.
- Without touching the accelerator pedal, start the engine, and let it idle for 20 seconds.
- Keep the vehicle in Neutral. Increase the engine speed to 2,000 rpm, and hold it there until the temperature gauge rises to at least 1/4 of the scale (about 3 minutes).
- Select a nearby lightly traveled major highway where you can maintain a speed of 50 to 60 mph (80 to 97 km/h) for at least 20 minutes. Drive on the highway in 5th. Do not use the cruise control. When traffic allows, drive for 90 seconds without moving the

accelerator pedal. (Vehicle speed may vary slightly; this is okay.) If you cannot do this for a continuous 90 seconds because of traffic conditions, drive for at least 30 seconds, then repeat it two more times (for a total of 90 seconds).

- Then drive in city/suburban traffic for at least 10 minutes. When traffic conditions allow, let the vehicle coast for several seconds without using the accelerator pedal or the brake pedal.

If the testing facility determines the readiness codes are still not set, see your dealer.

# Warranty and Customer Relations

---

- Customer Service Information..... 194
- Warranty Coverages ..... 195
- Reporting Safety Defects (U.S. Vehicles) ..... 196
- Authorized Manuals ..... 197

## Customer Service Information

---

Honda dealership personnel are trained professionals. They should be able to answer all your questions. If you encounter a problem that your dealership does not solve to your satisfaction, please discuss it with the dealership's management. The service manager or general manager can help. Almost all problems are solved in this way.

If you are dissatisfied with the decision made by the dealership's management, contact your Honda Customer Service Office.

### U.S. Owners:

American Honda Motor Co., Inc.  
Automobile Customer Service  
Mail Stop 500-2N-7A  
1919 Torrance Boulevard  
Torrance, California 90501-2746

Tel: (800) 999-1009

### Canadian Owners: **CUSTOMER RELATIONS RELATIONS AVEC LA CLIENTÉLE**

Honda Canada Inc.  
715 Milner Avenue  
Toronto, ON  
M1B 2K8

Tel: 1-888-9-HONDA-9  
Fax: Toll-free 1-877-939-0909  
Toronto (416) 287-4776

### In Puerto Rico and the U.S. Virgin Islands:

Vortex Motor Corp.  
Bella International  
P.O. Box 190816  
San Juan, PR 00919-0816

Tel: (787) 250-4327

When you call or write, please give us this information:

- Vehicle Identification Number (see page [182](#) )
- Name and address of the dealer who services your vehicle
- Date of purchase
- Mileage on your vehicle
- Your name, address, and telephone number
- A detailed description of the problem
- Name of the dealer who sold the vehicle to you

### U.S. Owners

Your new vehicle is covered by these warranties:

***New Vehicle Limited Warranty*** — covers your new vehicle, except for the battery, emissions control systems, and accessories, against defects in materials and workmanship.

***Emissions Control Systems Defects Warranty and Emissions Performance Warranty*** — these two warranties cover your vehicle's emissions control systems. Time, mileage, and coverage are conditional. Please read your warranty manual for exact information.

***Original Equipment Battery Limited Warranty*** — this warranty gives up to 100 percent credit toward a replacement battery.

***Seat Belt Limited Warranty*** — a seat belt that fails to function properly is covered for the useful life of the vehicle.

***Rust Perforation Limited Warranty*** — all exterior body panels are covered for rust-through from the inside for the specified time period with no mileage limit.

***Accessory Limited Warranty*** — Honda Accessories are covered under this warranty. Time and mileage limits depend on the type of accessory and other factors. Please read your warranty manual for details.

***Replacement Parts Limited Warranty*** — covers all Honda replacement parts against defects in materials and workmanship.

***Replacement Battery Limited Warranty*** — provides prorated coverage for a replacement battery purchased from your dealer.

***Replacement Muffler Lifetime Limited Warranty*** — provides coverage for as long as the purchaser of the muffler owns the vehicle.

Restrictions and exclusions apply to all these warranties. Please read the 2005 Honda Warranty Information booklet that came with your vehicle for precise information on warranty coverages. Your vehicle's original tires are covered by their manufacturer. Tire warranty information is in a separate booklet.

### Canadian Owners

Please refer to the 2005 Warranty Manual that came with your vehicle.

## Reporting Safety Defects (U.S. Vehicles)

---

If you believe that your vehicle has a defect which could cause a crash or could cause injury or death, you should immediately inform the National Highway Traffic Safety Administration (NHTSA) in addition to notifying American Honda Motor Co., Inc.

If NHTSA receives similar complaints, it may open an investigation, and if it finds that a safety defect exists in a group of vehicles, it may order a recall and remedy campaign. However, NHTSA cannot become involved in individual problems between you, your dealer, or American Honda Motor Co., Inc.

To contact NHTSA, you may either call the Auto Safety Hotline toll-free at 1-800-424-9393 (or 366-0123 in Washington D.C. area) or write to: NHTSA, U.S. Department of Transportation, Washington, D.C. 20590. You can also obtain other information about motor vehicle safety from the Hotline.

## Purchasing Factory Authorized Manuals (U.S. only)

The publications shown below can be purchased from Helm Incorporated. You can order in any of three ways:

- Detach and mail the order form on the right half of this page
- Call Helm Inc. at 1-800-782-4356 (credit card orders only)
- Go online at [www.helminc.com](http://www.helminc.com)

If you are interested in other years or models, contact Helm Inc. at 1-800-782-4356.

Publication Form Number	From Description	Price Each*
61S2A05	2000-2005 Honda S2000 Service Manual	\$70.00
61S2A05EL	2000-2005 Honda S2000 Electrical Troubleshooting Manual	\$50.00
61S2A30	2000-2005 Honda S2000 Body Repair Manual	\$44.00
31S2A650	2005 Honda S2000 Owner's Manual	\$34.00
31S2AM00	2005 Honda S2000 Honda Service History	\$12.00
31S2AQ20	2005 Honda S2000 Quick Start Guide	\$12.00
HON-R	Order Form for Previous Years- Indicate Year and Model Desired	FREE
* Prices are subject to change without notice and without incurring obligation.		

*Valid only for sales within the United States. Canadian owners should contact their authorized Honda dealer.*

<b>ORDER TOLL FREE: 1-800-782-4356</b> <b>(NOTE: For Credit Card Holder Orders Only)</b> Monday-Friday 8:00 A.M. — 6:00 P.M. EST <b>MINIMUM CREDIT CARD PURCHASE \$10.00</b>
---

**OR**

By completing this form you can order the materials desired. You can pay by check or money order, or charge to your credit card. Mail to Helm Incorporated at the address shown on the back of the order form.

2005 HON	PUBLICATION NUMBER	VEHICLE MODEL		Qty	Price Each*	Total Price
		Name	Year			
* Prices are subject to change without notice and without incurring obligation.					TOTAL MATERIAL	
Orders are mailed within 10 days. Please allow adequate time for delivery.					Mich. Purchases Add 6% Sales Tax	
					HANDLING CHARGE	\$6.95
					GRAND TOTAL	

# Authorized Manuals

S H I P  T O	NOTE: Dealers and Companies please provide dealer or company name, and also the name of the person to whose attention the shipment should be sent. For purchases outside U.S.A. please write to the address shown below for a quotation.	
	Customer Name _____	Attention _____
	Street Address — No P.O. Box Number _____	Apartment Number _____
	City _____	State & Zip Code _____
	Daytime Telephone Number (     ) _____	

P A Y M E N T	<input type="checkbox"/> Check or money order enclosed payable to Helm Inc — U.S. funds only. Do not send cash					
	<input type="checkbox"/> Master Card <input type="checkbox"/> VISA <input type="checkbox"/> Check here if your billing address is different from the shipping address shown above.					
	Account Number _____     Expiration: Mo. Yr. _____					
	<table border="1" style="width: 100%; border-collapse: collapse;"><tr><td style="width: 25%; height: 20px;"> </td><td style="width: 25%; height: 20px;"> </td><td style="width: 25%; height: 20px;"> </td><td style="width: 25%; height: 20px;"> </td><td style="width: 25%; height: 20px;"> </td></tr></table>					
CUSTOMER SIGNATURE _____     DATE _____						

These Publications cannot be returned for credit without receiving advance authorization within 14 days of delivery. On returns, a restocking fee may be applied against the original order.

**HELM** P.O. BOX 07280-DETROIT, MICHIGAN 48207-1-800-782-4356

## Service Manual:

This manual covers maintenance and recommended procedures for repair to engine and chassis components. It is written for the journeyman mechanic, but is simple enough for most mechanically-inclined owners to understand.

## Electrical Troubleshooting Manual:

This manual complements the service manual by providing in-depth troubleshooting information for each electrical circuit in your vehicle.

## Body Repair Manual:

This manual describes the procedures involved in the replacement of damaged body parts.



**A**

Accessories..... 105

ACCESSORY (Ignition Key  
Position) ..... 53

Accessory Power Socket ..... 69

Additives, Engine Oil..... 132

Airbag (SRS) ..... 9, 19

Air Conditioning System..... 74  
Usage..... 76

Air Pressure, Tires ..... 150

Alcohol in Gasoline..... 100

Antifreeze ..... 134

Anti-lock Brakes (ABS)  
Indicator..... 41, 119  
Operation ..... 118

Anti-theft Steering Column Lock .. 53

Anti-theft System..... 94

Audio Panel..... 70

Audio System ..... 78

Automatic Seat Belt Tensioners.... 17

Automatic Speed Control..... 95

**B**

Back-up Light Replacement ..... 144

Battery  
Charging System  
Indicator..... 40, 170  
Jump Starting ..... 166  
Maintenance..... 154  
Specifications ..... 185

Before Driving ..... 99

Belts, Seat ..... 8, 16

Beverage Holder ..... 69

Booster Seats ..... 32

Brakes ..... 117  
Anti-lock System (ABS) ..... 118  
Break-in, New Linings ..... 100  
Fluid ..... 139  
Parking..... 67  
System Design ..... 118  
System Indicator..... 40, 172  
Wear Indicators ..... 118

Braking System..... 117

Break-in, New Vehicle ..... 100

Brightness Control, Instruments... 49

Brights, Headlights ..... 48

Bulb Replacement..... 140  
Back-up Lights ..... 144  
Headlights ..... 140  
Side Turn Signal Lights ..... 143

Specifications ..... 185

Turn Signal Lights..... 142, 144

Bulbs, Halogen..... 140

**C**

Capacities Chart..... 184

Carbon Monoxide Hazard ..... 35

Cargo, How to Carry ..... 107

CAUTION, Explanation of ..... ii

CD Care ..... 90

CD Changer..... 90

CD Changer Error Messages ..... 92

CD Error Messages..... 91

CD Player..... 88

Certification Label..... 182

Chains, Tires ..... 153

Changing a Flat Tire ..... 159

Changing Oil  
How to..... 132  
When to..... 125

Charging System Indicator .... 40, 170

Checklist, Before Driving..... 113

CONTINUED

# Index

---

Child Safety .....	23
Booster Seats .....	32
Child Seats.....	28
Important Safety Reminders .....	26
Larger Children .....	31
Risk with Airbags .....	24
Small Children.....	27
Child Seats.....	28
Cleaning Seat Belts.....	145
Clock.....	45
Clutch Fluid.....	139
CO in the Exhaust .....	189
Cold Weather, Starting in.....	114
Compact Spare Tire.....	158
Consumer Information * .....	194
Controls, Instruments and.....	37
Convertible Top .....	61
Convertible Top Cover.....	63
Lowering the Convertible Top..	61
Maintenance.....	65
Raising the Convertible Top .....	64
Coolant	
Adding.....	134
Checking.....	104
Proper Solution .....	134
Temperature Gauge.....	45

Crankcase Emission Control System.....	189
Cruise Control Indicator .....	41
Cruise Control Operation .....	95
Cup Holder .....	69
Customer Service Office .....	194

## D

DANGER, Explanation of.....	ii
Dashboard .....	3, 38
Daytime Running Lights.....	48
Daytime Running Lights Indicator.....	42
Dead Battery .....	166
Defects, Reporting Safety.....	196
Defogger, Rear Window.....	50
Defrosting the Windows.....	77
Differential Fluid .....	138
Dimensions.....	184
Dimming the Headlights .....	48
Dipstick	
Engine Oil.....	103
Directional Signals.....	48
Disc Brake Wear Indicators.....	118
Disposal of Used Oil.....	134

Do Not Tow a Trailer .....	119
Doors	
Locking and Unlocking.....	54
Monitor Indicator .....	41
Power Door Locks.....	54
DOT Tire Quality Grading .....	186
Downshifting, Manual Transmission.....	115
Driver and Passenger Safety.....	5
Driving .....	111
Economy .....	104
Driving Guidelines.....	112

## E

Economy, Fuel .....	104
Emergencies.....	157
Battery, Jump Starting .....	166
Brake System Indicator .....	172
Changing a Flat Tire .....	159
Charging System Indicator .....	170
Checking the Fuses.....	174
Closing the Convertible Top ....	173
Hazard Warning Flashers .....	49
Jump Starting .....	166
Low Oil Pressure Indicator .....	170

Malfunction Indicator Lamp .... 171  
 Overheated Engine ..... 167  
 Towing ..... 179  
 Emergency Brake ..... 67  
 Emergency Flashers ..... 49  
 Emergency Towing ..... 179  
 Emergency Trunk Opener ..... 55  
 Emissions Controls..... 189  
 Emissions Testing, State ..... 192  
 Engine  
   Adding Engine Coolant..... 134  
   Coolant Temperature Gauge .... 45  
   If It Won't Start ..... 164  
   Malfunction Indicator  
     Lamp ..... 41, 171  
   Oil Pressure Indicator..... 40, 170  
   Oil, What Kind to Use ..... 131  
   Overheating..... 167  
   Specifications ..... 184  
   Speed Limiter ..... 116  
   Start Button ..... 114  
   Starting..... 114  
 Ethanol in Gasoline ..... 100  
 Evaporative Emission Controls... 189  
 Exhaust Fumes ..... 35

Expectant Mothers, Use of Seat  
 Belts by ..... 14

**F**

Fan, Interior..... 75  
 Features ..... 73  
 Filling the Fuel Tank..... 101  
 Filters  
   Dust and Pollen..... 146  
   Oil ..... 132  
 Flashers, Hazard Warning..... 49  
 Flat Tire, Changing a ..... 159  
 Fluids  
   Brake ..... 139  
   Clutch ..... 139  
   Manual Transmission ..... 137  
   Windshield Washer ..... 136  
 FM Stereo Radio Reception ..... 81  
 Four-way Flashers ..... 49  
 Fuel..... 100  
   Fill Door and Cap..... 101  
   Gauge ..... 45  
   Low Fuel Indicator ..... 42  
   Octane Requirement ..... 100  
   Oxygenated ..... 100

Tank, Refueling ..... 101  
 Fuel Economy ..... 104  
 Fuel Station Procedures ..... 101  
 Fuses, Checking the..... 174

**G**

Gas Mileage, Improving..... 104  
 Gasohol ..... 100  
 Gasoline ..... 100  
   Gauge ..... 45  
   Low Fuel Indicator ..... 42  
   Octane Requirement ..... 100  
   Tank, Refueling ..... 101  
 Gauges ..... 44  
   Engine Coolant Temperature .... 45  
   Fuel..... 45  
 Gearshift Lever Positions  
   Manual Transmission ..... 116  
 Gross Vehicle Weight Rating  
   (GVWR) ..... 108, 184

CONTINUED

# Index

---

## H

Halogen Headlight Bulbs.....	140
Hazard Warning Flashers.....	49
Headlights	
Aiming.....	140
Daytime Running Lights.....	48
High Beam Indicator.....	42
Reminder Tone.....	48
Replacing Halogen Bulbs.....	140
Turning on.....	48
Heating and Cooling System.....	74
High Beam Lever.....	48
Hood, Opening the.....	102
Horn.....	46
Hydraulic Clutch.....	139

## I

Identification Number, Vehicle.....	182
Ignition	
Keys.....	51
Switch.....	53
Timing Control System.....	190
Immobilizer System.....	52

Important Safety Precautions.....	6
Indicators	
ABS (Anti-Lock Brake).....	41
Brake (Parking and Brake System).....	40, 172
Charging System.....	40, 170
Cruise Control.....	41
Door-open.....	41
DRL (Daytime Running Lights).....	42
EPS (Electrical Power Steering).....	41
High Beam.....	42
Key (Immobilizer System).....	42
Low Fuel.....	42
Low Oil Pressure.....	40, 170
Maintenance Required.....	43
Malfunction Indicator Lamp.....	41, 171
Seat Belt.....	40
SRS.....	41
Trunk-open.....	41
Turn Signal and Hazard Warning.....	42
Indicators, Instrument Panel.....	40

Inflation, Proper Tire.....	149
Recommended Pressures.....	150
Inside Mirror.....	66
Inspection, Tire.....	150
Installing a Child Seat.....	28
Instrument Panel.....	39
Instrument Panel Brightness.....	49
Interiors.....	40
Introduction.....	i

## J

Jacking Up the Vehicle.....	160
Jack, Tire.....	159
Jump Starting.....	166

## K

Keys.....	51
-----------	----

## L

Label, Certification.....	182
Lane Change, Signaling.....	48
Lap/Shoulder Belts.....	12, 16

Lights  
 Bulb Replacement ..... 140  
 Indicator..... 40  
 Turn Signal..... 48  
 Load Limits..... 108  
 LOCK (Ignition Key Position) ..... 53  
 Locks  
 Anti-theft Steering Column ..... 53  
 Fuel Fill Door ..... 101  
 Power Door ..... 54  
 Trunk ..... 54  
 Low Coolant Level..... 104  
 Low Fuel Indicator ..... 42  
 Low Oil Pressure Indicator ... 40, 170  
 Lubricant Specifications Chart ... 184  
 Luggage, Storing (Cargo) ..... 107

**M**

Maintenance..... 121  
 Owner's Maintenance  
 Checks ..... 124  
 Record..... 127  
 Required Indicator..... 43  
 Safety..... 122  
 Schedule ..... 123

Malfunction Indicator Lamp .. 41, 171  
 Manual Transmission..... 115  
 Manual Transmission Fluid ..... 137  
 Meters, Gauges..... 44  
 Methanol in Gasoline ..... 100  
 Mirrors, Adjusting ..... 66  
 Modifying Your Vehicle..... 106

**N**

New Vehicle Break-in ..... 100  
 Normal Shift Speeds..... 116  
 NOTICE, Explanation of..... i  
 Numbers, Identification..... 182

**O**

Octane Requirement, Gasoline.... 100  
 Odometer..... 44  
 Odometer, Trip ..... 44  
 Oil  
 Change, How to ..... 132  
 Change, When to ..... 125  
 Checking Engine ..... 103  
 Pressure Indicator ..... 40, 170

Selecting Proper Viscosity  
 Chart ..... 132  
 ON (Ignition Key Position) ..... 53  
 Onboard Refueling Vapor  
 Recovery ..... 189  
 Opening the Trunk..... 54  
 Outside Mirrors ..... 66  
 Overheating, Engine ..... 167  
 Owner's Maintenance Checks ..... 124  
 Oxygenated Fuels..... 100

**P**

Panel Brightness Control ..... 49  
 Parking..... 117  
 Parking Brake ..... 67  
 Parking Brake and Brake System  
 Indicator..... 172  
 Parking Lights..... 48  
 PGM-FI System..... 190  
 Pollen Filter ..... 146  
 Power Door Locks..... 54  
 Power Socket Location ..... 68  
 Power Windows ..... 59

CONTINUED

# Index

---

Pregnancy, Using Seat Belts .....	14
Preparing to Drive .....	113
Protecting Adults and Teens.....	10
Additional Safety Precautions....	15
Advice for Pregnant Women.....	14
Protecting Children .....	23
General Guidelines.....	23
Protecting Larger Children .....	31
Protecting Small Children .....	27

## R

Radiator Overheating.....	167
Radio/CD Sound System.....	78
Radio Theft Protection.....	94
Readiness Codes.....	171, 192
Rear Lights, Bulb Replacement..	144
Rear View Mirror.....	66
Rear Window Defogger .....	50
Reclining the Seat-backs.....	58
Recommended Shift Speeds .....	116
Recovery Vehicle, Emergency	
Towing .....	179
Refueling.....	101
Reminder Indicators.....	39, 40
Remote Transmitter.....	56

Replacement Information	
Dust and Pollen Filter .....	146
Engine Oil and Filter .....	132
Fuses .....	174
Light Bulbs.....	140
Schedule .....	123
Tires .....	152
Wiper Blades.....	147
Replacing Seat Belts After a	
Crash.....	17
Reporting Safety Defects* .....	196
Reserve Tank, Engine	
Coolant.....	104, 134
Restraint, Child .....	23
Reverse Lockout.....	116
Rotation, Tire .....	151

## S

Safety Belts.....	8, 16
Safety Defects, Reporting* .....	196
Safety Features .....	7
Airbags.....	9
Seat Belts .....	8
Safety Labels, Location of .....	36
Safety Messages .....	ii

Satellite Radio.....	83
Seat Belts .....	8, 16
Additional Information.....	16
Advice for Pregnant Women.....	14
Automatic Seat Belt	
Tensioners.....	17
Cleaning .....	145
Lap/Shoulder Belt.....	16
Maintenance.....	17
Reminder Indicator and	
Beeper.....	16, 40
System Components.....	16
Use During Pregnancy.....	14
Seats, Adjusting the.....	58
Serial Number .....	182
Service Intervals .....	125
Service Manual* .....	197
Service Station Procedures .....	101
Setting the Clock .....	45
Shifting	
Manual Transmission .....	115
Side Turn Signal, Bulb	
Replacement .....	143
Signaling Turns.....	48
Snow Tires.....	153
Sound System.....	78

Spare Tire	
Inflating.....	150
Specifications .....	185
Spark Plugs.....	184
Specifications .....	184
Speed Control.....	95
Speed Limiter.....	116
SRS, Additional Information.....	19
Additional Safety Precautions....	22
Airbag Service.....	21
Airbag System Components.....	19
How the SRS Indicator Works.....	21
How Your Front Airbags Work.....	19
SRS Indicator.....	21, 41
Start Button .....	114
Starting the Engine.....	114
In Cold Weather at High Altitude .....	114
With a Dead Battery .....	166
State Emissions Testing .....	192
Steam Coming from Engine.....	167
Steering Wheel	
Anti-theft Column Lock .....	53
Stereo Sound System .....	78

Storing Your Vehicle.....	155
Stuck Vehicle .....	179
Supplemental Restraint System	
Servicing .....	21
SRS Indicator.....	21, 41
System Components.....	19
Synthetic Oil.....	132

## T

Taillights, Changing Bulbs.....	144
Taking Care of the Unexpected ..	157
Technical Descriptions	
DOT Tire Quality Grading* .....	186
Emissions Control Systems.....	189
Three Way Catalytic Converter.....	191
Temperature Gauge .....	45
Tensioners, Seat Belts .....	17
Theft Protection, Radio.....	94
Three Way Catalytic Converter..	191
Time, Setting the .....	45
Tire Chains.....	153
Tire, How to Change a Flat .....	159
Tire Labeling.....	188

Tires .....	148
Air Pressure .....	150
Balancing .....	151
Chains .....	153
Checking Wear .....	150
Compact Spare Tire .....	158
DOT Tire Quality Grading.....	186
Inflation.....	149
Inspection .....	150
Replacing .....	152
Rotating.....	151
Snow.....	153
Specifications .....	185
Wear .....	151
Tools, Tire Changing .....	159
Towing	
A Trailer, Do Not.....	119
Emergency Wrecker .....	179
Trailer, Do Not Tow a .....	119
Transmission	
Checking Fluid Level, Manual Transmission.....	137
Fluid Selection.....	137
Identification Number.....	183

CONTINUED

# Index

---

Shifting the Manual Transmission.....	115
Treadwear .....	186
Trip Meter .....	44
Trunk.....	54
Emergency Trunk Opener .....	55
Opening the.....	54
Open Monitor Indicator .....	41
Turn Signals .....	48

## U

Unexpected, Taking Care of the .....	157
Uniform Tire Quality Grading .....	186
Unleaded Gasoline.....	100
Used Oil, How to Dispose of .....	134

## V

Vehicle Capacity Load .....	108
Vehicle Dimensions.....	184
Vehicle Identification Number.....	182
Vehicle Storage.....	155
Ventilation.....	76
VIN .....	182

Viscosity, Oil.....	132
---------------------	-----

## W

WARNING, Explanation of .....	ii
Warning Labels, Location of .....	36
Warranty Coverages* .....	195
Washer, Windshield	
Checking the Fluid Level .....	136
Operation .....	47
Wheels .....	152
Alignment and Balance.....	151
Wrench, Nut.....	160
Windows, Operating the Power.....	59
Windshield	
Cleaning .....	47
Defroster .....	77
Washers .....	47
Wipers, Windshield	
Changing Blades.....	147
Operation .....	47
Worn Tires .....	151
Wrecker, Emergency Towing.....	179

## X

XM Satellite Radio .....	83
--------------------------	----

\*: U.S.



## Service Information Summary

---

**Gasoline:**

Premium unleaded gasoline, pump octane number of 91 or higher.

**Fuel Tank Capacity:**

13.2 US gal (50 ℓ)

**Recommended Engine Oil:**

API premium grade 10W-30 detergent oil (see page [131](#)).

Oil change capacity (including filter):

5.1 US qt (4.8 ℓ)

**Manual Transmission Fluid:**

Honda Manual Transmission Fluid preferred, or an SAE 10W-30 or 10W-40 motor oil as a temporary replacement (see page [137](#)).

Capacity:

1.7 US qt (1.6 ℓ)

**Brake Fluid:**

Honda Heavy Duty Brake Fluid DOT 3 preferred, or a DOT 3 or DOT 4 brake fluid as a temporary replacement (see page [139](#)).

**Tire Pressure (measured cold):**

Front:

32 psi (220 kPa , 2.2 kgf/cm<sup>2</sup>)

Rear:

32 psi (220 kPa , 2.2 kgf/cm<sup>2</sup>)

**Spare Tire Pressure:**

Front:

60 psi (420 kPa , 4.2 kgf/cm<sup>2</sup>)